

Table of Contents

Acknowledgements.....	i
Declarations	ii
Summary	v

CHAPTER 1: ORIENTATION, PROBLEM FORMULATION AND AIMS OF THE STUDY		Page
1.1	INTRODUCTION	2
1.2	BACKGROUND TO THE STUDY	4
1.2.1	Leadership	4
1.2.2	The nature of distributed leadership	6
1.3	THE STUDY PROBLEM	12
1.4	AIMS AND THE OBJECTIVE TO THE STUDY	14
1.5	STUDY METHODOLOGY	15
1.5.1	Study approach	15
1.5.2	Study population and sample	15
1.5.3	Instrumentation and data collection technique	18
1.5.4	Data analysis and interpretation	19
1.6	RELIABILITY AND VALIDITY OF THE STUDY	21
1.7	PLANNING OF THE STUDY	23
1.8	DEFINITIONS OF THE MAIN CONCEPTS	24
1.8.1	Distributed leadership	24
1.8.2	Leadership strategies	24
1.8.3	Effective schools	25
1.9	CONCLUSION	26

CHAPTER 2: THEORETICAL FRAMEWORK OF THE THEORIES AND PRACTICES OF DISTRIBUTED LEADERSHIP AS STRATEGY IN SCHOOLS		27
2.1	INTRODUCTION	27
2.2	THE CONCEPT OF SCHOOL LEADERSHIP	28
2.2.1	Introduction	28
2.2.2	What is school leadership?	28
2.2.3	The concept of school leadership in South Africa	31
2.2.4	Conclusion	33
2.3	THE THEORIES OF TRADITIONAL SCHOOL LEADERSHIP	33
2.4	SCHOOL LEADERSHIP THEORY TO PRACTICE WITH ACTION STUDY	36
2.5	DISTRIBUTED LEADERSHIP IN SCHOOLS	38
2.5.1	Introduction	38
2.5.2	Distributed leadership and democratic leadership	40
2.5.3	Distributed leadership and teacher leadership	42
2.5.4	Distributed leadership and servant leadership	43
2.5.5	Distributed leadership and collaborative leadership	45
2.5.6	Distributed leadership and shared leadership	47
2.5.7	Distributed leadership and delegated leadership	49
2.6	PREVIOUS STUDY FINDINGS ON DISTRIBUTED LEADERSHIP	50
2.7	THE ROLE OF DISTRIBUTED LEADERSHIP AS STRATEGY TO CHANGE LEADERSHIP THROUGH COACHING	55
2.8	THE ROLE OF DISTRIBUTED LEADERSHIP AS STRATEGY TO CHANGE LEADERSHIP THROUGH MENTORING	57
2.9	CONCLUSION	58

CHAPTER 3: COACHING AS DISTRIBUTIVE LEADERSHIP STRATEGY, ASSURING EFFECTIVE SCHOOLS		60
3.1	INTRODUCTION	60
3.2	THE COLLABORATIVE NATURE OF COACHING AS A SEVEN-STAGE PATTERN THAT LINKS TO DISTRIBUTED LEADERSHIP STRATEGY	62
3.3	MODELS OF COACHING AS DISTRIBUTIVE LEADERSHIP STRATEGY	65
3.4	COACHING IN EDUCATIONAL SETTINGS	66
3.4.1	The GROW coaching model as distributed leadership strategy	67
3.4.2	The STRIDE coaching model as distributed leadership strategy	68
3.4.3	The OSCAR coaching model as distributed leadership strategy	69
3.4.4	The strategic executive coaching model as distributive leadership strategy	71
3.4.5	The team coaching model as distributive leadership strategy	73
3.5	THE ROLE OF COACHES TO DISTRIBUTED LEADERSHIP THROUGH COACHING TO ASSURE EFFECTIVE SCHOOLS	75
3.5.1	The role of coaches to distribute leadership by means of the GROW coaching model	75
3.5.2	The role of coaches to distribute leadership by means of the STRIDE coaching model	76
3.5.3	The role of coaches to distribute leadership by means of the OSCAR coaching model	77
3.5.4	The role of coaches to distribute leadership by means of the strategic executive coaching model	77
3.5.5	The role of coaches to distribute leadership by means of the team coaching model	78
3.6	THE IMPLEMENTATION OF THE OSCAR COACHING MODEL AS LEADERSHIP STRATEGY TO ASSURE MORE EFFECTIVE MEETINGS IN SOUTH AFRICAN SCHOOLS	79
3.7	PREVIOUS STUDY FINDINGS ON COACHING AS PART OF DISTRIBUTIVE LEADERSHIP STRATEGY	80
3.8	THE INFLUENCE OF INTERNAL COACHING TO ENHANCE THE DISTRIBUTION OF LEADERSHIP	83
3.9	CONCLUSION	84

CHAPTER 4: STUDY METHODOLOGIES		86
4.1	INTRODUCTION	86
4.2	RESEARCH DESIGN	86
4.2.1	Introduction	86
4.2.2	Rationale for choosing the qualitative research design	86
4.2.3	Additional research designs	88
4.3	THE RESEARCH PROBLEM	91
4.4	AIMS OF THE RESEARCH	92
4.5	POPULATION AND SAMPLING	93
4.6	ETHICAL MEASURES	94
4.6.1	Competency of the researcher	94
4.6.2	Relationships with participants	94
4.6.3	Protection of human rights	95
4.6.4	Informed consent	95
4.6.5	Fair treatment	96
4.6.6	Privacy	97
4.6.7	Confidentiality and anonymity	97
4.6.8	Procedures that were followed	98
4.7	TRUSTWORTHINESS, RELIABILITY AND VALIDITY OF THE RESEARCH	98
4.8	INSTRUMENTATION	102
4.9	FIELDWORK AND THE DATA COLLECTION PROCEDURES	103
4.9.1	Literature control	103
4.9.2	Interviews	104
4.9.2.1	<i>The interview protocol</i>	105
4.9.2.2	<i>The interview schedule</i>	106
4.9.3	Document analysis	108
4.10	ANALYSIS AND INTERPRETATION OF DATA	108
4.10.1	Analysis of data	108
4.10.2	Interpretation of data	109
4.11	CONCLUSION	110

CHAPTER 5: DATA PRESENTATION, ANALYSIS AND INTERPRETATION		112
5.1	INTRODUCTION	112
5.2	DATA INTERPRETATION	113
5.3	DATA ANALYSIS	114
5.4	DISCUSSIONS OF THE THEMES	116
5.4.1	Theme 1: Distributed leadership is about teacher leadership	116
5.4.2	Theme 2: Distributed leadership is about teamwork	121
5.4.3	Theme 3: Distributed leadership is about democracy and sharing of leadership at all levels	127
5.4.4	Theme 4: Distributed leadership is about interaction between all leaders	133
5.4.5	Theme 5: Distribution of leadership is about sharing of leadership and not the delegation of leadership	142
5.4.6	Theme 6: Distributed leadership is about ensuring effective schools in South Africa	150
5.4.7	Theme 7: Distributed leadership is about the development of coaches as a distributed leadership strategy	164
5.4.8	Theme 8: Distributed leadership is about the OSCAR coaching model to facilitate meetings as distributed leadership strategy to ensure effective schools	166
5.5	CONCLUSION	175

CHAPTER 6: SUMMARY, FINDINGS AND RECOMMENDATIONS		177
6.1	INTRODUCTION	178
6.2	SUMMARY OF RESEARCH	177
6.3	LIMITATIONS	178
6.4	IMPORTANT FINDINGS ABOUT THE ROLE OF DISTRIBUTED LEADERSHIP TO ENSURE EFFECTIVE SCHOOLS IN SOUTH AFRICA	182
6.4.1	Findings with respect to teacher leadership	182
6.4.2	Findings with respect to teamwork	182
6.4.3	Findings with respect to democracy and sharing of leadership	183
6.4.4	Findings with respect to the interaction between all leaders	184
6.4.5	Findings with respect to sharing of leadership and delegation of leadership	185
6.4.6	Findings with respect to ensuring effective schools	185
6.4.7	Findings with respect to the development of coaches as a distributed leadership strategy	186
6.4.8	Findings with respect to the OSCAR coaching model to facilitate meetings as a distributed leadership strategy to ensure effective schools	187
6.4.8.1	<i>Conceptualise how the OSCAR coaching model as a distributed leadership strategy is developed, implemented and the impact thereof</i>	187
6.4.8.2	<i>Conceptualise the purpose and the benefit of using the OSCAR coaching model to facilitate meetings as a distributed leadership strategy</i>	188
6.5	Recommendations	189
6.5.1	Recommendation with respect to teacher leadership	189
6.5.2	Recommendation with respect to teamwork	189
6.5.3	Recommendation with respect to democracy and sharing of leadership	190
6.5.4	Recommendation with respect to the interaction between all leaders	190
6.5.5	Recommendation with respect to sharing of leadership and delegation of leadership	191
6.5.6	Recommendation with respect to ensuring effective schools	191
6.5.7	Recommendation with respect to the development of coaches as a distributed leadership strategy	191
6.5.8	Recommendation with respect to the OSCAR coaching model to facilitate meetings as a distributed leadership strategy to ensure effective schools	192
6.6	Recommendations for further research	193
6.7	Contribution of the study towards the theory and practice of education management as a discipline	194
6.8	Conclusions	195

7: REFERENCE LIST	196
--------------------------	-----

LIST OF APPENDIXES		219
A	PERMISSION TO CONDUCT RESEARCH BY DEPARTMENT OF EDUCATION	219
B	ETHICAL CLEARNESS TO CONDUCT RESEARCH	222
C	CONSENT TO PARTICIPATE IN RESEARCH	224
D	INTERVIEW SCHEDULE	228
E	TRANSCRIPTION AND TYPING SERVICES	231
F	NON PARTICIPATION OF DYSFUNCTIONAL SCHOOLS	233
G	TRAINING MANUAL	235
H	FEEDBACK ON OSCAR COACHING MODEL TO FACILITATE MEETINGS	244

LIST OF TABLES		Page
2.1	The human conduct of school leaders	30
2.2	Six-step study cycle	36
2.3	Critical key behaviour of leaders to be effective followers	44
2.4	Indicators for leaders to be good followers	45
2.5	Levels of collaborative leadership	47
3.1	The seven Cs of coaching	64
3.2	Effective coaching	66
3.3	The GROW model of coaching	67
3.4	The STRIDE model of coaching	68
3.5	The OSCAR coaching model	70
3.6	The strategic executive coaching model	72
3.7	The GROW coaching model to distribute leadership	75
3.8	The STRIDE coaching model to distribute leadership	76
3.9	The OSCAR coaching model to distribute leadership	77
3.10	The role of coaches to distribute leadership by means of the strategic executive coaching model	77
3.11	The team coaching model to distribute leadership	78
3.12	Internal coaching and distributed leadership	84
5.1	Summary of themes and sub-themes derived from the data	115
5.2	Types of distribution within effective schools	126
5.3	Distributed leadership is about democracy and sharing of leadership	129
5.4	Distributed leadership is about	130
5.5	Distributed leadership is about	131
5.6	Distributed leadership is about	132
5.7	Distributed leadership is about democracy and sharing of leadership	132
5.8	Sharing versus delegation	142

5.9	Sharing versus delegation	144
5.10	Sharing versus delegation	145
5.11	Sharing versus delegation	147
5.12	Sharing versus delegation	148
5.13	The effectiveness of distributed leadership at South African schools	152
5.14	The role of distributed leadership to ensure effective schools in South Africa	153
5.15	The effectiveness of distributed leadership at South African schools	154
5.16	The effectiveness of distributed leadership at South African schools	155
5.17	The effectiveness of distributed leadership at South African schools	156
5.18	The effectiveness of distributed leadership at South African schools	157
5.19	The effectiveness of distributed leadership at South African schools	159
5.20	The role of distributed leadership to ensure effective schools in South Africa	160
5.21	Leaders at not sure if distributed leadership will contribute to the effectiveness of schools in South Africa	160
5.22	Uncertainty with some leaders	161
5.23a	The acceptance of distributed leadership as a leadership strategy at South African schools	162
5.23b	The acceptance of distributed leadership as a leadership strategy at South African schools	162
5.24	Elaborates on the acceptance of the distribution of leadership at South African schools	163
5.25	Formal training as a coach	165

LIST OF BAR CHARTS		Page
1	Delegation of leadership	143
2	Sharing versus delegation	144
3	Sharing versus delegation	146
4	Sharing versus delegation	147
5	Sharing versus delegation	148
6	Overall comparative analysis sharing versus delegation	149

LIST OF PIE CHARTS		Page
1	Distributed leadership is about democracy and sharing of leadership	128
2	Distributed leadership is about democracy and sharing of leadership	129
3	Distributed leadership is about democracy and sharing of leadership	130
4	Distributed leadership is about democracy and sharing of leadership	131
5	Distributed leadership is about democracy and sharing of leadership	132
6	Comparative view of distributed leadership	133
7	Division amongst leaders	153
8	Distributed leadership can have a positive impact on schools in South Africa	155
9	Distributed leadership is about ensuring effective schools in South Africa	157
10	Distributed leadership is about ensuring effective schools in South Africa	159
11	Leaders are in disagreement whether distributed leadership will ensure effective schools in South Africa	161
12	The effectiveness of leadership at South African schools	163
13	Training as a coach	166

LIST OF DIAGRAMS		Page
1	Distributed leadership is about the interaction of leaders at all levels	135
2	Distributed leadership is about the interaction of leaders at all levels	136
3	Distributed leadership is about the interaction of leaders at all levels	138
4	Distributed leadership is about the interaction of leaders at all levels	139
5	Distributed leadership is about the interaction of leaders at all levels	141

LIST OF FIGURES		Page
2.1	Taxonomy of leadership distribution	39
2.2	Three tiers of distributed leadership	39
2.3	Distributed management structure within a primary school	40
2.4	Patterns of shared leadership	49
3.1	Collaborative nature of the 7CS framework	62
3.2	Seven-stage coaching wheel frame	63

LIST OF ABBREVIATIONS		
No	Abbreviation	Meaning
1	7Cs	Seven-Stage Coaching
2	AH	Assistant headteacher
3	ATL	Association of Teachers and Lecturers
4	CT	Classroom Teacher
5	DAS	Developmental Appraisal System
6	DP	Deputy principal
7	DT	Deputy headteacher
8	EEA	Employment of Teacher Act
9	ELRC	Education Labour Relations Council
10	GROW	Goal, Reality, Options and What
11	HLTA	Higher Level Teacher Assistant
12	HODs	Head of Departments
13	HT	Headteacher
14	IQMS	Integrated Quality Management System
15	OD	Organisation development
16	OSCAR	Outcomes, Situations, Choices and Consequences, Action and Review
17	P	Principal
18	PMS	Performance Management System
19	SENCO	Special Educational Needs Co-ordinator
20	SJL	Subject Leader
21	SMT	Senior Management Team
22	STRIDE	Strengths, Target, Real Situation, Ideas, Decisions and Evaluation
23	TA	Teacher Assistant
24	WSE	Whole-School Evaluation

Chapter Six
Summary, findings and recommendations

Chapter Five
Data presentation, analysis and interpretation

Chapter Four
Study Methodologies

Chapter Three
Coaching as distributive leadership strategy, assuring effective schools

Chapter Two
Theoretical framework of the theories and practices of distributed leadership as strategy in schools

Chapter One
Orientation, problem formulation and aims of the study



CHAPTER ONE

ORIENTATION, PROBLEM FORMULATION AND AIMS OF THE STUDY

1.1 INTRODUCTION

The researcher taught in both South Africa and the United Kingdom, where he personally experienced and observed school leadership styles and the effects thereof over a period of twenty years. He was employed as a principal at a very dysfunctional rural school in South Africa for a period of three years. The researcher decided to further his career in England in 2002 and gained British Qualified Teacher Status. In 2010 the researcher was promoted and employed as a middle leader at a school in London until 2012. The researcher decided to make a career change and accepted an offer as a classroom teacher in the United Arab Emirates in 2012. This offer gave the researcher an opportunity to gain knowledge and practical insight about the American Curriculum. The school in the United Arab Emirates functions on the American Curriculum and the researcher also accepted a primary classroom teacher position within the school which gave the researcher an opportunity to strengthen his insight about leadership styles across the globe. The researcher has always wanted to investigate distributed leadership as strategy to ensure effective schools by means of a comparative study between primary schools in South Africa. This study endeavours to gain some insight into distributed leadership and the researcher hopes that, through this study, a positive contribution can be made by means of the development of a model that could be applied to understand and promote distributed leadership as a strategy at schools in South Africa.

In recent times, principals have been called upon to take on more and more responsibilities in order to manage their schools effectively and to enhance learner achievement. Principals are also required to serve as leaders for the learning of the learners.

Furthermore, it is expected of principals to be experts in curriculum content and best classroom practices. In addition to these expectations, principals are also required to assist teachers in improving their teaching skills as well as addressing other multiple managerial tasks, demands and responsibilities.

The management of schools greatly influences learner academic outcomes. Rutter *et al.* (1979) and Wekesa (1993) noted that to improve learners' performance principals are required first to improve the management of the schools. This can be done by setting a clear vision for the schools and communicate this vision to learners, support its achievement by giving instructional leadership, resources and being visible in every part of the institution that account for learners' performance. It is therefore not surprising that school principals are required to have a range of leadership styles and skills in order to meet all the above-mentioned demands of daily school life.

A study by Ruff and Shoho (2005) involving a novice principal and two experienced principals in three urban elementary schools at San Antonio, Texas, showed the importance of mental models of principals in constructing their roles as instructional leaders. The mental models refer to: observations, assessments, designs, and implementation, while the principals' practice styles refer to goals, factors to influence, strategies and the nature of decision-making by being reactive, proactive and consistent.

Another study by Fisher and Frey (2002) at Hoover High School in San Diego reveals that the principal as an instructional leader led to increased learner academic achievements while decreasing drop-out rates. In this context, the principal regularly modelled lessons in front of teachers and learners and interacted with learners to provide encouragement and strategies to achieve success. Principals can no longer be expected to lead and manage schools on their own. Eerly and Weinding (2004:20) are of the opinion that "delegated team management is essential for a successful school".

Furthermore, the emergence of standards-based accountability has increased the demands placed upon school administrators. Study conducted by PricewaterhouseCoopers (2007) into school leadership identified a number of key roles and responsibilities of school leaders.

These encompass a range of both strategic and operational areas:

- Strategic direction and ethos;
- Teaching and learning;
- Developing and managing people;
- Networking and collaboration,
- Operations; and
- Accountability.

There are more responsibilities and accountabilities on leaders to ensure that a school is managed effectively. The distribution of leadership can be used as strategy to ensure effective schools in South Africa and the United Kingdom. In the next section the background of the study will be discussed.

1.2 BACKGROUND TO THE STUDY

As the concepts of leadership and specifically distributed leadership in the school context are the focus of the study, these two issues will firstly be discussed from a school perspective as background to the study

1.2.1 Leadership

One of the traditional and widely accepted definitions for leadership is that of Greenberg and Baron (1993: 444) who describe leadership as "*the process whereby one person influences individual and group members towards goal setting and goal achievement with no force or coercion*". According to this definition, leadership is not a matter of passive status or of the mere possession of some combination of traits. It appears rather to be a working relationship

among members of a group, in which the leader acquires status through active participation and demonstration of his capacity for carrying cooperative tasks through to completion. According to Hersey, Blanchard and Johnson (2001: 9) leadership occurs "*whenever one person attempts to influence the behaviour of an individual or group, regardless of the reason*".

In summary it can be concluded that leadership is generally defined as the process of directing the behaviour of others towards the accomplishment of goals. It involves elements such as influencing and motivating people, either as individuals or as groups, managing conflict and communicating with subordinates. Muijs and Harris (2003) are of the opinion that leadership has been premised on a singular view of leadership and upon individual thrust. Coleman (2003) proposes that the amalgamation of authoritarianism, centralisation and a masculine leadership style promotes the idea that leadership is vested in the principal. Lightfoot (1983:323) explains that it is an essential that a good school needs a strong, consistent and inspired leadership team. Donaldson (2006:8) adds that leadership helps the school adapt to its changing function in society. According to Astin and Astin (2000), leadership ensures the stability, preservation and maintenance of the school. Educational leadership entails all these aspects in an educational setting or school context. Defining the concept of leadership or educational leadership is one of the most challenging tasks facing educational study, educational practitioners or even educational leaders.

It is such a complex concept that its definition, as well as its description, depends on how, when and by whom it is viewed and one's ability to defend a particular viewpoint. Leadership depends also on the position from which it is viewed and the conditions under which the definition or description is made (Pushpanadham 2006). It is this complex nature of educational leadership that drives continuing and sustained study in this area.

Harris and Muijs (2005:133) argue that *“both senior managers and teacher have to function as leaders and decision makers and try to bring about fundamental changes. School improvement requires a conceptualisation of leadership whereby teacher and managers engage in shared decision-making and risk-taking”*.

1.2.2 The nature of distributed leadership

The term or concept distributed leadership attracts a range of meaning and is associated with a variety of practices. Mayrowetz (2008) states that different uses of this term have emerged. Distributed leadership refers to an emerging theory of leadership with a narrower focus on individual capabilities, skills, and talents. Instead this type of leadership focuses on a joint responsibility for leadership activities. According to MacBeath, Oduro and Waterhouse (2004), distributed leadership means the same as dispersed leadership, shared leadership, collaborative leadership and democratic leadership. Kelly (2002) adds that distributed leadership also conceptualises with delegated leadership in terms of transfer of managerial tasks and responsibilities. Harris (2002) is of the opinion that less focus is directed on the characteristics of the leader and more upon creating environments for shared learning and developing leadership capabilities. Spillane and Diamond (2007) state that part of the appeal of the distribution are about things and people in leadership roles.

According to McLennan (2000:58), the governance of schools in South Africa is primarily concerned *“with the distribution of authority and voice. Authority includes explicit authority such as financial and policy decisions, as well as implicit authority, involving the culture and values that determine the ethos of a school. The underlying principle is to ensure that teacher, parents, learners and non-teaching staff actively participate in the governance and leadership of schools with a view to providing a better teaching and learning environment”*. Gronn (2000:324) describes *“distributed leadership as an emergent property of a group or network of individuals where which group members pool their expertise”*.

Authors such as Lieberman, Saxl and Miles (2000), as well as Blasé and Blasé (2001) and Grant (2006), is of the opinion that distributed leadership is based on trust and requires distribution of leadership tasks by senior leadership, rather than just delegating tasks. Spillane (2005) is of the opinion that leadership needs not be located only in the principal of a school, but should be stretched over multiple leaders and this distributed leadership perspective foregrounds leadership practice, which is constructed in the interactions between leaders, followers and their situations.

Hoskings (1988) suggests that distributed leadership focus on a model that is network based. For Bennet, Wise, Woods and Harvey (2003:7), "leadership is an emergent property of a network of interacting individuals with an openness of boundaries and expertise are distributed across many not the few". According to Parry and Bryman (2006:448), "*five strands in recent study which illustrate the development of distributed leadership*". Firstly, Manz and Sims (1991) suggest a form of leadership that is expected to exceed the individual heroic model. New models of leadership recognise that workplace effectiveness depends less on individual, heroic action and more on collaborative practices distributed throughout a school. According to Pearce and Sims (2000), the belief that we do not need another hero has ushered in an era of what is often called post-heroic or shared leadership.

For Badarraco (2001), this new, more relational approach is intended to transform stodgy, top-down school structures into flexible, knowledge-based entities able to meet the demands of the information age and global economy. Sims and Lorenzi (1992:296) are of the opinion that followers are stimulated to become leaders themselves. The researcher wants to add that followers must also be developed by middle leaders to become leaders themselves.

Secondly, Parry and Bryman (2006:454) state that "*leaders develop capacity in others and have the capacity to turn their constituents into leaders*". They are also of the opinion that the development of leaders creates an opportunity to move away from heroic senior leaders and towards teams as sites of leadership

(Parry, 1998). The researcher is of the opinion that development of teams will create the opportunity for distribution of leadership to take place.

Thirdly, Hoskings (1988; 1991) states *“that building on the theme of leadership as social process is a notion of distributed leadership that emphasises leadership processes and skills, as well as orientation that encapsulates a perspective beyond formal roles of designated leaders”*.

According to Knights and Willmott (1992), the orientation of distributed leadership leans towards the practices of leadership embedded in specific school contexts. The researcher wants to add that it is the responsibility of leaders to decide which tasks can be distributed to meet the needs of the school. The leader must also have the skill and the ability to decide which teacher will be the correct connection for the distribution.

Gordon (2002) draws a distinction between distributed and traditional leadership through revealing the deep power structures of schools. Such structures that affect leader-follower relationships serve to maintain traditional notions of differentiation between leader and follower in terms of power and information asymmetry. Such asymmetries are brought into further tension through the contrast of espoused empowerment encapsulated in discourses of flattening of hierarchy and the act of delegation. Parry and Bryman (2006:455) state *however, the deep power structures reinforce pre-existing leadership relativities in spite of the rhetoric and discourse of the distribution of power that those in senior positions would have followers believe*.

The issue of power and information asymmetries is potentially in flux through the fourth expression of distributed leadership: leadership within the context of e-commerce (Brown and Gaia, 2002). Parry and Bryman (2006:455) *“identify particular challenges for leadership. On the one hand, leaders are able to get information to large groups of followers quickly and in large volume. On the other hand, group members can access large amounts of information independently of their leaders. In effect, leaders lose much control over information flow and the power that goes with it”*.

According to Avolio, Kahai and Dodge (2001), technology becomes part of the social transformation in the school and, in turn, part of the leadership process. The researcher is of the opinion that the use of technology forms a vital part of leadership in schools and it saves a lot of time and is much easier to manage in a day-to-day situation. It is also important that meetings still take place on a regular basis, such as briefings and faculty and year-team meetings.

Distributed leadership derives its theoretical underpinnings from concepts of distributed cognition and activity theory. In this theory, the social environment is a vital component of intellectual activity. While cognition can be distributed situational in the physical environment, through the environment's material and cultural artifacts, it can also be distributed through other people as they collaborate to complete tasks (Latuour, 1987; Pea, 1993). Furthermore, study by Vygotsky (1978) reveals that practice, or socio-cultural activity, rather than the individual, should be the focus of leadership analysis. The focus of analyses for leadership practice should be from the individual to the event. Recent work by scholars at the Laboratory of Comparative Human Cognition expanded upon this belief by postulating that cultural practices should be the focus of analysis (Sherer, 2004).

Studies about distributed leadership and socio-cultural activity theories are beneficial to understanding human activity in complex and constantly changing situations and form the intellectual roots of work on distributed leadership. The customary role of the school principal in South Africa has changed under the culture of the democratic order. Swanepoel and Booyse (2006) are of the opinion that the culture of the democratic order displayed in South Africa requires school principals to exercise leadership that fully promotes the participation of all stakeholders. The assumption can be made that teacher leadership can be implemented as a strategy to promote the participation of stakeholders in leadership roles within schools. Two forms of distribution can occur in schools.

The first type of distributed leadership is collective distributed leadership (Spillane et al., 2004). Collective distribution characterises a practice that encompasses the work of two or more leaders who enact a leadership routine by working separately but interdependently. Distributed leadership is a change in the school thinking, which redefines leadership as the responsibility of everyone in the school. According to Elmore (2000), leadership can be distributed through the components of leadership practices, mission, vision, goals, school culture and shared responsibility. Although the majority of researchers agree distributive leadership means that leadership should be distributed throughout the whole school, there are various ways this can be attained. Examples of distributive leadership can cover the spectrum from a principal simply encouraging the staff to take leadership responsibilities to an entire district implementing a new decision-making structure for all its schools. It may mean that heads of departments (HODs) take over some of the principal's responsibilities to enhance the development of the curriculum of the school. House and Aditja (1997:457) state *"that distributed leadership is the process of leadership which involves collaborative relationships that lead to collective action grounded in the shared values of people who work together to effect positive change"*. According to Leithwood and Reid (2003:3), *"teacher leaders can help other teachers to embrace goals to understand that changes are needed and that teachers work together towards whole school improvement"*. Furthermore, Sillins and Mulford (2002) are of the opinion that learner outcomes are more likely to improve where leadership sources are distributed throughout the school community and where teachers are empowered in areas of importance to them.

The second type of distributed leadership is coordinated distributed leadership. Coordinated distribution refers to leadership routines that involve activities that have to be performed in a particular sequence. The interdependency in this situation is similar to that in a relay track race; the co-performance of the relay depends on a particular ordered sequence (Spillane et al., 2004). Gronn (2002:655) suggests *"that in the distribution of leadership it is not only the leadership of principals that counts, but also the leadership roles performed by*

deputy principals, substantives, support staff, members of school councils, governing bodies and learners”.

Harris and Muijs (2003) state that leadership, from a distributed perspective; reside in the human potential available to be released within a school. Implicit within the distributed leadership model are the leadership practices, either as informal leaders or in a formal leadership role as a principal, head of department, subject coordinator or mentor. The implication from the current school improvement literature is that distributed leadership can assist schools in building the internal capacity for development.

“Relating the above argument to the notion of effective schools in South Africa, one is tempted to make the assertion that principals find it difficult to implement certain policies outlined by the department of education, or the policies are implemented and not monitored to see if they have are successful” (Heystek, 1999:56).

Harris and Lambert (2003:43) are of the opinion that “teacher leadership is a model of leadership in which teaching staff at various levels within the school have the opportunity to lead. Teacher leadership focuses on improving learning and is a model of leadership is based on the principles of professional collaboration, development and growth (ibid.)”.

In this study, the researcher wants to analyse whether the distribution of leadership as a strategy can ensure effective schools in South Africa. In the light of the conceptualisation of leadership in general, and distributive leadership in particular, the study problem will consequently be identified and explained.

1.3 THE STUDY PROBLEM

Krause and Powell (2002), Mestry and Grobler (2002) and Sayed (2000) indicate that the South African leadership study base is very limited. Studies on the availability of training and development and the needs of school managers dominate the field. What these studies show is that most principals do not receive adequate specialist training, especially in financial leadership and instructional leadership. Much study on the foregoing issues focuses on policy rather than actual practice. Furthermore, authors such as Bush and Odura (2006, in Mestry and Prakash, 2007:478), states that little formal leadership or management training exists and principals are appointed on the basis of their teaching record, rather than their leadership or managerial potential. Induction and support are usually limited and principals have to adopt a pragmatic approach. Principals involved in the day-to-day leadership of their schools need to take time to reflect on their personal growth as leaders and managers.

According to Muller and Marais (2004), school effectiveness study seeks to identify and isolate the relative effects of different practices on learner attainment and on overall school effectiveness. These studies tend to identify four sets of features influencing school effectiveness: learner characteristics (including home background and levels of prior attainment), management practices, school inputs (including teachers, physical infrastructure and the availability of teaching and learning resources) and teaching processes (the manner in which the curriculum is designed, delivered and assessed). Schools can be more effective by creating models which will empower leadership teams to make schools more powerful to meet school goals.

By means of this study, the researcher wants to create a model that will serve as the frame of reference for the empowerment of leadership teams at schools, especially in the KwaZulu-Natal Province in South Africa. The researcher received instructions from the acting Deputy-General to provide the Department of Education of KwaZulu-Natal with a report on the findings and recommendations regarding this study (See Appendix B – Letter granting permission to do study in KwaZulu-Natal). The model will therefore entail those

important managerial skills which will enable managerial teams to effectively distributed leadership tasks and to enhance the forces that drive and change education.

In addition to an increased demand for meeting standards, principals are also asked to work collaboratively in an attempt to develop leadership in others. This request is based upon study revealing that school improvement takes place through collaborative learning communities (Lashway, 2003). Results of study by Murphy and Datnow (2002:7) indicate *“that successful principals meet the increased demands by building dense leadership schools, which is a social phenomenon woven into the threads of the school”*.

When studying distributed leadership, it is important to investigate whether leadership is not held by one leader only, but if leadership roles and decision making is distributed among the rest of the senior leadership team. This study will focus on the distribution of leadership at five selected schools in KwaZulu-Natal. Due to the structure of the primary school curriculum, it is vital for the senior leadership team to be aware of various leadership techniques available to operate effective primary schools.

The major study problem which emanates is therefore:

What is the role of distributive leadership as strategy to ensure effective schools in South Africa?

The study will be guided by the following sub-questions in order to determine the views of senior leadership teams, middle leaders and classroom teacher and classroom assistants on the distributed leadership approach as a leadership strategy:

- What are effective school leadership, leadership strategies and distributed leadership? (To be addressed in chapter 2).
- How can distributed leadership support change and improve effective schools? (To be addressed in chapter 2).

- How can coaching been used as a successful and effective distributed leadership strategy? (To be addressed in chapter 3).
- How does one design, implement and maintain coaching as a distributed leadership strategy to ensure effective schools in South Africa? (To be addressed in chapter 4).
- How can a distributed leadership model be conceptualised as a leadership strategy in South African schools to ensure effective schools in South Africa? (To be addressed in the empirical study in Chapter 5).

1.4 AIMS AND OBJECTIVES OF THE STUDY

The primary goal of the study is to determine the views of leaders on the distribution leadership approach as a leadership strategy:

- To define effective school leadership, leadership strategies and distributive leadership;
- To explore how distributive leadership support change and improve effective schools;
- To investigate how coaching can be used as an effective and successful distributed leadership strategy;
- To explore ways in which one design, implement and maintain coaching as a distributed leadership strategy to ensure effective school leadership in South Africa; and
- To explain how a distributive leadership model can be conceptualised as leadership strategy to ensure effective schools in South Africa.

Next, the study methodology will be discussed.

1.5 STUDY METHODOLOGY

1.5.1 Study approach

A literature study of books, journals, investigations of scripts, dissertations and theses, newspapers, official documents and other media will provide the theoretical background with regard to the study. Literature will be used to stimulate questions and provide the basis for supporting the empirical study.

A study design is the logic that links the data to be collected and conclusions to be drawn to the initial question of the study, a distributive approach to effective school leadership. In terms of a study design, the study lends itself to qualitative study methods of data collection, analysis and interpretation of the findings, because the intention of the researcher is not to predict, but to understand and explain educational phenomena. *“The researcher has opted for a qualitative study design, because he is interested in asking broad, general questions, collect data from participants during interviews, and analyse data by describing interactions and developing themes”*(Creswell, 2008:64). Furthermore, qualitative study designs are used for this study, *“because these designs are flexible with orientated interviews and open-ended questions which enable the researcher to understand the context of the investigation”* (Henning, van Rensburg and Smit, 2004:5).

This study investigates the role of distributive leadership as a strategy to ensure effective schools: a comparative case study within selected South African schools. The researcher will explain the study population and the sample in more detail in the next section.

1.5.2 Study population and sample

The population of the study will consist of all of the 27 primary schools in the Pumela Ward, in the District of Amajuba and in the province of KwaZulu Natal in South Africa. The researcher has decided to use primary schools in the study because of his own work experience at primary schools, particularly with learners between the ages of six and fourteen years. It is also important to note that when

the researcher was employed as a principal in South Africa, he managed a combined school with learners between the ages of six and fourteen years.

For logistical reasons, such as resources and time, only five well-performing functional primary schools in the Pumela Ward of the Kwazulu-Natal province will form the sample and have been selected purposefully. Purposeful sampling is based on the assumption that the researcher wants to discover, understand and gain insight and therefore he must select a sample from which the most can be gained. To begin purposive sampling, the selection criteria for choosing the people or sites to be studied must be determined (Le Compte and Preissle, 1993).

The focus is the role of distributive leadership to ensure effective schools. The researcher contacted the principals of the schools and applied for permission to conduct interviews at the schools. The principals also confirmed that the schools were evaluated against the National Framework. The principals were fully informed of the purpose and nature of the study.

All five primary schools mentioned above were evaluated against the National Department of Education's whole-school evaluation criteria. All five schools have received guidelines which have to be used when a school is being evaluated according to the National Framework, in order to ensure that evaluations are carried out consistently and supervisors are using the same criteria when reaching conclusions.

The focus areas during the evaluations are:

- Basic functionality of the school; leadership, management and communication;
- Governance and relationships;
- Quality of teaching and educator development;
- Curriculum provision and resources;
- Learner achievement;

- School safety, security and discipline;
- School infrastructure; and
- Parents and community.

The evaluation guidance forms the theoretical basis to evaluate whether schools can be classified as functional or dysfunctional. The recently-introduced policy innovation to enhance the delivery process of a quality education for South African schools is the Integrated Quality Management System (IQMS). IQMS is informed by schedule 1 of the Employment of Teacher Act (EEA), No. 76 of 1998. In terms of resolution 8 of 2003, an agreement was reached in the Education Labour Relations Council (ELRC) to integrate programmes on quality management which comprise the Developmental Appraisal System (DAS), the Performance Management System (PMS) and Whole-School Evaluation (WSE). The tenets of IQMS are underpinned by the purpose of quality management systems, which are to determine competence, to assess strengths and areas for further development, to ensure continued growth to promote accountability and to monitor the overall effectiveness of an institution (Kaplan and Norton, 1996).

Quality comes through process improvements intended to make a sustainable difference to the outcome of these processes (Murgatroyd and Morgan, 1993). For schools that have quality initiatives and quality programmes in place, measurement would be a central part of any such programme (Kaplan and Norton, 1996).

The total sample of participants to be interviewed will comprise twenty-eight (28) leaders from the five selected schools in South Africa, which will include principals, SMT members, and head of departments, grade leaders, subject leaders, classroom teachers and classroom assistants.

The researcher clustered classroom teachers and classroom assistants into one focus group. The researcher decided to clustered teachers and classroom assistants into one focus group. The purpose was to identify how distribution takes place between teacher and classroom teacher in the daily management of

teaching and learning within a normal classroom setting. This means that twenty-eight interviews were conducted at the five selected schools, resulting in a total of 28 interviews. On his initial visit to the schools, the researcher explained the purpose of the interviews on the day of the visit to the principals. The researcher also explained to the principals the need to interview leaders at all levels, as mentioned above. After the meeting, the principal allocated the six members of the sample to be interviewed. It is important to note that the sample was selected by the principal in such a way that no disruption occurred at the school during school hours and that teaching and learning continued as normal with the minimum disruption.

The researcher also evaluated official school documents against the criteria for classification for a well-performing school, as identified by the National Department of Education. The data obtained from the interviews in South Africa will be used to conduct the comparative case study between the South African schools. The researcher wants to make the assumption that distributed leadership can be used as strategy (coaching and mentoring) to ensure effective South African Schools. The total sample for the study will therefore be twenty-eight (28 leaders) from South Africa.

1.5.3 Instrumentation and data collection technique

A qualitative study design permits data collection through observation and analysis of the collected data by describing interactions and developing themes, making use of established theoretical framework from the literature.“ *The qualitative study design also involves open-ended and free-response, unstructured and structured interviews as well as the analysis of documents and allows the subject to speak for itself*” (Neuman, 1997:14).

A qualitative study approach is used in this study, as it provides participants with the freedom to present data from their perspective. In addition, data collection is open and flexible, taking into account the relationship between the researcher and the participants. The interview will be used as the main data collection technique in this study. Data will be collected in three stages during the study.

During phase one the researcher will prepare the interview schedule. The initial preparation includes permission from the KwaZulu-Natal Department of Education to carry out the study project and involved writing an official letter to request such permission. Phase one will last one month.

The conduct of the interviews itself formed the second phase of the data collection process. The researcher conducted 28 semi-structured interviews at five functional schools to get information on the state of effectiveness of the schools in South Africa.

Open-ended questioning allowed the respondents to give detailed answers and to share their opinions on the subject of distributed leadership as a leadership strategy. Therefore, phase two of the data collection process in South Africa lasted one week.

During phase three of the data collection process, the researcher collected documents from functional schools. Documents are a very important source of information and, considering the study question and the purpose of the study, the researcher made use of documents such as the school policy for all schools to establish how distributive leadership is managed.

Documentary analysis was used because it produced data with high validity as data were readily available and, unlike data from interviews, data collected by means of documentary analysis are not prone to manipulation by study subjects.

Next, the researcher explains the analysis and interpretation of the data.

1.5.4 Data analysis and interpretation

Discursively orientated interviews will be conducted to provide the researcher with more information. In this study, participants will be interviewed by making use of open-ended questions and probing if the need arises as this will encourage independent cognitive articulation, according to Henning (2005:5).

Documents are a very important source of information and, considering the study question and the purpose of the study, the researcher made use of documents

such as the school policy for all schools to establish how distributive leadership was managed in the schools.

The collected data were be captured and saved through a word-processing computer programme (Microsoft Word). An inductive approach was adopted in the analysis of the collected data. According to Marshall and Rossman (1995), an inductive approach is a systematic procedure for analysing qualitative data where the analysis is guided by specific objectives.

The primary purpose of the inductive approach is to allow study findings to emerge from the frequent, dominant or significant themes inherent in raw data. De Vos, Strydom, Fouché and Delport (2002) are of the opinion that categorisation and the principle of tabulation, which involves classifying the participants in relation to separate variables for the purpose of determining their degree of association, will be employed in analysing the collected data. A contingency table for obtaining a meaningful interpretation of data will be used to this effect.

The researcher made use of the eight steps as provided by Tesch (1990, in Creswell, 2003) to analyse the qualitative data. The steps in analysing data recommended for a coder of data by Tesch are as follows:

- That the coder gets a sense of the whole by reading through all the transcriptions carefully, jotting down some ideas as they come to mind.
- Select one document, one interview – perhaps the most interesting, the shortest, the one on top of the pile and the go through it, asking oneself, “What is this about?” Do not think about the “substance” of the information, but rather its underlying meaning. Write thoughts in the margin.
- When this task has been completed for several informants, make a list of all topics. Cluster together similar topics into columns that might be arranged as major topics, unique topics and leftovers.

- Take this list and go back to your data. Abbreviate the topics as codes and write the codes next to the appropriate segments of the texts. Try out this preliminary organising scheme to see whether new categories and codes emerge.
- Find the most descriptive wording for your topics and turn them into categories. Look at ways of reducing your total list of categories by grouping topics that relate to each other. Perhaps draw lines between lines to show interrelationships.
- Make a final decision on the abbreviation for each category and alphabetise these codes.
- Assemble the data material belonging to each category in one place and perform a preliminary analysis.
- If necessary, recode existing data.

The researcher discusses how to analyse the data in this study, as well as the reality and validity of the study.

1.6 RELIABILITY AND VALIDITY OF STUDY

According to Schurink, Schurink&Poggenpoel (1998:331), "*Guba's model of trustworthiness, namely truth-value, applicability, consistency and neutrality, will apply to this study. Truth-value refers to whether the researcher has established confidence in the truth of the findings for the subjects and context in which the study will be undertaken*".

Krefting (1991:215) is of the opinion that "*the truth-value should be a true reflection of human experiences of the events, as they establish the confidence of the researcher with regard to the findings based on the study design, informants and context. In this study, the human perceptions applied to this study are those of the principals, deputy principals, head of departments and phase leaders*".

Triangulation is a strategy that enhances credibility. Krefting (1991:219) states that *“triangulation ensures that the researcher investigates all aspects of the phenomenon under study and also ensures that data remain as it is, because it is crosschecked”*.

In this study, the researcher employed several data-collection techniques by gathering information from different participants and multiple sources of data. The multi-methods strategies used to collect data in this study were a literature review, field notes, documents and recorded interviews with several participants.

“Applicability demonstrates the transferability of the degree to which the findings can be applied to another context, setting and group” (Schurink et al., 1998:331).

“The study meets the criteria when the study findings fit into a context outside the study situation, which is guided by the degree of similarity” (Krefting, 1991:216).

Krefting further states that applicability is enhanced through fittingness, triangulation and dense descriptions of the results as well as discussions of the findings with peer groups. In this study, applicability will be maintained by selecting cases that reflect the resemblance to the schools that were not selected.

Krefting (1991:216) also *“postulates that in consistency, dependability is very important, because it enhances consistency and considers the consistency of the data that is whether the findings would be the same if the enquiry is to be repeated with the same subjects”*.

In this study, a clearly defined audit trail of data collection, analysis and interpretation was employed to enhance the consistency of the findings. *“Neutrality refers to the degree to which the findings are only the functions of informants and conditions of the study”* (Krefting, 1991:216). *“In that way, it (neutrality) considers the degree to which the findings are ensured by confirmation. Neutrality is established by triangulations, confirmability audits and the use of field notes”* (Schurink et al., 1998:331). Therefore, in this study, neutrality was maintained by allowing another researcher to confirm the findings.

An explanation was given regarding the reality and validity of the study. A detailed planning outline of the study is given in the next section.

1.7 PLANNING OF THE STUDY

Chapter 1 provides the study problem, the aim of the study and the methodology to be used. It outlines certain assumptions involved and clarifies the concepts of the study title.

In chapter 2, the researcher explores the meanings of effective school leadership, leadership strategies and distributed leadership. In chapter 2 the researcher also investigates how distributed leadership can support change and improve effective schools.

Chapter 3 deals with how distributed leadership can be used as a successful and effective strategy in South African schools, as well as with the ways in which schools leaders are willing to adopt a distributed leadership approach to ensure effective school leadership in South Africa.

Chapter four outlines the study design and methodology used in this study to investigate the role of distributed leadership to ensure effective schools in South Africa. A qualitative study design is used to address the following sub-study questions:

- How can distributed leadership support change and improve effective schools?
- In what ways are school leaders willing to adopt a distributed leadership approach to ensure effective school leadership in South Africa?
- How can distributed leadership been used as a successful and effective leadership strategy

Chapter 5 deals with an empirical investigation of how a distributed leadership model can be conceptualised as a leadership strategy to ensure effective South African schools.

The findings and recommendations are discussed in the last chapter and a model is introduced as to how mentoring and coaching can be used as a strategy to ensure effective schools in South Africa.

An outline of the study was given above. Next, definitions of the main concepts follow.

1.8 DEFINITIONS OF THE MAIN CONCEPTS

1.8.1 Distributed leadership

Copland (2003) defines distributed leadership a set of functions or qualities shared across a much broader segment of the school community, which encompasses teacher and other professionals and community members, both internal and external to the school. Such an approach imposes the need for school communities to create and sustain distributed leadership systems, process and capabilities.

1.8.2 Leadership strategies

Reviews of study suggest that successful school leaders influence learner achievement in several important ways, both through their influence on other people or features of their schools, and through their influence on school processes are leadership strategies. Leithwood et al. (2004) outline three sets of core leadership practices. The development of people are enabling teacher and other staff to do their jobs effectively, offering intellectual support and stimulation to improve the work, and providing models of practice and support.

The setting of directions for the school such as developing shared goals, monitoring school performance and promoting effective communication are effective leadership strategies to promote school development.

The redesigning of the school through creating a productive school culture, modifying school structures that undermine the work, and building collaborative processes are leadership strategies which can develop and improve the school as a learning school.

1.8.3 Effective schools

Effective schools are learning communities, the core element of which is a culture of collaboration and collective responsibility for the development of effective teaching practices and improved learner achievement. Teachers cannot be expected to create vigorous learning communities among learners if they have no parallel community that nourishes them professionally (Department of Education & Training, 2004).

Learning communities of practice define competence by combining three elements (Wenger, 1998). Firstly, members are bound together by their collectively developed understanding of what their community is about and they hold each other accountable to this sense of joint enterprise. To be competent is to understand the enterprise well enough to be able to contribute to it. Secondly, members build their community through mutual engagement. They interact with one another, establishing norms and relationships of mutuality that reflect these interactions.

To be competent is to be able to engage with the community and be trusted as a partner in these interactions. Thirdly, communities of practice have produced a shared repertoire of communal resources— language, routines, sensibilities, artefacts, tools and stories.

An extensive study base supports the view that leadership is the most important element of an extensive school (Sergiovanni, 1984; Elmore, 2000; Stoll, 2004). Effective leaders articulate the types of improvements required to achieve agreed goals and expectations, as well as develop a common language for describing good teaching and learning practices. They have a clear understanding of the change process and a deep, current and critical understanding of how people learn. According to Senge (1999:1) to meet today's challenges of globalization, changing work forces, evolving competition, and new technologies, the only hope for building and sustaining momentum in a learning organization requires a fundamental shift in thinking and actions. Creating an organization with an emphasis on developing personal mastery, creating mental

models, building shared vision, improving team learning, and understanding systems thinking will have the potential of allowing organizations or schools to be more convivial and creative. Effective leaders engage their staff in professional discourse, drawing on external ideas and study to inform their thinking and actions and encourage them to reflect on what they are trying to achieve with learners, as well as how they are doing it. The learning community is as an organization in which all members acquire new ideas and accept responsibility for developing and maintaining the organization. The focus is on harnessing experiences of the members. In a learning organization, members work together, mutually understanding each other, yet respecting the diversity of one other. Every individual's contribution is significant to the life and well-being of the organization (Argyris and Schon, 1996). Therefore, in an effective learning community, there should exist a tight connection between the energy of its members and the organization's direction.

1.9 CONCLUSION

In this chapter, the background of the problem was discussed and the study questions were developed in accordance with the study problem. The aims and the objectives of the study were stated and the study design and methodology were outlined. A breakdown of the six chapters of this study was given and certain key concepts have been clarified.

The following chapter will explain effective school leadership, leadership strategies and distributed leadership in more detail. An explanation will also be given of how distributed leadership can support change and improve effective schools.

CHAPTER TWO THEORETICAL FRAMEWORK OF THE THEORIES AND PRACTICES OF DISTRIBUTED LEADERSHIP AS STRATEGY IN SCHOOLS

2.1 INTRODUCTION

Chapter 2 is a literature review of the theories and practices of distributed leadership and how distributed leadership can be utilised as leadership strategies in schools. The chapter addresses the question of effective school leadership and distributed leadership. Furthermore, the question of how distributed leadership supports change and improves leadership of schools is explained.

The theoretical framework of distributed leadership is conceptualised and defined. The relationship between change and school improvement is put in context. The chapter also discusses the leadership strategies that could be used to improve schools and concludes by highlighting the relationship between distributive leadership, leadership of schools and improvement of schools.

Harris and Lambert (2003) argue that leadership is about learning together and constructing meaning and knowledge collectively and collaboratively. Leadership involves opportunities to surface and mediate perceptions, values, beliefs, information and assumptions through continuing conversations. Leadership means generating ideas together, to seek to reflect upon and make sense of work in the light of shared beliefs and new information; and to create actions that grow out of these new understandings.

Leaders must work in ways that meet the needs of the schools they lead. The question remains, however: -

What is the role of distributive leadership as strategy to ensure effective schools in South Africa?

In an attempt to provide an answer to this, the next section devotes attention to define leadership and school leadership.

2.2 THE CONCEPT OF SCHOOL LEADERSHIP

2.2.1 Introduction

Dunford (2005) argues that the greatest challenge of leadership is how leaders can improve the school system. Hopkins and Higham (2007) propose five leadership roles and schools need leaders who develop and lead a successful educational partnership; choose to lead and improve a school in extremely challenging circumstances; partner another school facing difficulties and improve it; and act as community leaders and work as change agents or consultant leaders.

2.2.2 What is school leadership?

Defining the concept of leadership or educational leadership is one of the most challenging tasks facing educational researchers, educational practitioners or even educational leaders. The concept of leadership is such a complex concept that its definition, as well as its description, depends on how, when and by whom it is viewed and one's ability to defend a particular viewpoint. Leadership depends also on the position from which it is viewed and the conditions under which the definition or description is made (Pushpanadham 2006). It is this complex nature of educational leadership that drives continuing and sustained study in this area. Since there are so many different concepts of educational leadership, no universally accepted definition exists.

Bolden (2004) summarises how the complexity of leadership in general makes it difficult to present a convincing definition, when he says: In short, leadership is a complex phenomenon that touches on much other important school, social and personal processes. It depends on a process of influence, whereby people are inspired to work towards group goals, not through coercion, but through personal motivation. Which definition you accept should be a matter of choice, informed by your own predispositions, situation and beliefs.

Authors such as Bass (in Love 1994) divide leadership definitions into categories such as an act of behaviour, the art of inducing compliance, the exercise of influence, a form of persuasion, a power relation, an instrument of goal achievement and an emerging act of intervention. This provides an idea of the complexity of issues involved in the study of leadership. One of the traditional and widely accepted definitions for leadership is that of Greenberg and Baron (1993) who describes leadership as “the process whereby one person influences individual and group members towards goal setting and goal achievement with no force or coercion”. According to this definition, leadership is not a matter of passive status or of the mere possession of some combination of traits. It appears rather to be a working relationship among members of a group, in which the leader acquires status through active participation and demonstration of his capacity for carrying cooperative tasks through to completion (Hersey, Blanchard and Johnson 2001).

In summary it can be concluded that leadership is generally defined as the process of directing the behaviour of others towards the accomplishment of goals. It involves elements such as influencing and motivating people, as either individuals or groups, managing conflict and communicating with subordinates. Educational leadership entails all these aspects in an educational setting or school context.

Gunter (2005) is of the opinion that educational leadership focuses on the education system and is about education; it is integral to learning processes and outcomes and it is school.

Education leadership is about changing the power structures and cultures that we inherit and that can act as barriers to democratic development. Gronn(2000) states that leadership is one of a family of terms in both academic and common usages which is invoked to designate modes of human conduct, engagement, power, authority, influence, manipulation, force and persuasion. Within this discursive family, leadership has always been the favourite offspring.

Leithwood and Riehl (2005) summarise the core human conduct of school leadership as setting direction, managing teaching and learning, developing people and developing the school. Table 2.1 reinforces that enhancing teaching and learning as a key priority for school leadership.

Table 2.1: The human conduct of school leaders (Leithwood and Riehl, 2005)

Core practices	Key school leadership components
Setting vision	Ensure every child is inspired and challenged through appropriate curriculum and learning of teaching styles and skills that underpin personalised learning. Develop a high degree of teaching quality that improve and sustain sharing of best practices and innovation.
Managing teaching and learning	Enable learners to become learners who are more active and take greater responsibility for their own learning. Involve parents and the community to promote the valuing of positive attitudes to learning and minimise the impact of challenging circumstances on achievement. Develop schools as professional learning communities and provide a range of learning experiences.
Developing the school	Managing resources, workforce reform and the environment to support learning and wellbeing; and extend an school's vision of learning to involve networks of schools collaborating to build, for instance, curriculum diversity, professional support, extended and welfare services.

Bush and Glover (2003) argue that the concept of school leadership is a process of influence leading to the achievement of desired purposes. Successful leaders develop a vision for their schools based on their personal and professional values.

School leaders articulate this vision at every opportunity and influence their staff and other stakeholders to share the vision. The philosophy, structures and activities of the school are geared towards the achievement of the shared vision.

The concept of school leadership enacted through modalities of power such as persuasion and negotiation provides a framework for educational leadership. Leadership is about having vision and articulating, ordering priorities, motivating others to go along with one's decisions, constantly reviewing what one does and holding onto that which one values. The concept of school in South Africa will be clarified in the next section.

2.2.3 The concept of school leadership in South Africa

Day, Harris and Hadfield (2001:6) state that “*leadership is the process of building and maintaining a sense of vision, culture and interpersonal relationships, whereas management is the coordination, support and monitoring of school activities*”. To enact both roles successfully requires a careful balancing act. Ribbens and Gunter (2002) explain that education leadership practice has a number of overlapping parts to which various labels are attached: – educational administration, educational management and educational policy. Effective leadership is generally accepted as being a central component in securing and sustaining school improvement. Muijs and Harris (2003:437) point out that “*evidence from school improvement literature consistently highlights that effective leader’s exercise a powerful influence on schools’ capacity to improve learner achievement.*”

McLennan and Thurlow (2003:1) are of the opinion that South Africa requires a paradigm shift in education management training and believe that the scientific education management approach should be replaced by a new approach that focuses on the leadership role of the manager in change management, relationship building, strategic alignment and continuous learning.

Gunter and Ribbens (2002:387) state that “*leadership engaging with issues of knowledge and knowledge production is a demanding task, as it requires description, understanding and explanation of what is done, how it is done, who does it, where is it done and why is it done*”.

Nkomo, Chisholm and McKinney (2004, in Department of Education 2008) state that education management and leadership are burdened with the task of ensuring that teachers are equipped to facilitate cultural understanding and cooperation both in schools and society. There is a critical need for all school managers to engage in the new society imbued with the values and principles of an enlightened, modern and democratic constitution. Leaders must be ethical in their approach to the work situation.

Grace (1995:55) explains that *“leadership in general must maintain an ethical focus, which is oriented towards democratic values within a community and this has to do with the meaning of ethics historically – as a search for the good life of a community. Ethics refers to a more comprehensive construct than just individual behaviour; rather, it implicates us, as well as how we as a moral community live our communal lives”*. James (2000) highlights six ethical values that underpin the work of the education system in South Africa. These are equity, tolerance, multilingualism, openness, accountability and social honour. These values show how the South African government sees the role of education as one that can strengthen the democratic platform of the nation. According to Jansen and Taylor (2003), the first democratic government in South Africa has made significant advances in the schooling sector and provision is now more equitably provided than at any time in the country’s history.

However, a lack of systematic thinking and implementation capacity has been major barriers in reaching the stated goals of educational reform in post-apartheid South Africa. Furthermore, there is every indication that basic education in South Africa remains one of the most inefficient and ineffective in Africa, despite the per capita amounts spent on South African learners.

The Department of Education (2008) explains that there are three elements which relate to the professional work of any principal, namely:- to take action to develop the school, to ensure that leaders know their school leadership function; and to ensure that leadership functions are fulfilled effectively within the school. Rosenholtz (1989) explains that in general there are two types of schools in South Africa, namely schools that are stuck and schools that are moved through teamwork. Stuck schools are schools with lower levels of learner achievement where teachers work on their own (seldom asking for help) and there is little to no evidence of leadership. In a moving school, there is evidence that teacher work more collaboratively. This includes the principal of the school who helps teacher to achieve goals and consequently learner achievement improves.

Moving schools do not necessarily have all the equipment and resources, but with a teaching force that works together to solve problems many obstacles can

be overcome. Moving schools have principals who lead, as well as teacher who also lead in terms of their classrooms or departments. There is a collaborative approach to leading evident in all parts of the school.

A principle that underlies African leadership and management is called *umuntu*, which means, a person is a person through other human beings or *Umuntungumuntungabantui* n Xhosa. Khoza (2005) states that, too often, Africa sees itself as an outpost of America or Europe, which is evident in the way business behaves. In the corporate world the Eurocentric business practices are seen in decision-making informed by power relations rather than consensus; institutional conflict as a result of power positions; and managerial designs that include strategy, school structure, systems, financial and other controls.

2.2.4 Conclusion

The conditions to ensure quality education were identified as those that are crucial and that have an impact on the outcome of quality education in schools. They assist in setting the professional work standards for any leader and would contribute to the uplifting the quality of education. They provide a favourable setting in which the inputs could lead to quality leadership. When conditions are inadequate, effective teaching and learning will be reduced; thus, the attempts of providing quality education at schools could be influenced negatively and teachers' contribution to the quality of education could be affected. The conditions discussed influence the outcome of quality leadership in schools.

2.3 THE THEORIES OF TRADITIONAL SCHOOL LEADERSHIP

In leadership studies, Jenlink (2002) and Horn (2002) are among the researchers who lead efforts to bring theory and practice, theoreticians and practitioners into a new relationship. The challenge is to test theory against practice and to include the practitioners as partners in theory development. In this study, practitioners are leaders at school level and the theory is the role of distributive leadership as strategy to enhance the development of school leadership.

Gorton, Alston and Snowden (2007) identify trait, behavioural and contingency as study relevant to educational administration. Firstly, the trait approach as leadership study started around 1940 with trait studies on attributes of natural leaders focusing on their personalities, motives, values and skills, but none of these studies could discover universal traits for leadership success. Stogdill (1948) has observed leaders displaying some advantageous managerial traits over non-leaders but none of these traits were clearly superior.

Secondly, the examination of leaders' behaviour was undertaken from the 1950s, which produced two-dimensional models. Bowers and Seashore (1996) have developed a model that examines employee-centric behaviour against job-centric behaviour, leading to a task-relationship dichotomy for leadership behaviour. Owen (2007) has developed a behavioural approach to education, which examines administrative against human behaviour. Administrative behaviour includes planning, organising and coordinating, and human behaviour includes subordinates, motivation and management of conflict.

Thirdly, the contingency approach was examined around the 1970s, which recognised dependency of leadership effectiveness on school situations. House (1971) identifies contextual factors influencing the processes of leadership such as environment, subordinates and tasks.

This particular study is based on the behavioural approach identified by Owen (2007). The researcher wants to assume that, through the distribution of leadership, staff can work together to achieve a common goal. Leadership teams can be motivators who support the whole school to achieve the common goal and ensure that teaching and learning improve to a level that are acceptable on a national standard as identified in the government policies. The next section will clarify the theory of contemporary school leadership in more detail.

Crowther, Kaagan, Ferguson and Hann (2002) consider four popular approaches to contemporary educational leadership: – transformational, strategic, educational and school. This particular study embeds the school and school contemporary leadership theories to achieve the aims and objectives of the

study. According to Bates (1992), culture-building is emphasised by school leadership. Duigan and Macpherson (1992:3) argue that “school leadership implies responsible involvement in the politics of the school”.

Lindsay, Robins and Terrell (2003) argue that school leadership requires culturally proficient leaders who respect and know about individual as well as school cultures to interact effectively in various cultural environments within the school.

Giddens (2003) states that besides cultural proficiency change of orientated leadership encourages school innovation. Due to fundamental social change in the knowledge economy, there is increasing tension between fundamentalism and cosmopolitanism reflecting conflict between universal rules and diversity. The distribution of leadership can have a positive impact on innovation because leaders share leadership tasks and work together as a team to develop the school to be a better learning organisation.

Duckers (1985) comments that knowledge-based innovations may be the hardest to succeed, demanding the availability of all the necessary knowledge. The researcher wants to make the assumption that sharing of leadership could have a positive impact on knowledge gaining

Leaders will work together in smaller teams as leaders and share knowledge and experiences to develop the school through effective innovations processes. According to Pogrow (1996), successful innovations must be highly structured and easily monitored. Heifetz (1994) explains that, emerging from education literature on school leadership is the notion of shared leadership, suggesting enhancement of capability to accomplish effective work collectively. Innovations have been developed and implemented through the coaching and mentoring model as a distributed leadership strategy to ensure effective schools in South Africa. Pounder, Ogawa and Adams (1995: 567) state that “leadership from school principals, teachers, administrators and parents have positive effects on school performance”. The objectives and aims of this study were achieved through school and contemporary leadership theory.

Levine (2005:3) emphasises that *“action study conducted should be driven by practice and useful to practitioners and policy makers”*. The researcher wants to answer the question: What is the role of distributive leadership to ensure effective schools in South Africa? In this particular study, the practice is “effective schools” and useful is “the role of distributive leadership to ensure that schools are effective. This will be discussed in the next section.

2.4. SCHOOL LEADERSHIP THEORY TO PRACTICE WITH ACTION STUDY

Sagor (2000) defines action study as a disciplined process of inquiring, conducted by those and for those taking the action. The primary reason for engaging in action study is to assist the actor in improving or refining actions. In this study, the action was to analyse the role distributive leadership comparatively to ensure effective schools in South Africa. Glanz (2005) suggests that many teacher view the role of leaders in action study as facilitators of the work of teachers and educational leaders should become involved in action study for their own professional development. The researcher decided to improve his own practice as middle leader by investigating and comparatively analyse the role of distributive leadership to ensure effective schools. Stringer (2004) states that action study process is critical for school improvement and lasting change. The researcher has achieved the goal of how a distributive leadership model can be conceptualised as leadership strategy to ensure effective schools in South Africa through this study. Ferrance (2000) has developed a six-step action study cycle.

Table 2.2: Six-step study cycle (Ferrance, 2000)

Steps in study cycle	Evidence in this study
Identifying a focus for their project	Engaged in the process of identifying a focus for their project. In this particular study, the focus is to examine the role of distributive leadership to ensure effective schools in South Africa.
Collecting data	Data collected in this study through qualitative interviews and analysing school documents. Data also collected through qualitative interviews and the case study in chapter 4.
Analysing and interpretation of data	Data analysed by means of coding and comparative analysis between samples in South Africa. Data discussed in the empirical study in chapter 5.
Taking action on the evidence	To write a case study on the sample in South Africa on the effectiveness of the distributed leadership model.
Evaluating the results	Implementation of distributive leadership model to be used in schools in South Africa. Clear focus on coaching and mentoring as strategies to ensure that the distributed leadership model is effective. Coaching and mentoring strategies can ensure that schools in South Africa are more effective.
Identifying the next steps	Use findings and recommendations from this study to clarify new topics for future investigations.

The action learning and study process provides the participants with the opportunity not to be confident in admitting and sharing their shortcomings. The power of action learning and study processes does not only help bring change into classroom practices but also in this study to go beyond professional development.

Leadership is collective and since a group can have more than one leader operating at a time, the researcher is of the opinion that members in a group might be operating as leaders together. Drath and Palus (1994) are of the opinion that collective leadership takes place when members in a group are working together towards a common purpose and goal.

According to Tannenbaum and Schmidt (1958), power can be increased by everyone when working together. Since leaders perform a variety of responsibilities in a school, it may be counterproductive to insist that there is only one leader operating at any one time. For example, a classroom assistant, who knows the abilities of individual learners can help teachers figure out how to solve a problem and may be just as important to the group as the leader. However, the leader does not relinquish the leadership role as members of the group turn their attention to the classroom assistant. The two of them as well as many others can offer their leadership at the same time.

In this study, the common goal was to ensure that leadership is distributed to ensure effective schools in South Africa. Block (1996) states that leadership is collaborative when the views of all leaders and staff members count to achieve a common goal. In this study, the effectiveness of schools was achieved through the coaching and mentoring model as a distributed leadership strategy to ensure effective school in South Africa. The concept of distributed leadership will be discussed in more detail.

2.5 DISTRIBUTED LEADERSHIP IN SCHOOLS

2.5.1 Introduction

The Association of Teachers and Lecturers (2007) is of the opinion that distributed leadership is a term often used loosely to describe the traditional management structure redesigned to involve more people in decision-making and leadership roles within schools.

Spillane, Halverson and Diamond (2004) have highlighted in their study the ways in which leadership is constructed from the widespread distribution throughout schools and the extent to which leaders influence the contribution of others, so that leadership may be said to be stretched over the social and situational contexts.

The National College for school leadership (2004) also conducted a study and find that there are six ways to distribute leadership:

- Formal;
- Pragmatic;
- Strategic;
- Incremental,
- Opportunistic and
- Cultural.

These six ways can also be considered phases in a development process. To begin, a school would need to create awareness of distributed leadership. In later phases, work to build trust, confidence, knowledge, and attitudes, enriched by feedback, would move it in increments from formal to cultural distribution.

Figure 2.1: Taxonomy of leadership distribution (The National College for school leadership, 2004)

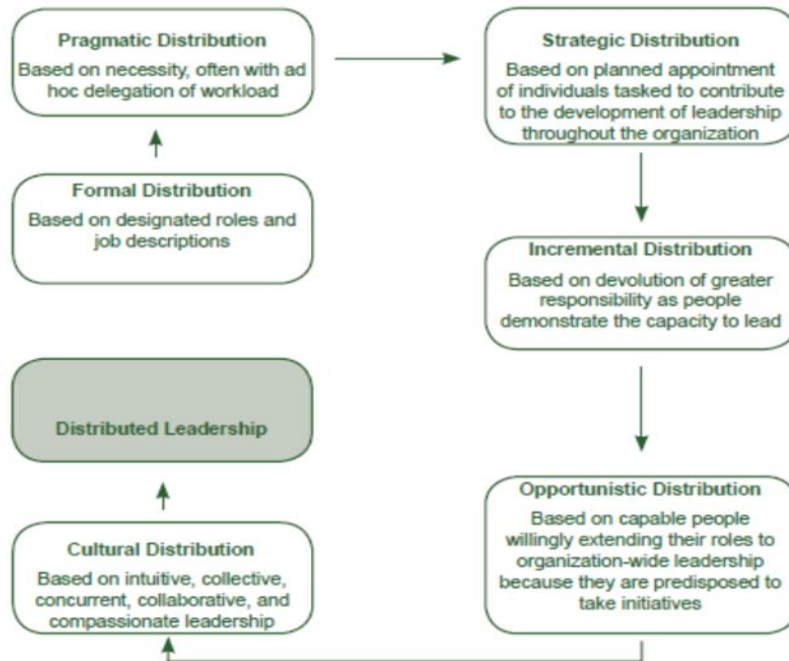

Distributed leadership generally refers to a formal school structure with a tendency to emphasise line management. The diagram below will clarify the three tiers of distribution. The diagram below, developed by ATL (2007:3), shows “the three tiers of distributed leadership”.

Figure 2.2: Three tiers of distributed leadership (ATL, 2007:3)

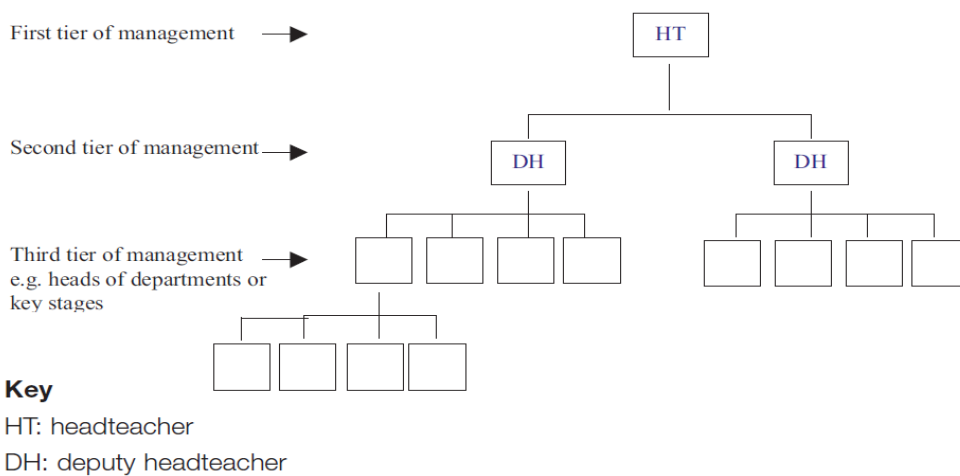

Furthermore, a model was developed to show the distribution of leadership within primary schools. ATL (2007) is of the opinion that the model above is useful in many small to medium-sized primary schools, where a distributed leadership model would be effective to a majority of staff but exclude a small minority. ATL suggests that senior management teams should include other staff in decision-making processes through consultations, taskforces and open meetings when applicable to a given situation. ATL (2007:4) has “developed a diagram that indicates how tasks can be distributed amongst senior leaders and key staff within a primary school”.

Figure 2.3: Distributed management structure within a primary school (ATL, 2007:4)

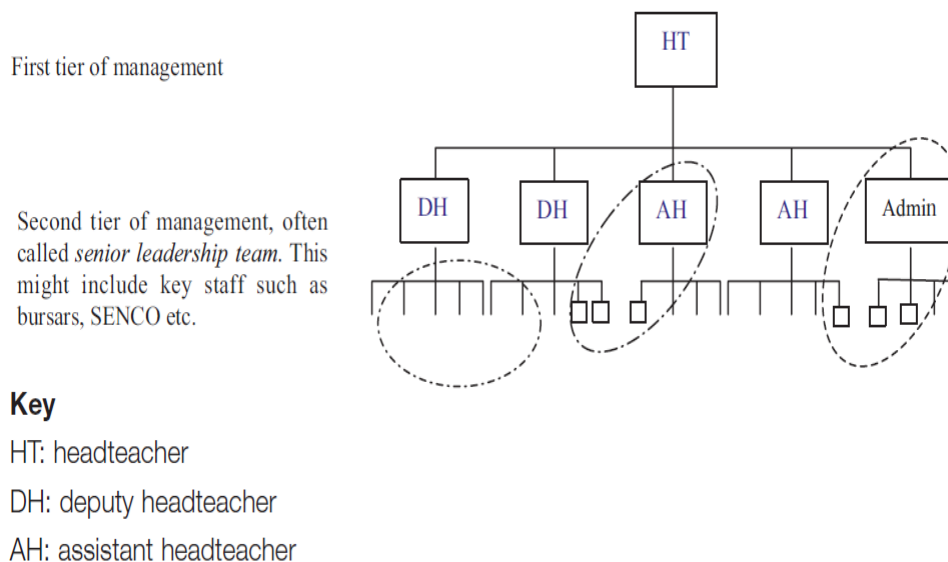

The goal of this study was to clarify structures of distributed leadership used in primary schools. The findings regarding the structures used in South Africa was discussed in chapter five of this study. The link between distributed leadership and democratic leadership will be discussed.

2.5.2 Distributed leadership and democratic leadership

Hatcher (2005) explains that democracy adds to the emergent character of distributed leadership and the notion that everyone, by virtue of his or her human status should play a part in democracy. The recognition of the capabilities of other members of the school to participate implies that the leader trusts his or

her followers and will consequently be comfortable to share power, responsibilities and accountability with the rest of them, as is the case with transformational and servant leaders.

MacBeath (2005:355) views distributed leadership *“as an ability to relinquish one’s role as ultimate decision maker, trusting others to make the right decisions and a belief in the potential and authority of others, listening with the intent to understand, negotiation and persuasion are the levers that allow trust to gain a foothold and leadership to be assumed and shared”*. The purpose of distributed leadership is to connect teachers with the goals and values of the school and freeing the principal of the many responsibilities of administration. In the distributed and democratic model, all teachers collectively assume responsibility for the well-being of the school. Ritchie and Woods (2007) explain that the democratic and distributed leadership model is similar in some ways to the distributed leadership model, which involves distributing responsibility at all administrative levels, working through teams, and engendering collective responsibility. In the distributed leadership model, the principal shares authority and power; teachers take leading roles, assume responsibility, and act independently as individuals or groups. Loeser (2008:3) is of the opinion that *“principals create leadership positions that allow capable and willing teachers to work in a more focused leadership capacity”*.

MacBeath, Oduro and Waterhouse (2004) are of the opinion that the criteria of the distribution and democracy may be formal (with a job description); pragmatic (indicated by necessity); strategic (when an individual's expertise is needed), opportunistic (based on people's preferences); incremental (based on previous performance) and cultural (when it promotes school culture).

Lambert (2005:65) asserts that *“principals need to hand decisions and problem solving back to the teachers, coaching and leading for teacher efficacy while refusing to hold tight to authority and power. Although principals relinquish some control in this model, its strict accountability measures promote good teaching and learning”*. The democratic and distributed leadership model has many benefits for a school. These models advance the efficient implementation of

decisions, maximise the range of knowledge and experience that go into school administration, make all key administrative decisions visible to all, and hold everyone accountable for the effective management of the school, promotes harmonious administration, cultivate the civic goals of schooling, and may likely increase teacher retention. These benefits advance the quality of school life and thereby foster learner development and performance. The role of teachers as leaders and the distribution of leadership will be discussed in the next section.

2.5.3 Distributed leadership and teacher leadership

The Institute for Educational Leadership (2001) has published an article in which there is a discussion of the distribution of leadership as a type of leadership to improve the quality of the school quality and learner performance. In this distribution approach, the leadership functions are shared by multiple members of the school community. Elmore (2000) describes the importance of developing a model of distributed leadership for large-scale improvement of instructional practice and performance and sets five principles that serve as the foundation for a model of distributed leadership, which focuses on large-scale improvement, defining leadership roles, functions of policies, professional, systems, school systems and practice level.

York-Barr and Duke (2004) state that the recognition of teacher leadership comes from new understandings about school development and leadership that suggest active involvement of individuals at all levels and within all domains of school is necessary if change is to take hold.

Educational improvement at the level of teaching involves leadership by teachers in classrooms and with peers. The hope for teacher leadership today is to improve teaching and learning at all schools continuously, resulting in increased achievement for every learner. Danielson (2007) explains that school improvement depends on the active involvement of teacher leaders at the classroom level and beyond. In every school, teacher leaders can find numerous opportunities to extend their influence beyond their own classrooms to the department or teaching team across the school and beyond the school.

Smylie, Conley and Marks (2002) explain that three new approaches to teacher leadership that appear to be more effective than formal leadership roles in promoting school improvement, namely:

- Teacher inquiry in collaborative contexts, which creates new opportunities for teachers to learn and to lead efforts to improve their schools;
- New models of distributive leadership models, which indicate that teachers can and do perform important leadership tasks inside and outside formal positions of authority; and
- Self-managed teams, which promote teacher collaboration so that improve teaching and learning can be improved.

Distributed leadership involves more teachers in leadership roles in the school system to generate innovations with a strong team approach to running a school effectively. The distribution of leadership can have an important effect to enhance teacher engagement and involvement in decision-making. When teachers are involved in decision-making, ideas will be shared amongst leaders.

2.5.4 Distributed leadership and servant leadership

Gordon (2002) explains that dispersed leadership implies leadership that is not necessarily something that an entity does; rather, leadership is something that many people can do so that power can be shared between leaders and followers. Bolden, Gosling, Marturano and Dennison (2003) emphasise that leaders have a duty to serve their followers. This attitude to serve is important for this study because mentoring and coaching is an act of serves from the leader to the follower.

Greenleaf (1970, in Bolden, Gosling, Marturano and Dennison, 2003) is of the opinion that the servant-leader is servant first and starts with the natural feeling that one wants to serve, to serve first. Then conscious choice brings one to aspire to lead. The servant leader is sharply different from the person who is leader first, because of the need to assuage an unusual power drive or to acquire material possessions. For such it will be a later choice to serve – after leadership is

established. The leader-first and the servant-first are two extreme types. Between them, there are shadings and blends that are part of the infinite variety of human nature. In this study, the objective is to ensure that schools are effective for distribution of leadership. The coaching and mentoring models as leadership strategy make it possible that leadership could be distributed and leaders can serve their followers. Leaders need to display certain behaviours when they lead others. The table below, as developed by Katzenbach and Smith (1994) illustrate the critical behaviour that leaders must have to be effective followers.

Table 2.3: Critical key behaviour of leaders to be effective followers (Katzenbach and Smith, 1994)

Key behaviours of Leaders	
Critical behaviour	Leaders as followers
Asking questions	By asking such questions such as "What do you think we should do?" or "How do you suggest we proceed?"
Providing opportunities for others to lead you	Unless the opportunity in question bears a real risk for your personal performance outcome, you are not actually positioning yourself as a follower.
Doing real work in support of others	Contributing "sweat equity" to the efforts and outcomes of other people earns you their appreciation as someone upon whom they can depend,.
Doing real work in support of others	Contributing to the efforts and outcomes of other people earns you their appreciation as someone upon whom they can depend, regardless of the relative hierarchical or functional position each holds.

These key behaviours are essential for the distribution of leadership to succeed in the daily practice because good leaders also need to be good followers in certain situations. According to Katzenbach and Smith (1994, in Bolden, Gosling, Maturin & Dennison, 2003), leaders need to follow certain indicators to be good followers. The table below indicates the characteristics that make leaders need to be followers.

Table 2.4: Indicators for leaders to be good followers (Katzenbach and Smith, 1994)

Indicators for leaders to be good followers	
Leadership indicator	Action of leader who is the follower
Individual performance	As a leader, you must follow another individual, regardless of hierarchy, if: That individual, through experience, skill, and judgment, knows best. That individual's growth demands that you invest more in his or her skill and self-confidence than in your own.
Team performance	As a leader, you must follow the team if: The team's purpose and performance goals demand it. The team, not you, must develop skills and self-confidence. The team's agreed-upon working approach requires you, like all the others, to do real work.
School performance	As a leader, you must follow others, regardless of hierarchy, if: The school's purpose and performance goals demand it. The need for expanding the leadership capacity of others in the school requires it. "Living" the vision and values enjoins you to do so.

The above table is of great importance for this study, because through distribution of leadership the leaders need to be followers as well. Leaders need to accept this because the distributed leadership model could only be effective when leaders accepted the principle of everyone being a leader. Leadership can be more effective when leaders work collaboratively to achieve a common goal. In this study, collaborative approach between leaders and followers ensure that schools are effective in South Africa. This proves that distributed leadership can be used as a leadership strategy to ensure effective schools. This is discussed in the case study in chapter 4.

2.5.5 Distributed leadership and collaborative leadership

According to authors such as Bennis, Benne and Chin (1961), as well as Vroom and Yetton (1973), collaborative leadership in all its forms rests on a fundamental humanistic principle, which can be simply stated as follows: when people who have a stake in a venture are given every chance to participate in the venture, including its implementation, their commitment to the venture will be assured. In this study, the venture is to ensure that schools in South Africa are effective through the distribution of leadership. Glew, O'Leary-Kelley, Friggin and Van Fleet (1995) state that, no matter what form the behavioural change may take through participative management or total quality management, collaborative leadership requires true participation in leadership and decision-making at all levels and in multiple decision processes. The distribution would allow leaders at

all levels to work collaboratively to achieve the maximum goal in education. The maximum goal is that all learners will benefit from effective teaching and learning.

There are three additional principles associated with collaborative leadership that are worth modelling. Firstly, Marshak and Katz (2001) state that collaboration begins any dialogue with a stance of non-judge mental inquiry. In this study, the dialogue was made possible through the coaching and mentoring sessions.

This was discussed in chapter 4 and the empirical study in chapter 5. Habermas (1984) states that collaboration requires submitting one's own ideas and views to the critical scrutiny of others. This was made possible through the coaching and mentoring sessions and is discussed in chapter 5 of this study.

Engestrom, Miettinen, and Punamaki (1998) expand that collaborators need to entertain the view that something new or unique might arise from a mutual inquiry that could reconstruct the participants' view of reality. This is made possible in this study. The researcher conducted thirty interviews and it was clear from the interviews that South African schools are in need of a coaching and mentoring model.

The researcher therefore decided to develop a model on coaching and mentoring to implement in South African schools. This model is discussed in chapter 4 of the study.

Collaborative leadership is also mutual. All members of the school, not just the position leader, are in control of and may speak for the entire school. All members may advocate a point of view that they believe can contribute to the common goal of the school. Although they might be assertive at times, they are equally sensitive to the views and feelings of others and consider their viewpoints equally valid. They thus seek to engage in a public dialogue in which they willingly open their beliefs and values to the scrutiny of others (Raelin, 2001). They also understand the difference between collaborating as pretence versus becoming fully involved. In pretentious involvement, one quickly discovers that all the critical decisions seem to be made when one is absent.

Table 2.5: Levels of collaborative leadership (Raelin, 2006)

Levels	Who leads?	Outcome?
Individual	Coach	Bell (1998) comments that, instead of concentrating on self-expression, one engages in deep listening. A good coach must also be a good listener.
Group	Facilitator	The role of the facilitator in the action learning team is critical to change agency (Raelin, 2006). The facilitator observes the team during learning team meetings and provides feedback both to individual members and to the team as a whole on its interpersonal processes.
School	School consultants	Institutional change can be mobilised by school development (OD) consultants and other change agents who encourage the endorsement of a culture of learning within the school (French, Bell and Zawacki, 2000).

It is clear from the discussion above that leaders need to work collaborative when leadership is distributed. When leaders work collaboratively, leaders need to share ideas to achieve a common goal and in this study, the common objective is to identify leadership strategies that which make schools effective.

2.5.6 Distributed leadership and shared leadership

Elmore (2000) holds the view that distributed leadership is a multiple source of guidance and direction following the contours of expertise in a school, made coherent through a common culture. Andrews and Lewis (2004) expand that distributed leadership is a form of parallel leadership where teacher leaders work with principal leaders in distinctive, yet complementary ways towards goals they all share.

Distributed leadership is a form of shared leadership that is distributed to key stakeholders throughout the school. The researcher here refers to The National Quality Schools Framework in Australia (Department of Education, Science and Training, 2003), which proposes that schools with shared leadership as leadership strategy can create and maintain a shared vision and goals for learner development and learning; empower staff to share leadership for school development that responds to and manages the processes that lead to sustained improvement; create high expectations for learners, teachers and the school, with an unrelenting focus on social, emotional and academic learning outcomes for all learners, support and monitor professional learning through distributed leadership; develop and maintain high-level shared knowledge about curriculum

and innovation through a focus on action, culture building and school-wide learning.

Jameson (2007:10) argues that *“shared leadership implies more than one person exercising some degree of joint leadership and the term does not necessarily include real sharing of power, authority and responsibility at different hierarchical levels. When shared leadership is more advanced developed, it may resemble collaborative leadership”*.

Distributed leadership will be used as a type of shared leadership in this study and will be referred to in the empirical study in chapter 5. ATL (2007) recommends that school leaders aspire to a combined shared leadership with a distributed management model. This does not assume a need for significant changes to management structures, but implies the delegation of management responsibilities to those holding management posts.

The distributed management model fits well with a school structure that is more dynamic; one that utilises temporary teams and task forces with a specific focus that cuts across other hierarchical strata. The strength of this model is that senior leadership teams can respond very quickly to changing circumstances. The distributed leadership model is flexible because the model generates a larger pool of staff that is experienced and confident in managing change. Jameson (2007:11) argues that the distributed leadership model *“goes some way further than shared leadership along the continuum towards fuller group engagement in leadership in specifying distribution of tasks and responsibilities, though not necessarily knowledge, power and authority and it does not imply people necessarily work together to share the knowledge, power and authority of executive leadership”*. The figure below indicates patterns of shared leadership.

Figure 2.4: Patterns of shared leadership (ATL 2007:5)

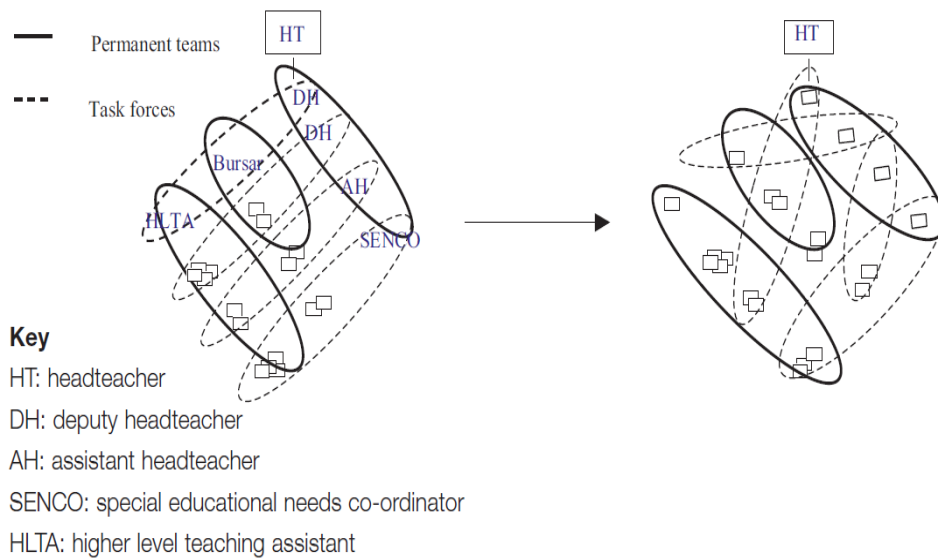

The previous sections clarified the link between distributed leadership, collaborative and shared leadership. The researcher makes a clear assumption that there is a clear link between the three forms of leadership. However, the researcher wants to expand further and identify whether there is a link between distributed leadership and delegated leadership.

2.5.7 Distributed leadership and delegated leadership

Gunter (2005) characterises distributed leadership as authorised distributed leadership where work is distributed from the principal to others within a hierarchical system of relations. This type of leadership can also be clarified as delegated leaders. Harris (2005) is of the opinion that distributed leadership is not delegation. He acknowledges that distributed leadership is a school condition, is promoted not mandated, is inclusive, does not mean everybody leads, and has many school configurations.

Harris (2005) expands that it is important to distinguish between distribution of leadership and delegation of leadership tasks. He holds the view that it is a misunderstanding to assume that distributed leadership means to delegate certain tasks. Distribution of leadership is not delegated leadership. Distribution of leadership describes a process where distributed leadership is the by-product

of shared leadership activities, discussion or dialogue rather than the routine handing out of tasks. Distributed leadership is concerned with two things – the process of leadership of how leadership occurs within the school and leadership activities of how leadership is enhanced and developed within the school.

Spillane, Halverson and Diamond (2001) comments that distributed leadership cannot be delegated. Delegation is a manifestation of power relationships. Expansion of leadership is about empowerment – opportunity, space, support, capacity and growth. Jobs and tasks are delegated (passed down a managerial structure) but leadership is invitational. The researcher will discuss previous study findings in the next section.

2.6 PREVIOUS STUDY FINDINGS ON DISTRIBUTED LEADERSHIP

The researcher only includes five previous study findings in this study, which are relevant to the discussed literature and the objectives of this particular study.

Harris (2005) points out that the connection between leadership generally and school improvement still has to be made, and that there is still no clear empirical link between distributed leadership and improved learner outcomes in her study. In addition to calling for more study into the connection between distributed leadership and learner educational outcomes, Harris surveys the literature on distributed leadership in order to make the theoretical and empirical connections between it and school improvement more explicit. Her survey finds that there is much evidence in theoretical accounts of leadership and individual agency and their relationship to school change to support claims of the effectiveness of distributed leadership. With regard to the empirical case for distributed leadership, Harris finds a fruitful yield in her examination of school improvement literature, where meaningful school improvement is closely associated with strong collegial relationships, a high congruence between the values of principals and teachers, and dispersed sources of leadership and factors which are inherent in distributed leadership models.

Hulpia, DeVos and Van Keer (2009) have investigated the effects of a cooperative leadership team, distributed leadership, participative decision-making, and context variables on teachers' school commitment. Multilevel analyses on data from 1 522 teachers indicate that 9% of the variance in teachers' school commitment are attributable to differences between schools. The analyses reveal that especially the presence of a cooperative leadership team and the amount of leadership support plays a significantly positive key role in predicting teachers' school commitment. In addition, participative decision-making and distribution of the supportive leadership function have a significant positive impact on teachers' school commitment.

Action study by Chamberland (2009) examines the development of distributed leadership practice among a new team of teacher leaders and their principal at an elementary school. Using a qualitative approach, including a series of interviews, observations and journal entries, this study analyses the interactions and changing roles of teacher leaders and their principal as they collaborate to provide school-wide professional development in English Language Development (ELD). The study draws on Spillane's model of distributed leadership practice (2006) as well as activity theory (Vygotsky, 1978; Leont'ev, 1989; Engestrom, 1999). Findings suggest that distributed leadership develops within a school climate of collaboration, where teachers are able to choose meaningful leadership roles connected to teaching and learning. The school principal plays a key role in supporting new leaders by communicating a common purpose, building on a school climate of collaboration, and modelling leadership tools and routines.

A study by Angelle (2010) has examined one middle school where teacher practised distributed leadership daily. Approached from a school perspective, the researcher gathered data from administrator and teacher interviews, school context and learner outcome records.

Findings from this qualitative case study form the basis for a model of distributed leadership. School preconditions include:

- Leadership practice as support for school structure,
- Trust as strengthening school culture, and
- Relationships as the foundation for school affiliation. School constructs of school structure, school culture, and school affiliation, in turn, lead to the school outcomes of (i) efficacy, (ii) increased trust, (iii) job satisfaction, and (iv) teacher intent to stay.

Recent study has focused on the role of the school principal and other site-based leaders in the implementation of professional development initiatives (Pedersen, Yager and Yager, 2010). Teacher, principals and teachers alike, are challenged with higher demands and requirements in preparing our future generations for the 21st century. Professional development for teachers is a key focus in school transformation efforts. School transformation in today's educational system is dependent, in part, by how well teachers work together with their principal and colleagues (Louis, Leithwood, Wahlstrom and Anderson, 2010). Principals play a key role in supporting and encouraging teachers' professional development needs. Successful principals establish the work conditions that enable teachers to be better teachers. The ability to share with others and collaborate for providing instruction that is conducive to enhance learner development is critical, given the many demands that are being put upon the system.

Distributed leadership practice and collaborative learning with professional development initiatives are attributes that could serve school systems well in creating a positive school-wide climate and culture built upon common languages, beliefs, and values that establish a level of excellence in learner preparation. In order to increase the depth of implementation of professional development initiatives focused on pedagogy and improvements in learning of learners, a distributed leadership framework involving multiple learning-centred leaders has been reported to produce positive effects (Sherer, 2004). Only a few studies provide both qualitative and quantitative evidence regarding the impact

of distributed leadership practices on the implementation of professional development initiatives designed to improve school effectiveness and learner achievement (Copeland, 2003; Harris, 2004; Leithwood et al., 2002). Additionally, there has been a call to explore the actual behaviours and influences associated with core leadership practices that occur within distributed leadership frameworks (Louis et al., 2010). This study focuses on providing study results for this call by examining the relationship between distributed leadership, collaboration among teachers and administrators, and school improvements through a professional development initiative.

Researchers have discussed the important role principals play in supporting and encouraging teachers' professional development needs. However, recent studies have suggested that trust by teachers in the school leadership is not essential to transform a school (Louis et al., 2010).

Results from this study indicate that trust in leadership is not only appreciated, but key to the school-wide implementation of professional development initiatives. Indeed, school leaders can have a significant influence on teachers' classroom practices through their efforts to motivate teachers and create workplace settings compatible with instructional practices known to be effective (Louis et al., 2010).

General observations have been made that distributed forms of leadership among a school staff are likely to have significant impact on positive learner achievement (Bell et al., 2003). It is imperative that schools create opportunities for school leaders and school leadership teams to work together, united in school improvement efforts (Spillane, 2006). Several researchers (Elmore, 2000; Miles et al., 2002; Joyce, 2004; Odden et al., 2009) have suggested that effective professional development is linked to the structural feature of collective participation. The professional development should be organised around groups of teachers from a school that would include everyone in the school over time – that is, the entire faculty and other learners. Furthermore, effective sustainability of professional development initiatives has been linked to distributed leadership frameworks and learning-centred leaders within individual schools (Southworth,

1998). When a school's professional learning-centred community engages in school-wide professional development and, at the same time, works toward development of a distinctive identity, it maximises its capacity to enhance outcomes, particularly relative to learner achievement (Crowther et al., 2001). The sustainability of professional development initiatives may be directly increased by increasing the density of leadership opportunities across a school building so that everyone has access to facilitative leaders who can help articulate and analyse the level of implementation. Increasing teachers' involvement in the difficult task of making good decisions and introducing improved practices must be at the heart of school leadership (Louis et al., 2010).

Another interesting finding from the two exemplary schools was the absence of top-down mandates to implement the professional development initiative. The force and motivation for implementation came mostly from the core group of teachers.

However, this study documented that support for teacher empowerment by a central office and its expectations for support at the building level are viewed as essential by teachers in exemplary schools.

This finding is supported by previous study that showed emphasis by a central office on professional development, for quality instruction is key to achieving high-level implementation (Louis et al., 2010).

The researcher explained five previous studies relevant to the current study. Harris (2005) has found theoretical evidence between school change and the effectiveness of distributed leadership. The researcher will discuss the role of distributed leadership as strategy to change leadership through coaching in the next section.

2.7 THE ROLE OF DISTRIBUTED LEADERSHIP AS STRATEGY TO CHANGE LEADERSHIP THROUGH COACHING

Hafford-Letchfield, Leonard, Begum and Chick (2007:171) are of the opinion that *“coaching and mentoring have strong links with action learning because they are focused on problem solving and the continuous process of learning and reflection. Reflective practice is important because it encourages us to take responsibility for ourselves, our learning and for our own actions. It encourages continuing personal and professional development, discourages blame and encourages creativity, problem solving and continuing aspirations to raise quality and standards”*.

According to Hafford-Letchfield, Leonard, Begum and Chick (2007:44), *“improvements in sharing of practice seem enhanced by a group approach to peer support – since work discussion groups involve several practitioners working together over time, the capacity for peer consultation between colleagues develops not only within the group but also outside of the work discussion groups too”*.

One characteristic of teacher leadership is to act as a peer coach. Peer coaching provides a structure for leaders to engage in inquiry, reflect on, and modify their teaching practice and collaborate.

Edwards and Newton (1994b) comment that, after participating in coaching training and implementation of coaching practices, teachers report an increased sense of community in the schools and more teachers talk about teaching and learning. Barth (2001) states that engaging in substantive discussions about teaching and learning develops the personal and interpersonal skills of teachers. The skill development leads to an increased confidence and motivation within teachers to assume leadership roles at their schools.

According to Carson, Tesluk and Marine (2007), managers should encourage each member of the team to demonstrate leadership through personal meetings. During these meetings they should encourage this person to utilise their strengths, provide clarity and offering support and advice. These practices are

effective, because a supportive coaching environment is the principal characteristic of shared leadership. Stone (2007:12 maintains that *“managers master the skill of coaching find that it can boost the performance of workers by making clear to them what they should do and how they should be do it (think instruction), positively reinforce good work (think praise) and find ways to redesign jobs or increase employee contribution (think empowerment or shared leadership)”*.

Blasé and Blasé (1998) sustain that recent efforts to democratise schools have included efforts to empower teachers and professionalise teaching in the area of staff development. Blasé and Blasé have found sustained evidence that effective democratic leaders advocated coaching among teachers for purpose of teacher development. This happened in two ways. Firstly, principals encouraged teachers to become models of one another and served to improve teaching to motivate teachers and providing recognition for exemplary teachers. Teachers reported that modelling good teaching for their colleagues led to greater confidence, motivation and self-esteem. Modelling for colleagues also increased the own reflection and reflectively informed acceptable behaviour towards teaching.

Secondly, for the purpose of professional growth, effective democratic leaders encouraged teachers to visit other schools, to become the learner and to observe classroom programmes. Observing in other classrooms had positive effects on teacher self-esteem, risk taking and guided greater reflection, and reflectively informed behaviour in the classroom.

Distributed leadership is developed through the concepts of democratic, shared and teacher leadership. It is clear from the discussion above that distributed leadership as strategy can change leadership strategies through coaching to improve schools. The role of distributed leadership through mentoring as strategy will be discussed in more detail.

2.8 THE ROLE OF DISTRIBUTED LEADERSHIP AS STRATEGY TO CHANGE LEADERSHIP THROUGH MENTORING

According to Van Kessel (2006), a mentor has a more personal and broader commitment to the individual (including their wellbeing) compared to a coach. Parsloe (1992) emphasises to help and support people to manage their own learning in order to maximise their potential, develop their skills, improve their performance and become the person they want to be. Renshaw (2008:11) stresses that *“mentoring is a development process, including elements of coaching, facilitating and counseling, aimed at sharing knowledge and encouraging individual development. It has a longer-term focus [than coaching] designed to foster personal growth and to help an individual place their creative, personal and professional development in a wider cultural, social and educational context (Why am I doing what I do? How do I perceive my identity? In what ways does this impact on my professional life and work? Where am I going? What determines my long-term goals?)”*.

The role of distributed leadership as strategy to change leadership through mentoring will be discussed. According to Anderson and Shannon (1988), a theoretical understanding of mentoring may be based in the history and etymology of the word. From the myths of ancient Greece, the word describes a nurturing process where a more skilled or more experienced person takes a less skilled or less experienced person under their wing. The mentor becomes a role model, a teacher, who sponsors, encourages, advises and develops a friendship with the protégé. The objective of this on-going relationship is the personal development of the protégé. Darling-Hammond and McLaughlin (1996) sustain that mentors and new teachers working together to improve teaching and learning can serve as model of professional development.

The mentor is one who can open himself to others, who can lead incrementally and who can express care and concern. The mentor is a role model, a nurturer and a caregiver. Five separate functions of the mentor are defined by Shannon and Anderson (1988) broadens their view about mentoring, namely that the teaching function involves modelling, informing, confirming or disconfirming,

prescribing and questioning. The sponsoring function involves protecting, supporting and promoting. The encouraging function involves affirming, inspiring and challenging. The counselling function involves listening, probing, clarifying and advising. The befriending function involves accepting and relating. The activities used to achieve these are demonstration lessons, observations and feedback and support meetings. Roberts (1999) states that participation in a mentoring programme is not only valuable for the novice, but also for the veteran mentor. This also affects the effectiveness of teaching for the mentor and the mentee positively.

The researcher wants to clarify again the point that distributed leadership have elements of different leadership styles, as discussed in chapter 2. MacBeath, Oduro and Waterhouse (2004) have examined definitions for dispersed leadership, collaborative leadership, and democratic leadership and shared leadership. All these definitions have elements of distributed leadership.

Five separate functions of the mentor as clarified by Shannon and Anderson (1988) can be achieved by the distribution of leadership and the mentioned elements could ensure that the identified objective of the study can be achieved.

2.9 CONCLUSION

Chapter 2 gave a literature overview of theoretical framework of the theories and practices of distributed leadership as strategy to ensure effective schools. The chapter addressed the following two study questions:

- What are effective school leadership, leadership strategies and distributed leadership?
- How can distributed support change and improve effective schools?

The concept of school leadership and the theory of school leadership were discussed. The relationship between democratic, teacher, dispersed, collaborative, shared, delegated and distributed leadership was put into context. The chapter discussed the role of distributed leadership as a strategy to change leadership through coaching and mentoring to ensure effective schools. The

chapter also guided the researcher towards the achievement of the major study problem: What is the role of distributed leadership as strategy to ensure effective schools in South Africa?

The strategy of coaching as leadership strategies will consequently be discussed in more detail in the next chapter.

CHAPTER THREE COACHING AS DISTRIBUTIVE LEADERSHIP STRATEGY , ASSURING EFFECTIVE SCHOOLS

3.1 INTRODUCTION

Chapter two explained effective school leadership, leadership strategies and distributive leadership. Furthermore, an exploration was given on how distributive leadership support and improve schools. Babbie and Mouton (2003) are of the opinion that in order for place the study in context of the general body of scientific knowledge relating to the topic it is necessary to undertake a literature review.

Neumans (2003:96) explains that *“a literature review is based on the assumption that knowledge accumulates and that people learn from and build on what others have done. The aim of the literature review is to demonstrate a degree of familiarity with the body of knowledge associate with the study topic; to demonstrate a connection between the various concepts that the study topic consists of and to integrate and summarise what is known about the concepts of the topic”*.

The topic consists of various concepts such as distributed leadership, coaching and mentoring. In order to reach an understanding of the field in which the study is located, each of these concepts have to be considered separately before being assimilated into the specific focus that the study topic defines. Chapter 3 provides a discussion on coaching as distributive leadership strategies in effective schools. The major study problem is: What is the role of distributive leadership as strategy to assure effective schools?

In Chapter 2, the concept of distributed leadership was discussed in detail (par. 2.5; 2.5.1; 2.5.2; 2.5.3; 2.5.4; 2.5.5, 2.5.6 and 2.5.7). Chapter 3 begins with a clarification of the concept of “coaching” in relation to this study exercise. The relation between coaching models are explored to culminate into distributed leadership strategies, as experienced in a variety of leadership styles, such as

democratic leadership, teacher leadership, collaborative leadership and shared leadership. Coaching as distributive leadership strategy leads to a discussion about strategies, which ensure effective schools in the school context. Finally, the advantages and limitations of coaching are explored from both a generic stance of leadership in schools and with specific reference to the influence of coaching and mentoring to enhance the distribution of leadership in effective schools in South Africa. The researcher will address the sub-question in Chapter 3: How has coaching been used as a successful and effective distributed leadership strategy? The researcher also achieved the objective: “To investigate how coaching were used as an effective and successful distributed leadership strategy” in chapter 3.

There are many strategies, which can be used to distribute leadership within schools such as mentoring, coaching and 360-degree self-assessment of leaders. However, in this study the researcher decided to focus only on coaching as strategy to distribute leadership within schools. Clutterbuck (2001) explains that coaching is primarily a short-term intervention aimed at performance improvement on developing a particular competence. The competence of teaching staff will ensure that schools are more effective. This will also proof that the researcher achieved the objective of the study: - “What is the role of distributive leadership as strategy to ensure effective schools in South Africa?”

The researcher will discuss the collaborative nature of coaching as a seven-stage pattern that links to the strategy of distributed leadership in the next section.

3.2 THE COLLABORATIVE NATURE OF COACHING AS A SEVEN-STAGE PATTERN THAT LINKS TO DISTRIBUTED LEADERSHIP STRATEGY

Coaching is a strategy, which leaders can use to improve the standard of teaching. Parsloe (1999) explains that coaching is a process that enables learning and development to occur and thus improve individual performance of identified teachers.

Clutterbuck (2001) adds that coaching is effective when:

- It focus on skills and performance;
- It is the role of the line manager to coach,
- It addresses short-term needs and
- Feedback and discussion is primarily explicit.

Cope (2004:1) described collaborative coaching “as a process of transference – whereby one person with prior knowledge or experience can impart his wisdom with a goal to optimise performance as a process of discovering where they help another person to reach full potential and to be capable to complete a task or a job at hand”. The collaborative nature of the seven-stage framework is important because the two drivers of coaching, “help someone” and “help themselves”, come together at the midpoint on the coaching continuum. Figure 3.1 will show the nature of the collaborative coaching (Cope, 2004:3)

Figure 3.1 Collaborative nature of the 7Cs framework (Cope, 2004:3)

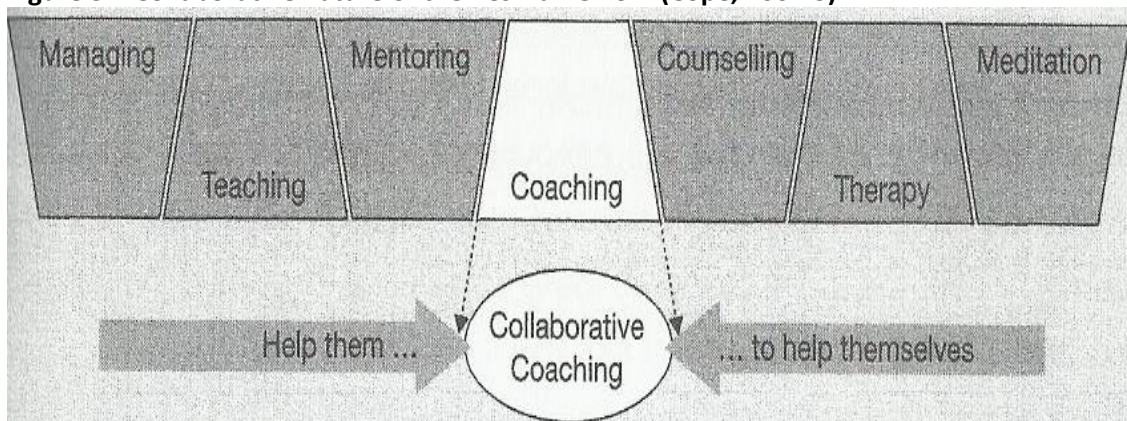

The framework is a seven-stage wheel that follows the themes shown in Figure 3.2 (Collaborative coaching, as developed by Cope, 2004:27).

Figure 3.2: Seven-stage coaching wheel frame (Cope, 2004:27)

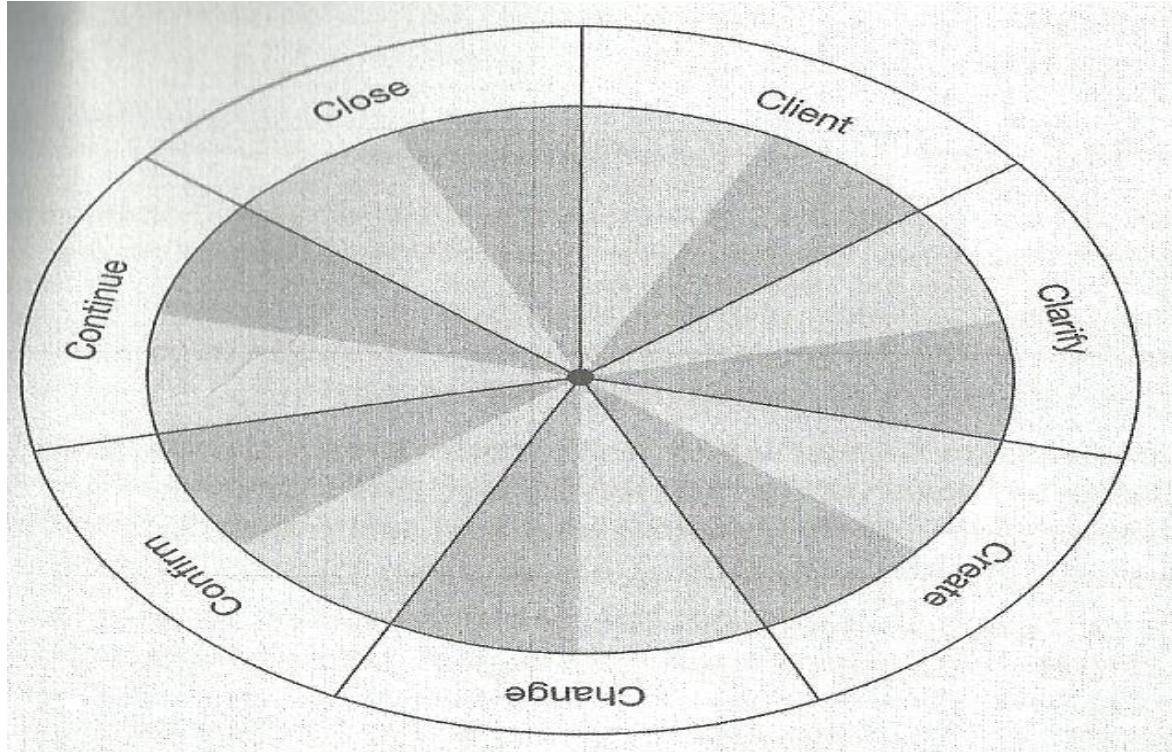

Copeland (2004:26) notes that *“it is important to stress from the outset this is a framework, not a methodology. It is not designed to be a regimented process that needs to be followed religiously. The idea is to offer a pattern that people can follow as and when appropriate. So the coach and the client make the choices of where to go on the journey and what tools to use”*.

The researcher will discuss next how the seven-stage collaborative coaching frame can be linked to the distribution of leadership. Table 3.1 will describe and analyse the link between a seven-stage collaborative coaching frame and distributed leadership. The acronym C1-7 can be used to describe the seven stages of the collaborative coaching frame.

Table 3.1: The seven Cs of coaching (Copeland, 2004)

The use of the 7Cs as a coaching frame	Coaches can distribute leadership by means of
The coach and the client will discuss what has happened, what is happening, and what the client (C1) wants to happen.	Ritchie and Woods (2007) explain that the democratic and distributed leadership model is similar in some ways to the distributed leadership model, which involves distributing responsibility at all administrative levels, working through teams, and engendering collective responsibility (par 2.5.4).
The coach needs to clarify (C2) what the client wants by means of coaching sessions.	MacBeath, Oduro and Waterhouse (2004) are of the opinion that the criteria of the distribution and democracy may be formal (with a job description), pragmatic (indicated by necessity), strategic (when an individual's expertise is needed), opportunistic (based on people's preferences), incremental (based on previous performance) and cultural (when it promotes school culture) (par 2.5.4).
The create (C3) framework helps the client to look for diverse options and then helps manage the solution process	Glew, O'Leary-Kelley, Friggin and Van Fleet (1995) state that, no matter what form the behavioural change may take by means of participative management, total quality management, or school learning – collaborative leadership requires true participation in leadership and decision-making at all levels and in multiple decision processes. The distribution would allow leaders at all levels to work collaboratively to achieve the maximum goal in education (par 2.6).
Copeland (2004) explains the change (C4) framework addresses the issues around mobilisation in the coaching partnership and explores the level of force.	Professional development for teachers is a key focus in school transformation efforts. School transformation in today's educational system is dependent, in part, on well teachers work together with their principal and colleagues (Louis, Leithwood, Wahlstrom and Anderson, 2010) (par 2.6).
The idea of "Cockpit confirmation" (C5) is an effective tool for the client to monitor own progress and measure level of achievement (Copeland, 2004).	Distributed leadership is a form of shared leadership that is distributed to key stakeholders throughout the school. The researcher here refers to The National Quality Schools Framework in Australia (Department of Education, Science and Training, 2003), which proposes that schools with shared leadership as leadership strategy can support and monitor professional learning by means of distributed leadership and develop and maintain high-level shared knowledge about curriculum and instruction (par2.5.6).
Continue (C6): Copeland (2004) is of the opinion that the coach and the client need to identify things that will bring about decay in the change and those things that will help it to last.	Jameson (2007:11) argues that the distributed leadership model include distribution of tasks and responsibilities, power and authority (par 2.5.6 and fig 2.4).
Close (C7). The coach needs to assure that the outcome has been delivered and that learning has been gleaned along the way, both of which will have a profound impact on the sustainability of change (Copeland, 2004).	Lambert (2005:65) asserts that principals need to hand decisions and problem-solving back to the teachers, coaching and leading for teacher efficacy while refusing to hold on tightly to authority and power. Although principals relinquish some control in this model, its strict accountability measures promote good teaching and learning (par 2.5.2).

The role of the coach is to help the client to make the right choices. There is a range of coaching models. The researcher shall discuss a few of the coaching models and link the coaching model to the distribution of leadership. The researcher shall then explain which coaching model is the most effective to use in South African schools.

3.3 MODELS OF COACHING AS DISTRIBUTIVE LEADERSHIP STRATEGY

Hargrove (2003) is of the opinion that learning is inherent within the coaching process. Numerous coaching texts and studies refer to the implicit nature of learning in coaching, which paves the way for the achievement of goals and manifestation of change. In this particular study, the change is role of coaching as a distributed leadership strategy to assure effective schools in South Africa.

The creation of a culture of coaching is significant for school improvement initiatives. Creasy and Paterson (2005:4) explain that *“growing out of a business model with a focus on empowering employees to reach more aspirational targets, coaching now stands as an important part of the collaborative learning strategies within many development opportunities in education ranging from initial teacher training to headship preparation and leadership development”*.

Curee (2005) identified ten strategies to assure effective coaching. The researcher linked these ten strategies with distributed leadership strategies as discussed in Chapter 2 (Table 3.1, effective coaching). This will also support the researcher to assure that there is a clear link between the study topic and the content of the study. The researcher wants to emphasis again: The role of distributed leadership with a comparative analysis within selected South African schools. This will be discussed in more detail in Chapter 4 (Case study with selected South African schools).

Table 3.2: Effective coaching (Curee, 2005)

Effective coaching involves.....	Distributed leadership strategies to assure effective coaching as leadership strategy
A learning conversation by means of a professional dialogue rooted in evidence	Mac Beath (2005) views democratic leadership as an opportunity where leaders have to listen with the intent to understand (par 2.5.2).
A thoughtful relationship based on trust and sensitivity	Lambert (2005) states principals need to hand decisions and problem solving back to teachers and coaches (par 2.5.2). This is an important characteristic of democratic leadership.
A learning agreement establishing confidence in boundaries and ground rules	An important characteristic of shared leadership is to support; change and monitor professional learning by means of distributed leadership (par 2.5.6).
Combining support from fellow professional learners and specialists	Shared leadership is to empower staff to share leadership from school development that lead to sustained improvement (par 2.5.6).
Grown self-direction by increasing responsibility for own development	Collaboration requires one's own ideas and views to the critical scrutiny of others (par 2.5.5).
Setting challenging goals linked to school priorities	Democracy is based on previous performance of the culture of the school (par 2.5.2).
Understanding different approaches and their underpinning theory	Smylie, Conley and Marks (2002) explain that teacher leadership appears through teacher enquiry in collaborative context, which creates new opportunities for teachers to learn and to lead efforts to improve their schools (par 2.5.3).
Acknowledging benefits to those coaching recognising symbolic learning	Engestrom (1998) explains that, by means of collaborative leadership, something new might arise from a mutual inquiry that could reconstruct the participant views (par 2.5.5).

3.4 COACHING IN EDUCATIONAL SETTINGS

Grant's (2003b) stresses that cognitive coaching is frequently used to assist teachers in delving into the thinking behind their practices. Authors such as Costa and Garmston (1994) add that it encourages self-monitoring, self-analysis and self-evaluation of teaching practices in order to maximise learning. It is a form of coaching which is similar in its emphasis on reflection, self-monitoring and self-evaluation, but does not exhibit the same commitment to goal achievement and focused action.

Peer coaching is also prevalent in formal education settings in two forms such as expert coaching and reciprocal coaching. Zeus and Skiffington (2002) explain that expert coaching involves feedback, support, alternatives and suggestions, while reciprocal coaching involves observation, feedback, support and natural learning. There are a few coaching models that can be used to make schools more effective. The first coaching model to discuss is the GROW coaching model and the link of this coaching model to distribute leadership within schools.

3.4.1 The GROW coaching model as distributed leadership strategy

Whitmore (2002:54) developed a “*seminal model of the coaching process based on the acronym GROW (goal, reality, options and way forward)*”. Table 3.3 will link the GROW coaching and distributed leadership as leadership strategy in more detail.

Table 3.3: The GROW model of coaching (Whitmore, 2002)

Strategy	Coaching Process	Coaches can distribute leadership by means of.....
Goal	Setting a goal for each session as well for the short and long term	Collective leadership takes place when members in a group work together towards a common purpose and goal (par 2.4).
Reality	Checking and explaining the current situation	In the democratic leadership model, all teachers collectively assume responsibility for the well-being of the school (par 2.5.2).
Options	Alternative strategies options	ATL (2007) suggest that distributed leadership is effective by means of consultations, task focus and open meetings, where applicable advice is given to certain situations (par 2.5.1).
What	What is done, when is it done and by whom is it done	Three tiers of distributed leadership (ATL, 2007). Tier 1 is the principal, tier 2 is the senior leadership team and tier 3 is heads of departments (par 2.5.1).

The implementation of the GROW coaching model can support school leaders to distribute leadership by means of the GROW coaching model as leadership strategy to assure effective schools in South Africa. The GROW coaching model can support leaders to set goals, evaluate current situations, identify different strategies to assure effectiveness and evaluate successes achieved by team leaders and team members.

The second model, which leaders can use as a coaching model, is the STRIDE model.

3.4.2 The STRIDE coaching model as distributed leadership strategy

The stride model was developed by Thomas (2009). Table 3.4 will explain the STRIDE model in more detail. Thomas (2009) developed the model based on strengths, targets, real situations, ideas, decisions and evaluations. Leaders can use the STRIDE model as a coaching and leadership strategy to assure distribution of leadership. Table 3.3 will analyse the link between distributed leadership and coaching as a leadership strategy by means of the STRIDE model. This will assure that the researcher also achieves the objective: - *“to investigate how distributed leadership can be used as an effective and successful leadership strategy”* (par 1.3).

Table 3.4: The STRIDE model of coaching (Thomas, 2009)

Strategy	Coaching Process	Coaches can distribute leadership by means of
Strengths	Ask yourself at each step. What strengths do I have that will help me right now.	Distribution by means of shared responsibility to achieve mission, vision and goals (Elmore, 2000) (par 1.2.2).
Target	What will even better performance be like?	Teacher leadership supports teachers to understand that changes are needed and that teamwork is needed to drive the school towards whole-school improvement (par 1.2.2).
Real situation	What is getting in my way?	A process which involves collaborative relationship and actions grounded in shared value of people who work together to encounter positive change (Aditja, 1997) (par 1.2.2).
Ideas	How might I improve this situation?	Mac Beath (2005) explains that distributed leadership creates opportunities to listen with the intent to understand and to negotiate so that changes could be shared, amongst others (par 2.5.2).
Decisions	What further support do I need?	Lambert (2005) asserts principles need to hand decisions and problem solving back to teachers, coaching and lead teachers, while refusing to hold tight to authority and power (par 2.5.2).
Evaluation	On a one to ten scale how committed am I to this action?	Smylie, Conley and Marks (2002) are of the opinion that teacher leadership promotes teacher collaboration so that teaching and learning can be improved (par 2.5.3).

The implementation of the STRIDE coaching model can support school leaders to distribute leadership and assure effective schools in South Africa. The STRIDE coaching model can support leaders to evaluate strengths within teams; set targets to improve performance within teams; identify problems that hamper progression within teams; sharing ideas to improve performance of teams; and clarify who can support teams to improve performance even more.

The third coaching model that leaders can use as a coaching model is the OSCAR coaching model.

3.4.3 The OSCAR coaching model as distributive leadership strategy

Gilbert and Whittleworth (2009) explain that the OSCAR coaching model is quite a simply framework and provides a simple structure that helps to keep the coaching process focused, structure and time effective. The OSCAR coaching model works well for managers because it is simple, it is easy to understand, it is common sense and managers are already using it without calling it OSCAR.

Managers and leaders can use the OSCAR coaching model as leadership strategy to assure distribution of leadership. Table 3.4 will describe the link between distributed leadership and coaching as leadership strategy by means of the OSCAR model. This will assure that the researcher achieved also achieves the objective: *“to investigate how distributed leadership can be used as an effective and successful leadership strategy”*(par 1.4).

Table 3.5: The OSCAR coaching model (Gibert and Whittleworth, 2009)

Strategy Coaching Strategies	Coaches can distribute leadership by means of
<p>Outcome: Gibert and Whittleworth (2009) explains that managers have to plan for success. This involves thinking about what success would look like. This is sometimes referred to as vision. Managers with well-formed outcomes achieve much more than those without clear outcomes.</p>	<p>There is a link between collaborative leadership and outcomes of the OSCAR model, as discussed by Gilbert and Whittleworth (2009). Glew, O'Leary-Kelley, Friggin and Van Fleet (1995) state that, no matter what form the behavioural change may take by means of participative management, total quality management, or school learning – collaborative leadership requires true participation in leadership and decision-making at all levels and in multiple decision processes. The distribution would allow leaders at all levels to work collaboratively to achieve the maximum goal in education. The maximum goal is that all learners will benefit from effective teaching and learning (par 2.5.5).</p>
<p>Situation: Gilbert and Whittleworth (2009:41-42) are of the opinion that managers need a grip on the situation. They need to know what is going on in their team. They need to know what is happening in the school. They need to know the facts. Managers come face to face with difficult situations on a daily basis To understand the situation in their team in full, they will have to listen to the team members.</p>	<p>Smylie, Conley and Marks (2002) explain that three new approaches to teacher leadership that appear to be more effective than formal leadership roles in promoting school improvement, namely teacher inquiry in collaborative contexts, which creates new opportunities for teachers to learn and to lead efforts to improve their schools; new models of distributive leadership models, which indicate that teachers can and do perform important leadership tasks inside and outside formal positions of authority; and self-managed teams, which promote teacher collaboration so that improve teaching and learning can be improved (par 2.5.3).</p>
<p>Choices and consequences: Gilbert and Whittleworth (2009:42-43) explains that managers are decision makers. They make choices by selecting the best possible choice from the list of choices available to them. The process of creating a list of choices is often referred to as brainstorming.</p>	<p>The researcher here refers to The National Quality Schools Framework in Australia (Department of Education, Science and Training, 2003), which proposes that schools with shared leadership as leadership strategy create and maintain a shared vision and goal for learner development and learning and empower staff to share leadership for school development that responds to processes that lead to sustained improvement (par 2.5.6).</p>
<p>Action: Gilbert Whittleworth (2009:43-44) managers need to be action planners. The action plan coordinates the team's efforts on a daily basis. Team members need to know what is expected of them, what they are expected to do and when they are expected to do it. Successful teams are proactive and action is essential. Action has to follow a process of establishing a clear outcome, a clear situation and having made the best possible choice to achieve the outcome.</p>	<p>Distributed leadership is a form of shared leadership that is distributed to key stakeholders throughout the school. The researcher here refers to The National Quality Schools Framework in Australia (Department of Education, Science and Training, 2003), which proposes that schools with shared leadership as leadership strategy develop and maintain high-level shared knowledge about curriculum and instruction; and initiate innovation through a focus on action, culture building and school-wide learning (par 2.5.6).</p>
<p>Review: Gilbert and Whittleworth (2009:44) elaborate that managers need to stop and notice what is going on. They need to review performance. Managers attend meetings and all meetings are reviewed.</p>	<p>Engestrom, Miettinen, and Punamaki (1998) expand that collaborators need to entertain the view that something new or unique might arise from a mutual inquiry that could reconstruct the participants' view of reality (par 2.5.5).</p>

Managers and leaders can also implement the OSCAR coaching model to distribute leadership and assure effective schools in South Africa. The OSCAR coaching model can support leaders to do action planning to assure success and achievement of outcomes; monitor outcomes and evaluate whether the outcomes were achieved; lead and manage their teams to achieve outcomes; make decisions to solve problems effectively within teams and review all actions; and evaluate performance and effectiveness of teams.

The fourth coaching model, which leaders can use as a coaching model, is the executive coaching model.

3.4.4 The strategic executive coaching model as distributive leadership strategy

Authors such as Kampa-Kokesch and White (2002) are of the opinion that executive coaching is a formal, ongoing relationship between an individual or team with managerial authority and responsibility in an school, and a consultant who possesses knowledge of behaviour change and school functioning. Authors such as Kampa-Kokesch and Anderson (2007) and Killburg (2007a) add that the goal of this relationship is to create measurable behavioural change in the individual or collection of individuals (the team), resulting in increased individual and school performance, where the relationship between individual or team and consultant facilitates this change by or through giving direct behaviourally based feedback, creating opportunities for change and demanding accountability.

The executive coaching model is developed in such a way that managers can be coached to enhance their own performance. Table 3.5 will explore the link between distributed leadership and coaching as leadership strategy by means of the strategic executive coaching model.

This will assure that more evidence was collected to achieve the objective: To investigate how distributed leadership can be used as an effective and successful leadership strategy (par 1.3).

Table 3.6: The strategic executive coaching model (Freas, 2000)

Coaching Process	Coaches can distribute leadership by means of
<p>Step 1: Careful contracting</p> <p>A great deal of honest communication and feedback will set the parameters of the executive coaching process. The objectives of the 'contracting dialogue' should include the following: (1) identified success factors for a specific executive's (or team's) current and potential role; (2) agreement on confidentiality boundaries; (3) identification of specific expected business results; and (4) confirmation that the 'chemistry' is right to build trust and rapport (Freas, 2000).</p>	Danielson (2007) explains that school improvement depends on the active involvement of teacher leaders at classroom level and beyond. In every school, teacher leaders can find numerous opportunities to extend their influence beyond their own classrooms to the department or teaching team across the school and beyond the school (par 2.5.3).
<p>Step 2: Comprehensive assessment</p> <p>The ultimate value of the assessment process is that the results clearly illustrate areas of strength as well as those requiring attention</p>	No evidence was found in the literature study conducted in Chapter 2.
<p>Step3: Feedback dialogue and action planning</p> <p>The aim is to work within a framework that directs feedback towards the key objectives of the business (Freas, 2000). The action plan must focus on behaviours that contribute to specific business outcomes</p>	Collaborative leadership might be assertive at times, they are equally sensitive to the views and feelings of others and consider their viewpoints equally valid. (Raelin, 2001) (par 2.5.5).
<p>Step 4: Active learning</p> <p>Special developmental courses and team activities are often recommended to support the executive coaching process. The coaching process is usually supported by a series of monthly meetings between the coach, executive and key stakeholders. These dialogues help to assure that the milestones are being met, the ground rules are being followed and the coaching process continues to be focused on the school's business needs (Freas, 2000).</p>	Principals play a key role in supporting and encouraging teachers' professional development needs. Successful principals establish the work conditions that enable teachers to be better teachers. The ability to share with others and collaborate for providing instruction that is conducive to enhancing learner development is critical, given the many demands on the system (par 2.6).
<p>Step 5: Reviewing and sustaining success</p> <p>Follow-up is a critical success indicator of the entire executive coaching process. In addition, to assure overall quality, assessment of the coach is essential (Freas, 2000).</p>	MacBeath, Oduro and Waterhouse (2004) are of the opinion that the criteria of the distribution and democracy may be formal (with a job description); pragmatic (indicated by necessity); strategic (when an individual's expertise is needed), opportunistic (based on people's preferences); incremental (based on previous performance) and cultural (when it promotes school culture) (par 2.5.2).

The Strategic Executive Coaching Model is a typical example of a process model, which describes the coaching process by means of a number of steps. The fifth coaching model that leaders can use as a coaching model is the team coaching model.

3.4.5 The team coaching model as distributive leadership strategy

Team dynamics in schools can play an important part in triggering both ineffective and destructive behaviour (Wegge, 2003). The ultimate goal of team coaching is assisting a team to reach its maximum potential (Hackman & Wageman, 2005). Significant changes usually lead to an increase in anxiety, especially when the outcome of the project is uncertain (Edmondson, 2002). Teams are part of a complex system and therefore influenced by many environmental and external forces (Gladstein, 1984). Hackman (1987) stresses the benefit of effective teams contributing to their schools. There is a link between distributed leadership and team coaching. MacBeath (2005:355) views distributed leadership as “an ability to relinquish one’s role as ultimate decision maker, trusting others to make the right decisions and a belief in the potential and authority of others, listening with the intent to understand. The purpose of distributed leadership is to connect teachers with the goals and values of the school and freeing the principal of the many responsibilities of administration. In the distributed and democratic model, all teachers collectively assume responsibility for the well-being of the school”.

Hackman and Wageman (2005) specifically look at three aspects of team interactions that they identified as contributing to teamwork effectiveness: joint effort towards the task, deployed suitability of strategies teams used in relation to the task and the expertise of team members. According to Scholl (2005), cooperation, as opposed to competition, is a requirement for successful teamwork, and Pearsall and Ellis (2006) recommend that schools pay heed to team design and understand the workflow within a team network and therefore select corresponding staff on board.

Jameson (2007:10) argues that: “*shared leadership implies more than one person exercising some degree of joint leadership and the term does not necessarily include real sharing of power, authority and responsibility at different hierarchical levels. When shared leadership is more advanced and developed, it may resemble collaborative leadership*” (par. 2.5.5).

Tse and Dasborough (2008), in their study of interpersonal relationships between team members, state that people are more willing to share and centralise information, to come up with ideas and provide necessary feedback within a cohesive team. Hilsenbeck (2006) emphasises the fact that distorted perceptions by team members will almost inevitably lead to poor decisions. He urges coaches and practitioners to make room for discussions, setting up subgroups, determining a person functioning as devil's advocate. With regard to team coaching, Hackman (1987) stresses a framework that includes appropriate group task assignment; competence and authority of the team; the perception by the team itself and outsiders as an acknowledged team; a team-supporting school environment; and coaching that concentrates on prominent changes in task performance processes. Elmore (2000) describes the importance of developing a model of distributed leadership for large-scale improvement of instructional practice and performance and sets five principles that serve as the foundation for a model of distributed leadership, which focuses on large-scale improvement, defining leadership roles, functions of policies, professional, systems, school systems and practice level. York-Barr and Duke (2004) state that the recognition of teacher leadership comes from new understandings about school development and leadership that suggests active involvement of individuals at all levels and within all domains of an school is necessary if change is to take hold (par. 2.5.3).

Whitmore (2002) recommends that team coaching follows the same guidelines as coaching individuals, so that the objective should be to accentuate not only mutual team awareness, but also to heighten individuals' perception.

Jameson (2007:11) argues that the distributed leadership model goes some way further than *"shared leadership along the continuum towards fuller group engagement in leadership in specifying distribution of tasks and responsibilities, though not necessarily knowledge, power and authority and it does not imply people necessarily work together to share the knowledge, power and authority of executive leadership"*.

The above discussions prove that there is a clear link between distributed leadership and coaching as a leadership strategy. The researcher explains how the five coaching models can be utilised as leadership strategies to assure distribution of leadership. The researcher achieved the objective: To investigate how distributed leadership can be used as an effective and successful leadership strategy and the sub-question: How distributed leadership can be used as an effective and successful leadership strategy. A comparison between the coaching models and distributed leadership strategies will be discussed next.

3.5 THE ROLE OF COACHES TO DISTRIBUTE LEADERSHIP THROUGH COACHING TO ASSURE EFFECTIVE SCHOOLS

In Chapter 2 the researcher discussed the link between democratic leadership, teacher leadership, servant leadership, collaborative leadership, shared leadership, delegated leadership and distributed leadership. The researcher drew the conclusion that there is a clear link between the different leadership styles and distributed leadership. The researcher wants to compare the different leadership styles and the different coaching models to identify which coaching models would be the best for South African Schools.

3.5.1 The role of coaches to distribute leadership by means of the GROW coaching model

The role of coaches to distribute leadership by means of the GROW coaching model to assure effective schools will be discussed in Table 3.7.

Table 3.7: The GROW coaching model to distribute leadership (Whitmore, 2002)

The GROW coaching model to distribute leadership	
GROW coaching model strategies	Coaches can distribute leadership by means of Strategies
Goal	Collaborative leadership (par 2.4 and 3.4.1)
Reality	Democratic leadership (par 2.5.2 and 3.4.1)
Options	Teacher leadership (par 2.5.1 and 3.4.1)
What	Teacher leadership (figure 2.2 and par 3.4.1)

The researcher wants to make the assumption that coaches who apply the GROW coaching model as coaching strategy can distribute leadership by means of collaborative, democratic and teacher leadership. There is enough evidence that coaching can assure effective schools by using the GROW model to assure effective schools. Also, this assures that the researcher will achieve the objective (to investigate how distributive leadership can be used as an effective and successful leadership strategy, chapter one). The use of the STRIDE coaching model as leadership strategy will be analysed next.

3.5.2 The role of coaches to distribute leadership by means of the STRIDE coaching model

Table 3.8 will clarify the role of coaches to distribute leadership by means of the STRIDE coaching model to assure effective school.

Table 3.8: The STRIDE coaching model to distribute leadership (Thomas, 2009)

The STRIDE coaching model to distribute leadership	
STRIDE coaching model strategies	Coaches can distribute leadership by means of Strategies
Strengths	Shared leadership (par 1.2.2 and 3.4.2)
Target	Teacher leadership (par 1.2.2 and 3.4.2)
Real situation	Collaborative leadership (par 1.2.2)
Ideas	Shared leadership (par 2.5.2)
Decisions	Teacher leadership (par 2.5.2)
Evaluation	Collaborative leadership (par 2.5.3)

There are enough evidence that a coach can distribute leadership by means of shared, teacher and collaborative leadership. The researcher wants to assume that leadership can be distributed by means of the STRIDE coaching model.

3.5.3 The role of coaches to distribute leadership by means of OSCAR coaching model

Leadership can be distributed by means of the OSCAR coaching model and this can assure effective schools. Table 3.9 will give a clear indication of how leadership can be distributed.

Table 3.9: The OSCAR coaching model to distribute leadership (Gilbrt and Whittlewoth, 2009)

The OSCAR coaching model to distribute leadership	
OSCAR coaching model strategies	Coaches can distribute leadership by means of Strategies
Outcome	Collaborative leadership (par 2.5.5, 3.4.3 and table 3.4)
Situation	Teacher leadership (par 2.5.3, 3.4.3 and table 3.4)
Choices and consequences	Shared leadership (par 2.5.6, 3.4.3 and table 3.4)
Action	Shared leadership (par. 2.5.6, , 3.4.3 and table 3.4)
Review	Collaborative leadership (par 2.5.5, ,3.4.3 and table 3.4)

Evidence from Table 3.9 gives a clear indication that coaches can distribute leadership by means of collaborative, teacher and shared leadership. Furthermore, it proof that leaders can distribute leadership tasks and responsibilities to make schools more effective.

3.5.4 The role of coaches to distribute leadership by means of the strategic executive coaching model

Leadership can be distributed by means of the strategic executive coaching model. Table 3.10 will clarify how leadership can be distributed by utilising the strategic executive coaching model.

Table 3.10: The role of coaches to distribute leadership by means of the strategic executive coaching model (Fraes, 2000)

The Strategic executive coaching model to distribute leadership	
Strategic coaching model strategies	Coaches can distribute leadership by means of Strategies
Careful contracting	Teacher leadership (par 2.5.3 and 3.4.4)
Comprehensive assessment	No evidence in the literature study
Feedback dialogue	Collaborative leadership (par 2.5.5 and 3.4.4)
Active learning	Teacher leadership (par 2.6 and 3.4.4)
Reviewing and sustaining success	Democratic leadership (par 2.5.2 and 3.4.4)

Effective coaches can distribute leadership by means of teacher, collaborative and democratic leadership. The role of leaders to distribute leadership by means of the team coaching model to assure effective schools will be clarified next.

3.5.5 The role of coaches to distribute leadership by means of the team coaching model

Leadership can be distributed by means of the team coaching model and this can assure effective schools. Table 3.11 will give a clear indication of how leadership can be distributed.

Table 3.11: The Team coaching model to distribute leadership (Hackman and Wageman, 2005)

The Team coaching model to distribute leadership	
Team coaching model strategies	Coaches can distribute leadership by means of Strategies
Reaching maximum potential	Team coaching (par 3.4.5)
Joint effort to complete a task	
Share information and provide feedback	
Focus on team actions	

A combination of democratic, teacher and shared leadership can assure that leaders can distribute by means of the team coaching model. The implementation of the OSCAR coaching model as leadership strategy to ensure more effective schools in South Africa will be discussed in the next section.

3.6 THE IMPLEMENTATION OF THE OSCAR COACHING MODEL AS LEADERSHIP STRATEGY TO ASSURE MORE EFFECTIVE MEETINGS IN SOUTH AFRICA SCHOOLS

Leaders spend a large proportion of their daily work life in meetings. Many meetings are badly run and time-consuming. It is important that leaders need to make the most of their meetings. The researcher wants to assume that using the OSCAR coaching model to facilitate meetings and to coach groups could ensure more effective schools in South Africa.

Gilbert and Whittleworth (2009:96) explain that the benefits of well-managed meetings will: *“save time; improve motivation; create opportunities for better decision making; resolve problems quicker; build more stronger and more productive working relationships; establish meetings that involve all the team; encourage participation and responsibility of all team members; ensure that there are less meetings where the leader tells, instructs and make all the decisions”*.

Gilbert and Whittlewoth (2009) add that any meeting, which involves discussion, problem solving and action planning, creates an opportunity for group coaching. Gilbert and Whittleworth (2009:96) add that *“group coaching involves leadership without taking the reins, focusing on asking questions instead of telling and listening and building consensus”*.

The biggest problem with meetings is the fact that most meetings have no planned structure. OSCAR is a simple process for structuring a meeting agenda. The researcher will discuss how leaders can facilitate meetings by using the OSCAR coaching model and meeting agenda in more detail in Chapter 4.

The researcher decided to focus on the OSCAR coaching model. This coaching model will be implemented in South Africa as a coaching model to ensure effective distribution of leadership and more effective schools.

A discussion on previous findings on coaching as part of the distributed leadership will follow.

3.7 PREVIOUS STUDY FINDINGS ON COACHING AS PART OF DISTRIBUTIVE LEADERSHIP STRATEGY

The researcher included six examples of previous studies that show that the coaches can distribute leadership in their daily tasks as coaches. Carter (2001) conducted a four-phase study in Great Britain to determine what executive coaching is, why schools use it, what issues are involved, and where executive coaching fits in terms of management learning theory.

Data were gathered by means of a literature review, in-depth interviews with management development specialists and others in schools using executive coaching, in-depth interviews with executive coaches along with document analysis and discussions, and a forum of Institute for Employment Studies Study Club members in England. The study involved 22 people in 14 different schools. The study found that executive coaching is a process of work-related development for senior and professional managers that includes business, functional and personal skills. The process includes entry and contracting, identifying issues, reaching a shared diagnosis, planning to address development needs, action taking and reflection and closure. Schools use executive coaching for accelerated development, implementation of change, provision of a critical friend, and underpinning wider development programs. In addition, it is used to reward and retain key staff. Implementation of executive coaching involves a myriad of issues, including credentials of coaches, matching managers and coaches, "coaching envy", cost, trust and control, and evaluation. The study also found that executive coaching fits within the field of development, linking it to mentoring and career counselling, learning on the job, a "meta-process" maximising learning, or a mediatory process between career management "thinking" and "action".

Rhodes and Beneicke (2002) conducted a study on school performance and school improvement. Different policy-driven initiatives, including the prescription of standards, enhanced self-management opportunities, school restructuring, professional development of staff and statutory interventions, such as literacy development, have underlain the pressure and support offered by governments

to raise standards in schools. Coaching, mentoring and peer-network mechanisms, which have had prevalence outside education, are being seen as important within education as a means of assisting the raising of standards and attainment. This study concerns itself with the use of coaching, mentoring and peer-network mechanisms in schools as a means to enhance professional development, embed changed practice and encourage the transmission of teacher learning to pupil within classrooms.

The potential benefits of the deployment of such mechanisms within schools were reviewed, and the study highlights management issues within schools likely to emerge, should individual schools adopt or give additional prominence to the use of such mechanisms as a means to enhance professional development.

Buckingham and Clifton (2001) explain that many experts agree that a plan to capitalise on executives' strengths' rather than to focus on shortfalls. Hall (2005) conducted a scientific study of what makes people function at their best and experience fulfillment and well-being. The study focuses on positive psychology and emphasises what is working, what one does well and how to do it better, instead of discussions of weakness and limitations. Hall found in her study that employees who receive coaching are often successful senior leaders who are facing career challenges because of school changes. The stigma of coaching as a consequence of poor performance is changing and is evidenced by the fact that almost as many respondents view coaching as an engagement tool as they do a way to address workplace problems.

Penuel, Frank and Krause (2006) analysed in their study how well access to expertise predicted the influence of reforms on teachers' practice. They relied on longitudinal data obtained from two surveys of teachers' social networks and self-reported effects of their school's initiative on their practice. Among resources analysed, they found that access to materials and time for collaboration were not predictive of teacher change, but reported access to mentors and coaches was. They also found that when teachers received help from colleagues who had already been implementing their school's initiative, they were significantly more likely to change their practice. These two findings suggest that interactions with

colleagues function as continually changing resources that help individuals interpret and apply the demands of initiatives for their own practice, helping reduce variability in reform implementation.

Sharratt and Fullan (2009) discovered in their study the crucial role that literacy coaches played in schools. They worked with 17 low-performing schools and the schools improved significantly. The coaches typically spent their day planning lessons with classroom teachers, modeling lessons, observing instruction, facilitating meetings, reviewing learner data, and leading the collaborative marking of learner work. Literacy coaches worked closely with principals to implement 14 key parameters for success. These parameters are strategies that improve learners' literacy achievements and include:

- Shared beliefs and vision
- Embedded literacy coaches
- Timetabled literacy blocks
- Principal leadership
- Early and ongoing intervention
- Case management approach
- Literacy professional development
- In-school grade and subject meetings
- Book rooms with leveled books and resources
- Allocation of resources to literacy learning
- Action study focused on literacy
- Parental involvement
- Cross-curricular literacy connections

- Shared responsibility and Accountability

Mourshed, Chinezi, and Barber (2010) published a report that looked at how school systems of poor schools improved to fair schools in developing countries with a clear focus on interventions on accountability and professional learning. However, countries that had gone from great to excellent focused 78 percent of their interventions on professional learning and only 22 percent on accountability.

Morshed, Chinezi and Barber conclude that once the capacity of teachers reaches a certain level, peer culture becomes the source of innovation and energy and peers become change agents. When teachers, principals and coaches work in coordinated teams deep change will occur. The work of coaches is crucial because they change the culture of the school as it relates to instructional practice.

3.8 THE INFLUENCE OF INTERNAL COACHING TO ENHANCE THE DISTRIBUTION OF LEADERSHIP

Hyman and Cunningham (1995) explain that in many schools the responsibility for the development of employees is devolved to line managers. Tamkin, Hirsh and Tyers (2003) add that there has been a shift from the role of the manager as controller to that of a coach or mentor, of which the development of the employees is a major part. Internal coaching is a one-on-one developmental intervention supported by the school and provided by a colleague of those coached who is trusted to shape and deliver a programme yielding individual professional growth (Frisch, 2001).

Internal coaching has certain advantages for schools. Firstly, according to the International Coaching Federation, also known as the ICF (1999) internal coaches have much more in-depth knowledge about the school and culture. They are able to work more quickly and they are easily contactable and available. Secondly, Senge (1990) adds that internal coaching is also compatible with the learning school. Lastly, Germann (2002) argues that schools can achieve more leverage by developing coaches within a school than by means of any other activity because internal coaches are essential for continually developing skills

that will benefit the school in real time and can be applied every day as new opportunities and challenges arise. According to Frisch (2001), internal coaches must have certain competencies. Table 3.12 will give clarify how internal coaches can distribute leadership within schools.

Table 3.12: Internal coaching and distributed leadership (International Coaching Federation, 1999).

Competencies of internal coaches	Internal coaches can distribute leadership by means of
Build trusting relationships	Hatcher (2005) explains that democracy adds to distributed leadership and recognised the capabilities of staff members and that the leader trust followers to share power (par 2.5.2).
Innovative and creative approach to their work	The National Quality School Framework in Australia (Department of Education, Science and Training, 2003) initiates innovation by means of sharing a focus on action; culture building and school-wide learning (par 2.5.6).
Have expertise in management issues	The National Quality School Framework in Australia (Department of Education, Science and Training, 2003) empowers staff to share leadership for school development and manages the processes that lead to sustained improvement (par 2.5.6).
Good listening skills	Raelin (2006) states that a coach is part of the collaborative leadership strategy. Bell (1998) adds that instead of concentrating on self-expression, one engages in deep listening. A good coach must also be a good listener (par 2.5.5).
Open to continuous learning opportunities	Smylie, Conley and Marks (2002) explain that teacher inquiries in collaborative context create new opportunities for teachers to learn. This could lead to improvement of their schools (par 2.5.3).

Table 3.12 clarified that internal leaders can distribute leadership by means of teacher, collaborative, shared and democratic leadership. Internal coaches can be utilised within schools to assure schools that are more effective.

3.9 CONCLUSION

Chapter 3 gave a literature overview of coaching as distributive leadership strategy ensuring schools that are more effective. The chapter addresses the study question: How can distributed leadership be used as a successful and effective leadership strategy? A discussion was given on the collaborative nature of coaching as a seven-stage pattern that links to the distributed leadership strategy. An explanation was given on the role of coaches within educational settings. Five coaching models that can assure that schools are more effectively managed were discussed. Each of the coaching models was linked to distributed leadership. Coaching models included the GROW coaching model, STRIDE

coaching model, OSCAR coaching model, strategic executive coaching model and team coaching model. A further discussion followed on the role of coaches to distribute leadership by means of coaching to assure effective schools.

The researcher also gives an indication that the OSCAR coaching will be implemented as model to assure schools in South Africa that are more effective. A discussion was also given on the influence of internal coaching to enhance the distribution of leadership within schools. The chapter also guided the researcher towards the achievement of the major study problem: What is the role of distributed leadership as strategy to ensure effective schools in South Africa? Chapter 4 will explain the ways in which one design, implement and maintain coaching as a distributed leadership strategy to ensure effective school leadership in South Africa.

CHAPTER FOUR STUDY METHODOLOGIES

4.1 INTRODUCTION

The previous chapter reviewed literature on how coaching can be used as an effective and successful distributed leadership strategy. The current chapter explores ways in which one designs, implements and maintains coaching as a distributed leadership strategy to ensure effective school leadership in South Africa. This will include the research design, target population and sampling, instrumentation and data collection techniques, data analysis and interpretation.

4.2 RESEARCH DESIGN

4.2.1 Introduction

This study is based on a qualitative research design, and is narrative in nature rather than statistical and data was collected in words rather than figures. Kaplan and Maxwell (1994:132) explain that the *goal of understanding a phenomenon from the participants' point of view and its particular social and institutional context is largely lost when textual data are quantified*. In the next section, the researcher will discuss the rationale for choosing the qualitative research design.

4.2.2 Rationale for choosing the qualitative research design

Creswell (1994) defines a qualitative research design as an inquiry process of understanding a human problem, based on a holistic picture, formed with words and detailed views of informants, conducted in a natural setting. Creswell (1994) adds that a qualitative research design is conducted by the researcher who studies events in their naturally setting, in the case of this research the educators in their natural settings as leaders within their schools. The researcher aimed to investigate in this research the role of distributive leadership to ensure effective schools in South Africa. The researcher will explain the rationale for choosing the qualitative design for this particular study in more detail.

The overall purpose of adopting the qualitative research design for this study is to gather data through investigating and understanding of the challenges to the implement distributed leadership as strategy to ensure effective schools in South Africa. Strauss and Corbin (1990) contend that qualitative research is used to understand variables that are difficult to quantify, such as attitudes or political opinions about a specific population or group of people. The literature in chapters 2 and 3 indicated that a theory base would not be efficient to guide the study as not much has been written about the role of distributive leadership as strategy to ensure effective schools in South Africa. As a participant observer, the researcher strived to listen to school management members and other leaders in order to build a picture of the distribution of leadership to ensure effective schools in South Africa. The researcher chose a research design based on ethnographic principles. Firstly, McMillan and Schumacher (1997:427) explain that *“ethnography is interactive research requiring extensive time on site to systematically observe, interview and record processes as they occur naturally at the selected location”*. Secondly, Charles (1998) describes ethnography as exploring behaviour holistically in a social setting of customs, values and styles of communication. Thirdly, Scott and Usher (2000:87) state, *“ethnographers study segments of social life that are naturally occurring and that seem to have clear boundaries like activities in a school over a determined time”*

In this study, ethnographic research has been practised, as the researcher could observe, interview and record the processes as they occur in a natural setting. The researcher, in this study, became a participant observer whereby the participants' thoughts and beliefs were noted. By actively listening to the participants the researcher could see the world as the participants do and put aside their perceptions in favour of those of the participants. In this study, the researcher observed the actions and behaviour as they occurred in the environment of the participants.

Authors such as Cohen, Manion and Morrison (2000) add that phenomenology studies direct experience taken at face value where one's behaviour is determined by the phenomena of experience rather by external, objective and

physically described reality. Thus, detailed descriptive field notes could be made to provide an in depth understanding of the role of distributive leadership to ensure effective schools in South Africa. It is of particular relevance to the study that this strategy is used so that the effectiveness of the distribution of leadership could be studied as leaders give their opinions, suggestions and recommendations. Best and Kahn (2003) explain that symbolic interactionism is the belief that people act according to how they understand the meaning of words, things and actions in the environment. Cohen *et al.* (2000:25) add, *“human beings act towards things on the basis of the meaning they have for them, and the participants could then account for their actions, interact with others and negotiate”*. The researcher applied additional research approaches to gain a deeper understanding of how leadership distribute leadership to ensure effective school.

4.2.3 Additional research designs

The participants in this study were from different cultural backgrounds, schools and thus understood the world around them from different perspectives. The researcher used different strategies as he was interacting, observing and understanding social activities as practised by the participants in their schools.

Firstly, the research adopted the explorative research design as additional research approach. Mouton (2001:102) commented that exploratory research is implemented *“when the research area is relatively unknown and may have as an aim the gaining of new insights in, and comprehension of a phenomenon”*. Although leadership development is not an unknown phenomenon to leaders in general, the leader in a functional school environment in a South African context is acquainted with the dynamics and processes of these phenomena. The life-world of leaders in functional schools can therefore is seen as “unknown” by other social population groupings and an ideal research domain to be explored.

Important research design considerations of this type of research are the need to follow an open and flexible research strategy. Mouton and Marais (1993) hold the view that there is the need to use methods such as literature reviews, and

the need for the researcher to be willing to examine new ideas and to open to new stimuli. In this research the purpose of exploratory research was to gain insight into the perspectives, experiences of a specific group of people in a specific context and to determine “what” their experiences of leadership are about. Methods that will lead to insight into, and comprehension of, the phenomenon of distributed leadership will be employed. The development of leaders will be observed by means of interviews, field notes and document analysis. An additional research approach will be to use a descriptive research approach.

Secondly, the descriptive research approach is about the “*how*” and “*who*” questions, which are “*how did it happen*” and “*who is involved*” and “*exploring why something happens is less of concern in descriptive research than describing “how” things are*” (Neuman, 1997:20). Neuman (1997) explains that descriptive and exploratory research has many similarities and they often blur together in practice. Furthermore, Mouton and Marais (1993) add that the objective is to describe what is accurately and exactly as possible. Moreover, states that descriptive research focus

Bogdan and Biklen (1992) comment that what is described can eventually contribute to the expansion of knowledge in this study. This research not only endeavoured to understand human behaviour, but also to describe how things were practices of key persons. Descriptive research was utilised to describe the interpretations of leaders regarding their life world and development and experiences as leaders in functional schools. Descriptive research allows the researcher to produce an in-depth description of a phenomenon such as the distribution of leadership to ensure effective schools in South Africa.

Lastly, Mouton and Marais (1993) employ a contextually bound strategy rather than the universal strategy usually followed in qualitative research. This implies that the phenomenon researched is in accord with its immediate context. Silverman (1993:8) comment that applying contextual sensitivity implies “*recognition that apparently uniform institutions take variety of meanings in different context* and the understanding that participants in social life actively

produce a context for what they do". Strauss and Corbin (1990:101) add that a context represents a set "*specific properties that pertain to the phenomenon that is the location of events or incidents pertaining to a phenomenon along dimensional range. It is a particular set of conditions within the action strategies are taken to manage, handle, carry out and respond to a specific phenomenon*".

This involves the indirect exploration analysis and description of phenomena in their natural environment (Streubert and Carpenter, 1995). Contextual research is therefore done in leaders' interest as representative of the larger population of similar populations. The cases selected for this research were leaders from functional schools.

Being concerned with the content of real experiences, it follows that this study is of a contextual nature. Maykut and Morehouse (1994) confirm that qualitative research values are sensitive to context, as it aims at understanding a phenomenon in all its complexity and in a specific situation and environment.

Communities within the context of functional schools are the crucial context where leaders are being identified, appointed and developed to act as leaders in such a setting. The functional schools (in the Amajuba District in the Province of KwaZulu-Natal) as the context of the present research are important, because they display distinctive properties of how the leaders are identified, developed and appointed, or what the leaders' personal understanding of distribution of leadership to ensure effective schools in South Africa might be.

A functional school is complex place with major features and related to the complexity of school leadership and future development to ensure effectiveness:

- Basic functionality of the school;
- Leadership, management and communication;
- Governance and relationships;
- Quality of teaching and educator development;
- Curriculum provision and resources;

- Learner achievement;
- School safety security and discipline;
- School infrastructure; and
- Parents and the community.

The research has enabled the researcher to indulge in a prolonged engagement in the field and gain insight into the nature of the many aspects that need to be taken in consideration. This has taken place in functional schools, often unexpectedly and simultaneously and against a specific background or history.

In this section, a detailed explanation was given on the additional research design to support the qualitative research design that was chosen for this study. The aims of the research are discussed in the next section.

4.3 THE RESEARCH PROBLEM

Chapter 1 (par.1.3) indicated clearly that the South African leadership study base is very limited. Evidence also illustrated (par 1.3) that little formal leadership or management training exists and that principals are appointed based on their teaching record, rather than their leadership or managerial potential. By means of this study, the researcher wants to develop a model that will serve as the frame of reference for the empowerment of leadership teams at schools, especially in the KwaZulu-Natal Province in South Africa. The researcher also has to provide the Department of Education of KwaZulu-Natal with a report on the findings and recommendations regarding this study. The study focused on the distribution of leadership at five selected schools in KwaZulu-Natal (par 1.3). Due to the structure of the primary school curriculum, it is vital for the senior leadership team to be aware of different leadership techniques to manage primary schools effectively. The major research problem identified for this study is:

“What is the role of distributed leadership as strategy to ensure effective schools in South Africa?”

The researcher had to clarify a set of research questions to create an outcome for the above identified research problem. The researcher identified and clarified the research problem in section 4.4. The researcher also made it clear that a set of research sub-questions had to be defined to create a possible outcome for this study.

This study was guided by the following sub-questions in order to determine the views of senior leadership teams, middle leaders and classroom educators on the distributed leadership approach as leadership strategy (par 1.3 and 1.4):

- What are effective school leadership, leadership strategies and distributed leadership?
- How can distributed leadership support change and improve effective schools?
- How can coaching been used as a successful and effective distributed leadership strategy?
- How does one design, implement and maintain coaching as distributed leadership strategy to ensure effective schools in South Africa?
- How can a distributed leadership model be conceptualised as a leadership strategy in South African schools to ensure effective schools in South Africa?

The researcher will describe the aims of the research in the following section.

4.4 AIMS OF THE RESEARCH

The researcher aims to investigate whether schools follow a leadership model where decision-making is distributed among the rest of the senior leadership team and leaders at the school, instead of being led by one leader only. The researcher's aims emanate from the research problem, namely what is the role of distributive leadership as strategy to ensure effective schools in South Africa. The researcher also attempts to define effective school leadership, leadership

strategies and distributive leadership through this study and to explore how distributive leadership supports change and improves schools effectively.

The focus of the study is to obtain data that could facilitate an understanding of the participants' experiences on the role of distributive leadership as strategy to ensure that schools in South Africa function more effectively. It is the understanding that this data will form the basis for the conceptualising for school management and other leaders that will facilitate the successful management of the implementation of this approach. In order to achieve the aims of this study, a qualitative research design was adopted. The research problem is explored below.

4.5 POPULATION AND SAMPLING

McMillan and Schumacher (1997:164) define the population as “*a group of elements or cases, whether individuals, objects or events, that conform to specific criteria and on which the researcher intends to generalise the results of the research*”. Fraenkel and Wallen (1993) add that the population is the group of interest to the researcher, the group on which the results of the study will be generalised. In this study, the population referred to all the 27 primary schools in the Pumela Ward, in the District of Amajuba and in the province of KwaZulu-Natal in South Africa (par. 1.5.2). The knowledge gained was representative of the total population under study. Fraenkel and Wallen (1993:556) explain that the “*group on which information is obtained is preferably selected in such a way that the sample represents the larger group (population) from which it was selected*”.

Fraenkel and Wallen (1993) mention that sampling processes in qualitative research are dynamic and ad hoc, rather than static parameters of populations for a research design. For this study, the sample was selected purposefully (par 1.5.2). Maxwell (1996) explains that purposive sampling is a strategy in which particular settings, persons or events are selected deliberately in order to provide insight into important information that cannot be obtained from other situations, persons, or events as well.

Talbot and Edwards (1994) state purposive sampling is research based on knowledge and expertise of the participants selected for the study. In this study, the sample referred to 28 leaders from the five public primary schools in the Amajuba District. There were a total number of 28 participants in this study and the researcher ensured that the rights of all participants were protected by applying the rules for ethical measures as identified by the University of South Africa.

4.6 ETHICAL MEASURES

4.6.1 Competency of the researcher

Researchers must be competent, accurate and above all honest in whatever they do. Brink (1996) further states that the researcher has to apply other principles that deal with sensitive issues such as honesty and integrity when conducting research. Strydom (1998:31) explains that *“an ethical obligation rests with the researcher to ensure that they are competent and skilled to undertake the investigation they have in mind, the researcher’s methodology and interpersonal skills”*(Appendix B). The study was supervised by one supervisor who is an expert in this field of educational management and who is actively involved in qualitative research. The researcher also had an acceptable relationship with the participants.

4.6.2 Relationship with participants

The researcher tried to make the research as transparent as possible. The rationale was to maintain a healthy relationship between the researcher and the participants. Following Schurink (1998), the aim of the proposed investigation, as well as the envisaged use of the results, was clearly set out. Participants were informed about the study and its purposes, practical aspects of the research, time investment and usage of digital recorder, as well as possible inconveniences. Participants were given the option whether or not to participate in the study and they were allowed to withdraw at any time when they felt uncomfortable, without any penalty. More information was given to participants about where to contact the researcher, if necessary, to validate interpretations

from interviews, to make any changes, or when they had questions or queries about the research process. The researcher had to protect the rights of the participants throughout the research.

4.6.3 Protection of human rights

Demonstrating respect for participants by protecting their rights, the researcher has a responsibility to demonstrate respect for the scientific community by protecting the integrity of scientific knowledge. According to Shaughnessey and Zechmeister (1997), researchers take responsible measures to honour all commitments they have made to research participants. To ensure this, the researcher followed the Bill of Rights of South Africa (Constitution of the Republic of South Africa, 1996). Participants were treated respectfully and courteously at all times.

4.6.4 Informed consent

According to Neuman (1997), it is not enough to obtain permission from the participants. They also need to know in what they are being asked to participate in order to make an informed decision. Strydom (1998) explains that informed consent implies that adequate information on the goals of the research study and the procedures followed, with all the possible advantages, were rendered to the participants. Informing participants should be done in such a way as to encourage free choice of participation. Participants may withdraw from the research at any time. The time required for participation, as well as the non-interfering and non-judgemental research role was explained to the participants. Shaw (1999) states that, to gain informed consent, the researcher must make those being studied aware of the following:

- That they are participating in the research;
- The purpose of the research;
- The procedures of the research;
- The risks and benefits of the research;

- The voluntary nature of research participation;
- The right of the participant's to stop the research at any time; and
- The procedures used to protect confidentiality.

Formal consent was obtained from the relevant institutions before engaging in any form of research technique with them. Firstly, permission was gained from the Deputy General of Education in KwaZulu-Natal to conduct the study (Appendix A). Before conducting the research at the respective schools, the consent of principals and the teachers to participate in the study was also obtained (Appendix C). The permission letter obtained from the Deputy General of Education in KwaZulu-Natal was shown at all schools participating in the study. Interviews were conducted during times most convenient for each of the schools. Data were collected in the participants' most convenient language, while their norms and values were also respected. Although the main language for the research was English, the researcher remained flexible and used Afrikaans where possible in order to clarify some issues. This helped not only to simplify the issues, but also to create a good rapport with the participants. Freedom of choice, like language preference and human rights, was respected, which ensured that all participants were treated fairly throughout the study.

4.6.5 Fair treatment

The participants were informed of their rights to withdraw without penalty or remain in the study, should they so wish. The researcher should not collect more data than was necessary to achieve the objective of the study. Brink (1996) states that the selection of the population and participants to the study should be fair and participants should be respected at all times.

Participants should be selected for reasons directly related to the problem being studied, and not because they are easily available or can easily be manipulated, or because the researcher wants them to receive the specific benefits of a study. Brink (1996) states that participants should be treated fairly and the researcher should respect any agreements made with the participants. The researcher

ensured that the privacy of the participants was protected during the duration of the study.

4.6.6 Privacy

Privacy refers to the rights of individuals to decide how information about them is to be communicated to others. Whenever possible, the manner in which data about participants will be kept confidential should be explained to participants so they may judge for themselves the safeguards taken to ensure their confidentiality is reasonable (Shaughnessey and Zechmeister, 1997). Brink (1996:38) states that privacy is *“the freedom an individual has to determine the extent and general circumstances under which private information should be shared with others. Furthermore, private information includes one’s attitude, beliefs, behaviour, opinions and records. An invasion of privacy occurs when private information is shared without an individual’s knowledge against his or her will.”*

Strydom (1998) adds that privacy is that which normally is not intended for others to observe or analyse. De Vos (2000) concurs by stating that privacy implies the element of personal privacy. The researcher took the necessary precautionary measures whereby all participants reserved the right to decide for themselves to what extent their attitudes, beliefs and behaviour were revealed. The handling of information in a confidential manner will be discussed in the next section.

4.6.7 Confidentiality and anonymity

According to Strydom (1998), confidentiality is the handling of information in a confidential manner. The names of schools and all participants who participated in this research were withheld. Yegidis and Weinbach (1996:34) commented that it is *“imperative that researchers be reminded of the importance both of safeguarding the privacy and identity of participants and of acting with the necessary sensitivity where the privacy of participants is relevant.”* To ensure confidentiality and anonymity, participants were informed about the purpose of the research. They were also assured that their names would not be used. Brink (1996) refers to anonymity as an act of keeping individuals nameless in relation

to their participation in the research. The means of ensuring anonymity were used by code names when data was discussed. The researcher ensured that the correct procedures were followed at all times in order to adhere to ethical procedures.

4.6.8 Procedures that were followed

Participants were given information about all the research procedures, the depth of the interviews and the use of a digital recorder and the field notes. They were also informed that the interviews would last about 45 minutes. Participants were informed that they were expected to give as much information as possible during their discussions relating to their experience of the role of distributive leadership to ensure effective schools in South Africa. They were asked to portray their role as leaders in as much detail as possible and they should answer the researcher's questions as honestly as possible during the interviews. Permission to conduct the research was sought from the KwaZulu-Natal Department of Education, the school principals at the identified schools, as well as from participants. In order to establish the truth-value with regard to this research study, the researcher had to interview leaders who experienced the distribution of leadership to ensure effective schools in South Africa.

4.7 TRUSTWORTHINESS, RELIABILITY AND VALIDITY OF THE RESEARCH

Holloway and Wheeler (1996) noted that all research is rightly open to criticism and there must be criteria by which qualitative research can be evaluated. Measures to ensure trustworthiness were applied in this research to ensure the truth-value. Strategies as identified by Lincoln and Guba (1985) such as credibility, transferability, dependability and conformability were applied in this study.

Krefting (1991) comments that truth-value establishes how familiar the researcher is with the truth findings, based on the research design, informants and context. The value of this study was determined by using the qualitative approach of credibility. Schurink and Poggenpoel (1998) acknowledge that truth-

value asks whether the researcher has established confidence in the truth of the findings for the participants and the content in which the research is undertaken. Krafting (1991) explains that a qualitative study is credible when it presents such accurate descriptions or interpretations of human experiences that people who share that experience or perception would immediately recognise the descriptions. Truth-value is usually obtained from the discovery of human experiences as they are lived and perceived by participants. Truth-value is the most important criterion for the assessment of qualitative research.

Morse (1994) explains that credibility refers to the truth-value or credibility of the findings. The objectives of these are to demonstrate that the research was conducted in such a way that the participants were accurately identified and described. The participants in this research were specifically selected for the purposive sample because they had experience of leadership at the different levels at their schools. The research was aimed at five functional schools within the Pumela Ward in the Amajuba District of KwaZulu-Natal.

Focus-group interviews were conducted to achieve data saturation. The researcher stayed in field until the data had been saturated. Morse (1994) explains that saturation indicates that the researcher has done an exhaustive exploration of whatever phenomenon is being studied. This was achieved when the researcher noted that various participants were repeating the same themes.

Prolonged engagement was implemented to build trust. In this study, the researcher collected data about the role of distributed leadership to ensure effective schools in South Africa from participants to explore a problem or describe a setting; a valid process or pattern of interaction (De Vos, 2000). The researcher gave an in-depth description showing the complexities of variables and interactions of leaders' experiences of distribution of leadership to ensure effective schools in South Africa. This was done so that leaders who experienced the distribution of leadership recognised the description immediately.

Triangulation of the data collecting methods was achieved by focus-group interviews with leaders who experienced the distribution of leadership at primary schools, observations, and analyses of documents. According to Krefting (1991), this strategy is used to enhance the quality and credibility of research. In this study, the peer group evaluation was done by the supervisor who was appointed for this study to support the researcher throughout the study. *Applicability* refers to the degree to which the findings can be applied or transferred to other contexts, settings or other groups; thus, it is the ability to generalise from the findings to larger populations. Babbie and Mouton (2002) explain that transferability refer to the extent to which the findings can be applied in other contexts or to other participants. One needs to know whether the conclusions of the study are transferable to other contexts. Brink (1996) mentions that the researcher has to help provide the detailed data base and thick descriptions so that someone other than the researcher can determine whether the findings of the study are applicable in another setting.

Breakwell, Hammond and Fife-Schaw (2000) refer to the idea that one can speculate on the likely application of the data to other similar, but not identical conditions. Krefting (1991) explains that this is obtained by using a purposive sample and contextual descriptions. The aim of this research is to investigate the role of distributed leadership to ensure effective schools in South Africa. Krefting (1991) adds that another way of looking at transferability is the consideration of data rather than the role of the participants within the research. Furthermore, the researcher must determine whether the content of the focus group interviews, the analysis of the documentation and observed events are typical of the participants' role within the research.

Poggenpoel (1998) is of the opinion that the strength of the qualitative method is that it is conducted in natural settings with few controlling variables. Holloway and Wheeler (1996) describe transferability as the way in which the findings can be generalised or transferred from representatives of the population to the whole group.

The following activities were followed to improve transferability:

- Description of the demographics of the participants;
- Purposive sampling was used to select leaders who experienced the distribution of leadership to ensure effective schools; and
- Dense explanation of the results.

To make transferability possible, the researcher aims to provide a dense database. According to Babbie and Mouton (2002), transferability in a qualitative research study depends on similarities between sending and receiving context. Literature control and verbatim quotes from the focus-group interviews were obtained as well from the observations and analysis of documentations. This was done to compare the focus-group findings with the observation and analysis of documentation regarding the distribution of leadership to ensure effective schools in South Africa.

The control measure of consistency is dependability. Holloway and Wheeler (1996) state that one of the ways in which a research study may be shown to be dependable as opposed to consistent is for its process to be audited. To ensure dependability, the following activities should be carried out:

- Stepwise repetition of the research method;
- Code-recode procedure and data analysis; and
- Dense descriptions of the research methodology.

Poggenpoel (1998) explains that neutrality refers to the degree to which the findings are a function solely of the participants' informants and conditions of the research and not of other biases, motivation and perspectives. Krefting (1991) adds that objectivity is the criterion of neutrality that is achieved through rigour of methodology that is reliable and valid.

Lincoln and Guba (1985) explain that the criterion of neutrality is considered to be achieved when truth value and applicability are established. Holloway and Wheeler (1996) point out that conformability means that the data are linked to their sources for the reader to establish conclusions and interpretations that arise from them.

4.8 INSTRUMENTATION

A qualitative study design permits data collection through observation and analysis of the collected data by describing interactions and developing themes, making use of an established theoretical framework from the literature. Neuman (1997) explains that the qualitative study design also involves open-ended and free-response, unstructured and structured interviews, as well as the analysis of documents allowing the subject to speak for itself.

A qualitative study design is used in this study, as it provides participants with the freedom to present data from their perspective. In addition, data collection is open and flexible, taking into account the relationship between the researcher and the participants. Interviews were used as the main data collection technique in this study. Data will be collected in three stages during the study. During phase one of the study, the researcher prepared the interview schedule. The initial preparation included permission from the KwaZulu-Natal Department of Education to carry out the study project and involved writing an official letter to request such permission. Phase one lasted one month.

The conduct of the interviews formed the second phase of the data collection process. The researcher conducted 28 semi-structured interviews at five functional schools to get information on the state of effectiveness of schools in South Africa. Open-ended questioning allowed the respondents to give detailed answers and to share their opinions on the subject of distributed leadership as a leadership strategy. Therefore, phase two of the data collection process in South Africa lasted one week.

During phase three of the data collection process, the researcher collected documents from functional schools. Documents are a very important source of information and, considering the study question and the purpose of the study, the researcher made use of documents such as the school policy for all schools to establish how distributive leadership is managed.

Documentary analysis was used because it produces data with high validity, as data are readily available and, unlike data from interviews, data collected by means of documentary analysis are not prone to manipulation by study subjects. The researcher discusses the fieldwork and data collection procedures in the next section.

4.9 FIELDWORK AND THE DATA COLLECTION PROCEDURES

A primary characteristic of qualitative research is that the researcher is the primary instrument for data collection and analysis. Merriam (2001:7) comments that *data are mediated through the human instrument, the researcher, rather than through some inanimate inventory, questionnaire or computer. The researcher is responsive to the context, can adapt the techniques to the circumstances, considering the total context, can expand what is already known about the situation through sensitivity to non-verbal aspects the researcher can process data immediately and can clarify and summarise as the study evolves.*

In this study, the researcher made use of four instrumentation techniques: literature control, interviews, observations and documentation analysis. These three techniques will be elaborated upon in the paragraphs below.

4.9.1 Literature control

The literature control in the present research was done when the data analysis was completed. The research was exploratory and literature was used inductively so that it did not direct the research question asked by the researcher. The literature control was utilised to compare and contrast the themes and categories that emerged from the research, so that it served as an aid, once patterns or categories had been identified (Creswell, 1994).

The categories and the patterns identified were compared to literature on educational leadership, distributed leadership and coaching, and research done on the topic. Once this had been completed, concepts from the structured data were identified defined and described. The researcher used these concepts to determine the questions which were used during the interview process.

4.9.2 Interviews

Authors such as Cohen, Manion and Morrison (2000) define an interview as a two-person conversation initiated by the interviewer for the specific purpose of obtaining research-related information. The researcher interviewed leaders at different leadership levels to gain a deeper understanding of the distribution of leadership in South African schools and explore the problems leaders' encountered whilst leadership tasks were distributed to other leaders within schools.

McMillan and Schumacher (1997) explain that ethnographic interviews are conducted with individuals or small groups. In this study, ethnographic interviews were conducted with individuals or small groups (educator with a teacher assistant) to elaborate upon their perspectives on their world and how they made sense of important events. De Vos (1998) notes that ethnographic interviews are essentially open ended to provide the participants with every opportunity to describe and explain what is most salient to them. In this study, open-ended questions were used so that the subjects could air their opinions from their own frame of reference. They were asked the same questions in the same order.

Fraenkel and Walen (1993:385) mention that interviewing is vital for the researcher to *“check the accuracy of the information and to verify or refute the information and impressions gained through observation. In the interview the researcher could observe the participants and repeat or explain to the participants the meaning of the question if the participants did not understand it”*.

The researcher used the interview to obtain a present perception of activities, roles, feelings, concerns and thoughts of the participants regarding the role of distributed leadership to ensure effective schools in South Africa. During the

interview sessions, the researcher introduced himself and explained the purpose of the interview.

The researcher obtained permission from the Department of Education (Appendix A), the principals and the participants themselves (Appendix B). The participants were assured of confidentiality and anonymity. McEwan and McEwan (2003) comment that those participants who are reluctant or unwilling to participate in the study will not be victimised as their participation is purely voluntary. There will be no deception and no humiliation of the participants, but a sense of caring and fairness will rather prevail so that the participants will feel empowered (McMillian & Schumacher (1993). The participants were asked if they had any objection to the use of a digital recorder and their permission was sought to use the device, even though its main disadvantage is that it tends to change the participants' behaviour and could result in artificial behaviour. Thus, the naturalness of the setting would be adversely affected. The interview schedule served as a guide because the researcher used probing questions that were guided by the participants' responses. The researcher guided the participants who responded in a vague manner and probed what they said to get deeper, significant insights, further clarification of responses and an elaboration of detail. As there would be direct observation of the participants, both their verbal and non-verbal body language would be noted. At the end of the interview, the researcher thanked the participants for their cooperation. The researcher also determined an interview protocol to be followed during the research.

4.9.2.1 The interview protocol

The researcher used the following interview protocol during the research. The school principal was contacted so that interviews could be conducted with the educators. Interviews would be conducted during school time because this was agreed upon by the principal and the researcher.

A suitable location to conduct interviews was organised with the principals of the schools, the aim being to ensure privacy the interview session and participants were therefore interviewed at their respective schools. Questions were

formulated to establish the role of distributed leadership to ensure effective schools in South Africa. The purpose of the interview was clearly stated to all participants before the interviews commenced. Participants were assured that confidentiality and anonymity would be maintained. Questions were repeated to give clarity and minimise misunderstanding. Permission was obtained from the respondents to use a digital recorder. Verbatim transcripts of the digital recordings would be used as a basis for data analysis. The researcher ensured that the interview protocol was followed at all times. He also established an interview schedule that was followed during the research process.

4.9.2.2 *The interview schedule*

The structured interviews comprised a list of specific questions (Appendix D). Nichols (2000:131-133) points out *“that a structured interview is mostly a question and answer session, therefore allowing the interviewer to receive direct answers from the participants. However, the interviewer may encourage the participant to clarify vague statements or to elaborate further on brief comments. Otherwise, the interviewer attempts to be objective and tries not to influence the interviewer’s statements”*.

The choice of the questions was based on the research aims and objectives. These questions were intended to reveal the challenges faced by the participants in the role of distributed leadership to ensure effective schools in South Africa. The questions were guidelines that allowed the participants to express their views, feelings and opinions freely. Probing questions would be used to prevent misunderstanding and to enhance the clarity of the study. There was no deviation from the list of the prepared questions, but extra remarks were injected into the interview process sometimes. In some cases, the participants were encouraged to clarify vague statements or to further or elaborate on brief comments. The interviews were recorded with the use of a digital recorder once permission from the participants had been obtained. The interviews were then transcribed.

As indicated in par.1.5.2, the principal, an SMT member, a head of department, a grade leader, a subject leader, a classroom teacher and a classroom assistant were included in the interviews because the study focused particularly on the role of distributed leadership to ensure effective schools in South Africa. However, during the interviews the researcher probed the principal and SMT members to elicit more data. The researcher attempted to remain objective and tried not to influence the participants' responses.

Henning, Van Rensburg and Smit (2004) explain that in an interview the researcher clarifies the research topic and aim as well as the role of the specific interview. This creates room for a good rapport between the researcher and the participants.

The freedom for the participants was within the scope of the study because of questions in the interview schedule that revolved around the role of distribution of leadership to ensure effective schools in South Africa. Due to this guided flexibility, there was little room for deviations from the intended data, which Breakwell, Glynis, Sean and Chris (1991) refer to as unanticipated discoveries. However, the participants gave very elaborate answers that provided rich, in-depth and comprehensive data for the study. Irrespective of these identified advantages of interviewing, some challenges of interviewing were also spotted.

As indicated above, some disadvantages associated with the interviewing technique as data collection were identified. Some collected data required much more time for analysis than expected. Open-ended questions used in the interview schedule caused some confusion in the responses, either because of the lack of the understanding of the questions by the participants or sometimes of struggling to understand the answers of the participants.

This misunderstanding of the collected data delayed the process of data interpretation. In this section, the interviewing was discussed and a brief description of its application in the research was described. During the entire interviewing and research process, observations as discrete research tools were also used and this will be discussed below.

4.9.3 Documentation analysis

Wiersma (1991) argues that other sources of data may reflect on a research problem. He maintains that these other sources often consist of records maintained on a routine basis by the organizations in which the study is conducted. In the current study, minutes of meetings, staff organograms, the distribution of staff, and school-visit development instruments were scrutinized, with the aim of establishing whether distribution of leadership would ensure effective schools in South Africa.

Best and Kahn (2003) point out that when using documentary sources, one must bear in mind that data appearing in print are not necessarily trustworthy. It is for this reason that the researcher employed interviews and observations, to establish whether the information as recorded in the documents corresponded with what the researcher obtained through interviews and observations. After obtaining all data, the researcher analysed and interpreted the data to establish whether schools distributed leadership to ensure effective schools within South Africa.

4.10 ANALYSIS AND INTERPRETATION OF DATA

In terms of the research methodology, the analysis of data can commence once exhaustive fieldwork has been done and the point is reached where data is ready for the final stage of the research. After analysis of the research data, feedback can be given in order to arrive at conclusions, thus allowing for the verification of theories and suggestion for future research or outlining of problems encountered and shortcomings in the research.

4.10.1 Analysis of data

Data analysis follows after all data have been gathered and summarised within the context of the research design. Data examination, using a variety of analytical techniques, often forms one of the most exciting phases of the research (Burns and Grove, 1987) and includes, for this research, the transcriptions of all digital recordings (Appendix E) and document analysis. It also uses the field notes as

an important source of data, with the school-visit development instrument an incredibly useful tool to verify the analysis of documents.

Janesick (1998) suggests the use of the following checkpoints for data analysis:

- reporting and interpretation;
- looking for empirical assertions supported by the data;
- using narrative vignettes and exact quotations of participants to support assertions;
- scanning all other reports, documents, letters, journal entries, demographic data, and the like;
- using direct references, including interpretive commentary related to the data, for data simply do not speak for themselves; including a theoretical discussion; relating the data to the theory that guided the study; giving a hint to readers of what will be included in the model of what occurred in the study; and
- stating clearly any and all ethical issues that arose in the study.

In analysing the data related to the research, the researcher will make use of a method of “bracketing” the transcriptions of the research interviews, using as a departure point participants’ responses to leadership, as employed by the researcher, to identify the underlying causes of distribution of leadership. The analysis is intended to establish what is to be termed *distribution of leadership and effective schools*, and for this reason, the researcher used different phases or cycles to interpret the data during the research.

4.10.2 Interpretation of data

Burns and Grove (1987:567) explain that there *is a return to abstract thought processes, because the creative use of introspection, reasoning and intuition again dominate the process and suggesting furthermore that there exists a continuum between the description and the evaluation of data*. Kvale (1983) continues by outlining six possible phases in the interpretative cycle of the research. The researcher considered these six phases as of extreme importance in the interpretation of the data generated for this research. A first phase is that

the respondent or participant spontaneously describes what he/she does, feels and thinks about the theme. No effort towards interpretation is made from either the respondent or the researcher. In the case of this research, it obviously refers to the first interviews. A second phase is to be found in the discovery by the respondent of new relations and or meanings in what is said, done and experienced. In a third phase the interviewer may condense and interpret on a continuum that which the respondent is describing or saying, and may give direct or indirect feedback to the respondent. The respondent, in turn, may react by entering into dialogue with the researcher. A fourth phase or interpretation refers to the task of the researcher engaging in the interpretation of completed and transcribed interview material. Kvale (1983) demonstrates three levels of interpretation, namely self-understanding, common sense and theory. A fifth interpretation is the re-interview, also described as a "self-corrective" interview (Kvale, 1983), during which the respondent is given the opportunity to correct and elaborate upon the interviewer's interpretation of statements. It is especially in this context that the testing of the Oscar coaching model to ensure effective meetings in the research is expected to be extremely valuable. Finally, Kvale (1983) mentions a sixth possible phase of the interview, in that the continuum of description and interpretation is extended to involve action as well. This would imply that the participant begins to act from new insights gained during the interview.

Burns and Grove (1987) comment that interpretation signifies within the process itself a large variety of intellectual activities embracing the examining of evidence, forming of conclusions, considering implications, exploring the significance of findings, generalising these findings and suggesting further research.

4.11 CONCLUSION

In chapter 2, the theoretical framework of the theories and practices of distributed leadership as strategy in schools were explained. Chapter 3 guided the researcher towards coaching as distributive leadership strategy ensuring schools to be more effective. In chapter 4, the researcher achieved the objective: - *"to explore ways in which one design, implement and maintain coaching as a*

distributed leadership strategy to ensure effective school leadership in South Africa.

The researcher also answered the sub-question: *-How does one design, implement and maintain coaching as a distributive leadership strategy to ensure effective schools in South Africa?*

The rationale for choosing the qualitative research method was explained. The researcher also gave reasons why the explorative, descriptive and contextual research design was used in this study. Explanations were given on the ethical measures used in the study. The strategies and measures to ensure trustworthiness were also explained in detail. Clear descriptions were given on methods to collect and analyse data. In chapter 5, an explanation will be given of how a distributive leadership model can be conceptualised as leadership strategy to ensure effective schools in South Africa.

CHAPTER FIVE DATA PRESENTATION, ANALYSIS AND INTERPRETATION

5.1 INTRODUCTION

Chapter 4 dealt with the ways in which one designs, implements and maintains coaching as a distributed leadership strategy to ensure effective school leadership in South Africa. The researcher made use of four instrumentation techniques: literature control, interviews that were digital recorded, observations and documentation analysis. The digital recordings were transcribed and then categorised. The researcher achieved the objective, namely to explore ways in which one designs, implements and maintains coaching as a distributed leadership strategy to ensure effective school leadership in South Africa. He also addressed the sub-question in detail, namely how one designs, implements and maintains coaching as a distributed leadership strategy to ensure effective schools in South Africa.

In this chapter the focus is on the objective, namely to explain how a distributive leadership model can be conceptualised as leadership strategy to ensure effective schools in South Africa. The sub-question is also discussed, namely how a distributed leadership model can be conceptualised as a leadership strategy at South African schools to ensure effective schools in South Africa.

In their study, Spillane, Halverson and Diamond (2004) highlight the ways in which leadership is constructed from the widespread distribution throughout organisations and the extent to which leaders influence the contribution of others so that leadership is stretched over the social and situational contexts. The highlight of their study constitutes an important theoretical framework for the analysis and interpretation of data in this study. According to Banks (2007:8), *“scholars some years ago started debating positivism and the legitimacy of social research based on the scientific method”*.

Banks correctly indicates that practitioners of qualitative research emphasise and value the human, interpretive aspects of knowing about the social world and the significance of the understanding and interpretation of the phenomena under study. The interpretation of the data is discussed in the next section.

5.2 DATA INTERPRETATION

The following paragraphs present responses emanating from interviews at the schools under discussion. This could be indicative of the role of distributive leadership in South Africa in order to ensure effective schools. The interviews were guided by an interview guide comprising open-ended questions aimed at checking with leaders the effectiveness of distributed leadership in order to ensure effective schools in South Africa. The data were obtained from digital recordings with 28 leaders. As discussed in chapter 1, a total sample of participants to be interviewed will comprise twenty-eight (28) leaders from the five selected schools in South Africa. Leaders included principals, deputy principals and heads of departments, subject leaders, grade leaders, classroom teachers and assistants. However, in one of the samples, only four leaders participated in the study. This means that a total sample of 28 leaders was used in the study. All the data were transcribed and all participants are kept anonymous on request. The result will be reported, interpreted and integrated with the findings from the literature review that was captured in chapter 2 and 3. The researcher also wants to make it clear that the following clusters of leadership could be used in the report:

- Management – principals and deputy principals
- Middle leaders – heads of departments, grade leaders and subject leaders
- Class leaders – class teachers and teacher assistants

In this report, the results that were gained from the study of the documents obtained from the schools are interpreted and integrated with the findings from the interviews and the findings from the literature review in order to answer the main research question. The researcher will analyse and interpret the data in the next section.

5.3 DATA ANALYSIS

Authors such as Henning and Van Rensburg (2004) explain how open, axial and selective coding may be used in the analysing of qualitative data. In this particular study, open coding has initially been used to identify categories or themes and sub-themes emerging from the responses. The researcher identified the themes and sub-themes by drawing together significant events, feelings or concerns that relate to the research problem, as well as objective questions and sub-questions as expressed by the respondents. Axial coding was then used to explore the relationships among the themes. Such classification of data is important in order to clarify relationships and to obtain focused, meaningful interpretations.

The responses represent the lived experiences of the respondents. The perceptions, feelings and experiences of the participants at each sample are captured into broad categories. The data are examined and relevant issues relating to the research questions are clustered and categorised through open coding into eight categories. These include teacher leadership, teamwork, democracy and sharing of leadership, interaction between leaders, performance of the organisation, shared leadership, ensuring effective schools and whole-school development through meetings.

Table 5.1: Summary of themes and sub-themes derived from the data

Themes	Sub-themes
Theme 1: Distributed leadership is about teacher leadership	Initiate things; lead other teachers as class leaders, teamwork and motivation of teams
Theme 2: Distributed leadership is about teamwork	decision making, taxonomy of distributed leadership, time management, role of subject and grade leaders and sharing of knowledge and expertise
Theme 3: Distributed leadership is about democracy and sharing of leadership at all levels	Meetings, set an example, teamwork and involvement of younger teachers to make decisions
Theme 4: Distributed leadership is about interaction between all leaders	People skills, sharing teamwork, communication, meetings to discuss academic progress, one-on-one meetings, honesty, openness, monitoring of progress, collaborative work and sharing
Theme 5: Distributed leadership is about sharing of leadership and not the delegation of leadership	Responsibilities of principals, teacher leadership and coordination of leadership
Theme 6: Distributed leadership is about ensuring effective schools in South Africa	Extra opportunities for staff to develop, some schools still need leadership training to be effective, involvement of post level1 teachers to lead within the school, positive attitude, discipline of team members, clear job description, effective leadership of school management, teaching experience, clustering of schools which need support with effective schools, staff development, taxonomy of leadership, leadership skills development, ownership, responsibility and accountability, and sharing of work load and passion from all team players to succeed
Theme 7: Distributed leadership is about the development of coaches as a distributed leadership strategy	No formal training, some training
Theme 8: The OSCAR coaching model to facilitate meetings as distributed leadership strategy to ensure effective schools	Opportunities to plan once a week, decision making, development of staff, grade meetings, subject meetings, clubs, sport committees, minutes of meetings, development of curriculum, year meetings at beginning of year, monthly meetings, sharing of expertise, development of rural schools, phase meetings, mentors, pastoral systems, note taking, brain storming, collaborative team work and weekly meetings

In the above section, the analysis of the data was discussed. The researcher also identified eight themes and sub-themes. A discussion will now take place about the first theme, namely teacher leadership.

5.4 DISCUSSIONS OF THE THEMES

The categories with their category illustrations are used to demonstrate the application of theory in practice. The above themes with their related categories were elaborated and discussed in a way that simultaneously puts forward a framework of the role of distributed leadership as leadership strategy to ensure effective schools in South Africa.

5.4.1 Theme 1: Distributed leadership is about teacher leadership

This theme will give responses to: *What are effective school leadership, leadership strategies and distributed leadership?* This sub-question was formulated in chapter 1. Gronn (2000) describes distributed leadership as an emergent property of a group or network of individuals where group members pool their expertise (see chapter 1). In (par2.5.3) a clear discussion took place on the role of distributed leadership and the influence of teachers as leaders on the development of educational practices.

Sample A – Quotes from in-depth interviews

P1HOD: Educational leadership, in my viewpoint, is that you have to take the role, you have to initiate things and you have to be the convener, whatever you are doing.
P2HOD: The purpose of a leader at a school is to ensure that the vision and the mission of the school get finalised and all people fulfil it in full and to be a leader – as the word says – leadership.
P3HOD: Educational leadership is where one has to take control of one's class, be the leader in one's class, the work that one does in class must be the best for the kids. In my role as HOD I must set an example to other educators and I must be a good leader for them.
P4CT: Well, obviously leadership means leading; therefore one leads. Whatever one does in a - class, one leads, one takes. So, whatever subject you are doing you just take the lead as such. So interacting and sharing things with one another and helping one another, that is teamwork.
P5SJL: I think the first thing under educational leadership is that you as teacher must have the knowledge of your subject and therefore be a leader in your subject. Let's work together; then, how we are going to solve this will be more effective.
P6P: Educational leadership is that each educator should be a leader but at a different level in the school situation. So, my main job is to motivate my staff every morning before the day starts and to help them to try and make their lives easier by trying to have smaller class groups and have discipline in the school.

The collective view of the respondents was that it was important for teachers as leaders to take the leading role to develop their school. Harris and Lambert (2003) explain that leadership is about learning together and constructing meaning and knowledge collectively and collaboratively. Leadership involves

opportunities to surface and mediate perceptions, values, beliefs, information and assumptions through continuing conversations (see chapter 2). Management is of the view that managers need to motivate leaders to fulfil their roles as leaders to obtain the vision and mission statement of the school. According to Elmore (2000), leadership can be distributed through the components of leadership practices, mission, vision, goals, school culture and shared responsibility (see chapter 1).

SAMPLE B – Quotes from in-depth interviews

P7P: Make sure that education happens. I must moderate policies and individual personalities so that the child benefits in the class.
P8 SJL: Set example, lead and show what needs to be done. I am subject leader, there I also have to give all the information and see that the work is of a good standard. We come together and we discuss the work.
R9 GL: We work in a groups but it is still my job as leader to see that it is done properly. Make sure that the curriculum and planning is in place.
P10 DP: Well, leading in the first place your peers and those under you. Giving them an understanding of how to do certain things and why certain things have to be done.
P11 and 12 CT: and TA Well, I think after a few years of teaching you will get like a senior teacher and you have like a subject head and phase head and you must help the others and set the example and help them with problems and you are actually responsible for all the development in that phase or in that subject.
TA: Well, I think that the qualified teacher is, I look up to her and I learn a lot from her and then I want to be like her someday. I take her good points and I take her bad points.

There was clarity amongst the respondents that leaders needed to work together to ensure effectiveness within the school. Lashway (2003) states that in addition to an increased demand for meeting standards, principals are also asked to work collaboratively in an attempt to develop leadership in others. This request is based upon study revealing that school improvement takes place through collaborative learning communities (see chapter 1). At middle leadership level, it was clear that leaders needed to develop their subject areas and teaching groups through collaboration.

Gronn (2000) states leadership is one of a family of terms in both academic and common usage that is invoked to designate modes of human conduct and engagement (chapter 2).

SAMPLE C – Quotes from in-depth interviews

P13 DP: Educational leadership, I think, in the first place the educational leader must be very sure of the curriculum. He must know the curriculum and they must know what is expected from the Department's side to implement it in school and I think also to develop it. You must think about things and you must develop your curriculum further. You cannot stay where you are, so the curriculum is there to develop further because the children develop, especially through all the technology and things, you must keep up.

P14 HOD: Leadership. E educational subject-orientated subject knowledge. The child in his totality. His emotional leadership. You must be able to pinpoint the problem that the child might be experiencing. You need to give advice through to the teachers when they come to you and say "this child has a reading/spelling problem" or "this child did "this". This is linked to the subject, but it is also linked to the child's emotional leadership.

P15/16 CT and TA: CT: My role as a teacher I think we are here to educate the children and to develop them as far as possible in their individual personalities and ways. TA: In my role as a class assistant, I feel the same as the class teacher; we are there for the benefit of the child. The child's interests come first and they have to be enriched in all their areas as in personality, emotional behaviour and all that.

P17 SSL:As the subject head of social sciences I would say that educational leadership at the end of the day, if you are a head of a department doesn't mean that *you* need to do all the basic work involved in that department. You have got different teachers studying social sciences for each grade and certain tasks are supposed to be given down to other teachers to help you to make sure that there is a streamline. As a leader you don't always do all the necessary thinking and planning by yourself. You need to get other ideas from the other teachers so that you can incorporate or use all the different views from every teacher in the subject and use that as you go forward in your teaching ability. You have to make sure that as a leader you are not overruling everyone.

P18 P: Educational leadership. It is everything. It includes everything. All the aspects of a Principal's work, giving guidance to teachers within class and outside of class, taking into account the whole-school set-up. Also, all the aspects that need to be given attention and need to be married within the role of the parents, with the learners and with the teachers.

The respondents acknowledged the importance of teamwork to improve teaching and learning within the school. The respondents also accepted that effectiveness is based on the content and the implementation of the curriculum. Management is of the view that there need to be collaboration between teachers, parents and learners to ensure effective schools.

In chapter 2, Leithwood and Riehl (2005) state that students need to become learners who are more active and take greater responsibility for their own learning. The involvement of parents and the community is to promote the value of positive attitudes towards learning and to minimise the impact of challenging circumstances on the achievement of learners. Leaders need to develop schools

as professional learning communities and provide a range of learning experiences.

SAMPLE D – Quotes from in-depth interviews

P19 HOD: I think the first thing that I understand is that I think you have to lead by example. So, you cannot expect a group under you to work if you don't have a good work ethic. So, you have to be able to build the team first of all, make sure that they are a cohesive unit and then lead them by example.
P20 HOD: As HOD it is about running my school team and providing quality education to the learners and also bringing out the best in my staff that are under me.
P21 CA: For me it is being an example, having that impact on the children and the children learning from me. At the end of the day, that the children have an understanding, have learnt something from you, and take it and apply what they have learnt.
P22 CT: Well, I think it is a form of leadership obviously associated with education itself, which is teaching and learning. Then leadership comes in with you as an educator getting more skills to improve your teaching in the class so that you get better results in relation with the management of the school, your classroom and the total school environment.
P23 P: The term itself, 'educational leadership', is setting the role, being a role model in terms of being in an educational environment for educators as well as for pupils. That is what I see it is and what goes with that.
P24 CT: People who are a leader need to be in that role, I think, and people who have been in education and who know what education is about, that they keep up with the times and then they can help the other teachers that are under them. They should be democratic, I think.

From the evidence of the responses, it emerged that leaders need to lead by example to ensure effectiveness concerning teaching and learning. Most of the respondents also clarified that effective leaders were leaders who could have an impact on the learners they taught. In chapter 2, Muijs and Harris (2003) point out that evidence from school improvement literature consistently highlights that effective leaders exert a powerful influence over schools' capacity to improve learner achievement.

SAMPLE E – Quotes from in-depth interviews

P25 P: Well, that is a mammoth task. Difficult to answer in a simple sentence, but I basically go on the three legs of being a leader, a manager and an administrator. Your leadership is basically your inspiration your guidance, your empowering of those that work with you. That is in short.

P26 HOD: Well, my main idea as an HOD is leadership of the level1 teachers. That I am here to do as much as I can to lead the level1 teachers and to advise them. We do that by doing class visits and book reports, not continuously, but we do it throughout the year and from that I feel that we can see where there are needs, where they need to grow and on that we give advice. So, for myself as a person I am not so much into leadership as a management team member; I am more interested in the staff and how the staff develop and how I can help them and assist them to develop in their teaching to become better teachers and to give them ideas and so on and so forth. So, we do learn from each other, but yes, educational leadership is also of course the leadership of the school [the actual running of the school] in all aspects it comes into it. Of course we are all drawn into it because we all sit in meetings and discuss these things. So it is not just the teachers but as I said that is just my point of focus because that is what I like to do, help with the younger teachers and students and so on.

P27 CT: Educational leadership I think means that as an educator you need to give reaction to the learners. You need to assess learners with all the work and at the same time you have to take into account the conduct in which the learners are, try to help them, the work that need to be done by the kids needs to be the work that they are acquainted with. So, it should be related to the work that they do in school. As a leader you need to give direction for the children but don't do the work for the children. Let them be open minded, especially help them to use the media like the libraries and other things. Also, when you are in the class you also need to touch on the things that they do in their life situation. Not only to be theoretical in the activity. As a leader you need to give guidance to the children, help them to do the tasks that are given.

P28 CT: Leadership. In the classroom? Yes. In the classroom you are in charge, you give direction. As a teacher you give direction to the children – what do you want from them, what you expect from them and in return you get the product that you ask for.

The above evidence suggests that leaders in Sample E are generally teacher leaders. Leaders inspired other leaders through guidance and empowering of others who work below them. In chapter 2, Drath and Palus (1994) explain that collective leadership takes place when members in a group work together towards a common purpose and goal. Middle leaders see their role as teacher leaders to develop staff through teamwork. Class educators as leaders view leadership as a task to guide learners to be lifelong learners. Danielson (2007) explains in chapter 2 that school improvement depends on the active involvement of teacher leaders at the classroom level and beyond.

All the samples were of the view that educational leadership is about teachers as leaders assuming different roles within a school. The views of the respondents also clarified that leadership is about effective teaching and learning within the classroom. The researcher wants to assume that education leadership is about the leadership skills of teachers within the school and the distribution of leadership as leadership strategy is the skill of leaders to complete a leadership task through the leading and motivation to complete a task. A distributed leadership strategy that could be implemented as a leadership strategy is coaching of teachers to ensure effective schools. In chapter 3, Cope (2004) describes collaborative coaching “as a process of transference – whereby one person with prior knowledge or experience can impart his wisdom with a goal to optimise performance as a process of discovering where they help another person to reach full potential and to be capable to complete a task or a job at hand”. This distributed leadership tool will be discussed in chapter 5 at a later stage. The next theme that will be discussed is the distribution of leadership and teamwork to ensure effective schools.

5.4.2 Theme 2: Distributed leadership is about teamwork

The previous theme suggests that educational leadership is teachers as leaders with different leadership roles within the school. The theme under discussion is about distributed leadership and teamwork within the school. According to this definition, leadership is not a matter of passive status or of the mere possession of some combination of traits. It appears rather to be a working relationship among members of a group, in which the leader acquires status through active participation and demonstration of his capacity for carrying cooperative tasks through to completion (Hersey, Blanchard and Johnson, 2001) as discussed in chapter 2. This theme will give possible answers to the sub-question:- What are effective school leadership, leadership strategies and distributed leadership (as formulated in chapter 1)?

The researcher will refer to the clarification of types of distributed leadership as identified by MacBeath, Oduro and Waterhouse (2004) in chapter 2 in the summaries of this theme. Types of distribution are formal (with a job description);

pragmatic (indicated by necessity); strategic (when an individual's expertise is needed), opportunistic (based on people's preferences); incremental (based on previous performance) and cultural (when it promotes school culture).

SAMPLE A–Quotes from in-depth interviews

P1 HOD: Distributed leadership makes it very easy because then you have everybody involved first of all and they are all interested and apart from that <i>your</i> load is less. It is just then to make sure that what you get back is of a standard that is good enough but it definitely makes your task easier.
P2 DP: When we try to get the other teachers on board to make decisions. Otherwise, if you are going to prescribe to them and instruct them what to do, that is not what they must do and they are actually at grassroots level, they must do the job and if we prescribe to them what to do then you actually force them what to do. So, we would like to get their inputs as well so that we can have a nice team work effect here at this school.
P3 HOD: To think of the things that we have to do and then to give specific teachers specific tasks to do.
P4 CT: Well, if you have certain leadership skills in the class as such, I think it's very important that you don't just take the lead yourself; you need to channel those leaderships into the kids so they can become leaders as well.
P5 SJL: I think in some subjects in our school it has already been done meaning I think that each person in that group of subjects are responsible for a grade. I think that is what I understand so that it does not matter how much experience you have got, the Grade 6s are allocated to one teacher.
P6 P: You cannot do everything on your own. Some of the leadership you have got to cascade down or you have got to delegate down to your deputies and your HODs; that is why they are there. However, as the principal of the school, although I might distribute that leadership to other educators and management team members, I am still the one who is accountable and responsible for what is going to happen.

Management is of the view that all teachers are part of decision-making and their input will create an effect of teamwork (cultural distribution). Management will be still being accountable and responsible for tasks to be completed. Middle leaders add that all team members must be involved to complete a task and that responsibilities could be distributed to a level 1 teacher (incremental distribution). Class leaders explain that in the classroom teachers need to develop learners to be leaders as well (formal distribution).

SAMPLE B – Quotes from in-depth interviews

P7P: So, I believe that distributive leadership should identify people that will be able to perform certain management tasks. For example, the sports year calendar at our school was always managed by a head of department. This year I have made that a post level 1 educator's responsibility because sports are his passion. So, I am looking for where people show their talents, where their passion lies and then try to develop them as well by giving them management functions in their respective areas.

P8SJL: I understand that whatever my job is I can give you a section to do; then you are the boss of that section, because you have to see then that it works. And that somebody else can eventually can put things together again and see if it works.

P9 GL: I can give to my colleagues and I suppose the assistants also, the tasks that they will be able to handle. But I still have to monitor it, make sure that at the end of the day everything is in place and everything is done. So, I am then still responsible for the end product. But, time wise to win for myself.

P10 DP: It is distributing to not specifically one person, it can be to more people, with a continuous follow up. Obviously you cannot just hand something down and not follow up on it.

P11 and 12 CT and TA: CT: After a few years of teaching but later on you also use your younger teachers to give them certain responsibilities like in sport or even with some of the subjects or parts of the subject. You give some of the tasks to them with your supervision but give them also a chance to develop themselves.

TA: I think when you study at the university you only get that practical work, I think it is five weeks, I don't think it is each semester. That is not enough because you study for four years and then you are in this situation and you are not used to all the possible things that can happen and we as assistants see it every day and I think you get more normal experiences.

Management – distributed leadership is about identifying team members who are able to perform a certain management task (incremental distribution). Middle leaders – tasks could be handed to team members to complete (pragmatic distribution). Middle leaders will monitor if tasks are completed. Class leaders – give tasks to team members to complete as part of development to become leaders at a later stage in their careers (pragmatic distribution).

SAMPLE C – Quotes from in-depth interviews

P13 DP: Distributive leadership is using your subject heads or your grade heads involved in that subject. That is the same thing through your management in the school. I mean, the headmaster cannot do everything on his own. So, every head of department has got a job description and they must do a part of the work and then just report back to him.

P14 HOD: That I can use people working under me to do jobs for me. I distribute parts of the aspects of a job to them. I give certain aspects of a job to them and follow up to ensure that it is done correctly. That I don't keep everything to myself and do it all on my own. You cannot do that in this type of setup. I do not have subject knowledge in all the subjects. Therefore I will say to the math teacher give me guidance as to how your work needs to be done. The math teacher is in charge of the math books and the math standard and I accept what she tells me.

P15/16 CT and TA and CT: For me as a leader I can maybe share my ideas and work together with my other Grade 3 teacher. I will share my ideas with them and we will lead together. TA: We assistants always work together and if one is battling with a problem, we try and see how we can help one another as well. We will say maybe try this or try that. So, assistants definitely work together and then we work together with the teachers.

P17 SSL: As subject head of social sciences saying distributive leadership it is not that I am taking all my responsibility based on the people. In distributive leadership, you make it easier in one way to make sure that you are capable of achieving your goals that are set for you. If you have got too much work for yourself you are going to neglect some of the work, you are going to ration some of the things and some of the things that you are going to neglect are going to have a negative effect on the future of the educational side. Sometimes you think this is less important and now you neglect it and actually now it was the more important side of what are needed on the educational side. But, because you are restricted in your time and your abilities by doing everything yourself, you get to the point where you are burnt out and you will start forgetting things that are quite simple but have a big influence in the future. So, as a leader in that way you have to start looking at giving responsibilities to other people, get the stress levels of yourself down, but also to make sure that you stay positive in that way and that there are different views or different sides and sources to make sure that you have a better educational side.

P18 P: Well, distributive leadership is by giving responsibilities from your deputy principal to your HODs, to your senior teachers, and down to your level1 teachers. We want to see that there is an even load being given right through and we would like to give responsibilities to junior teachers as well so that they can develop in the process as well.

Management – management distributes leadership tasks to middle leaders for completion. However, dialogue must occur between leaders (formal distribution). Leadership tasks need to be given to level1 teachers also to develop leaders for the future (opportunistic distribution). Middle leaders – teamwork is about the acceptance of the expertise of other leaders to succeed in a leadership task (incremental and strategic distribution). Time management is for middle leaders.

Therefore, tasks need to be distributed to team members to achieve a goal within the department or grade (pragmatic distribution). Class leaders – sharing work with other class leaders to improve the quality of teaching and quality of teaching and learning (cultural distribution).

SAMPLE D – Quotes from in-depth interviews

P19 HOD: Nobody is an island. You have to work as a team. Once I have seen that they can do something I can delegate and get them to do the work. Nobody can do something on their own, so there has to be as structure; we have to be a unit.
P20 HOD: Initially to set an example I used to do the community outreach but there are staff members that are capable of doing that so they run that aspect now. So, I am kind of sharing that thing. Also building them and their leadership skills, which is important to the team I feel.
P21 CA: I think that is giving me more authority, giving me more tasks and leading like for instance saying ok you give this to them, showing them what they need to do. That would be distributing leadership.
P22 CT: Obviously I delegate a lot because, by the way, I used to be a scout and I have been a partial leader. I have found it very effective because we learned about leadership in the scouts, so when I come to the class I delegate someone who has to do the register and someone who has to do that etc. and everybody has to participate. In so doing, it might be small, but learners learn to be responsible and learn to use their skills, their abilities and to share it with the others. So, delegation is the best for everyone and they all feel important because they all take part in the learning.
P23 P: Distributive as the term says distribution, passing on leadership to others. In other words in my case, the head of department. I am the head of the school but my head of department of the primary school is running the primary school. She is in charge of all the academic stuff and she is in charge of all the academic stuff related to the primary school. I am distributing, passing my leadership on to that person, in other words delegating.
P24 CT: When you hand things over to other people like we have done in my phase because I cannot get on to the pre-primary school as much as I should. I have a mentor there, one of the older teachers that run it for me and she phones down to me when there is a problem. So, she is actually overseeing it for me because I cannot get up to preschool in the morning. That is what I would imagine; you are distributing the work load.

Management – teamwork is built on trust. Leadership tasks are distributed based on trust to capable leaders (opportunistic distribution). Middle leaders are charge of a phase or a grade (formal distribution). Middle leaders – skills building within teams are important for teamwork (incremental distribution). Class leaders – give to class leaders also responsibilities to lead on (opportunistic distribution). Effective class leaders will teach learners also to be team players within the class (cultural distribution).

SAMPLE E – Quotes from in-depth interviews

P25 P: Everybody is sharing it and everybody putting all of that together eventually to have one strong goal achieved.
P26 HOD: There are certain responsibilities I have but I know that at level 1 there are teachers that I work with who are more than capable of doing what I do. I think of how I became an HOD. I acted as an HOD for many years before I applied for the job and to me that was an absolutely wonderful thing because by the time I went for my interview for my job I knew exactly what was going on and what was expected of an HOD. So, I think it is a good thing to distribute.
P27 CT: Distributive leadership, I think, means that even though you are a leader you also need to motivate children to take part to delegate some of the activities to the children so that they feel part of the class or part of the lesson.
P28 CT: Distributive leadership. I would say it is about the same as democratic leadership or sharing. You give a bit and they give a bit. [Laughs] You have certain responsibilities; you share those responsibilities with the rest of them. So, you have like a pyramid and you give it down to them. You are still responsible for it but they also share in the responsibility in executing their tasks.

Management – to achieve a goal, all the leaders need to share and work together as a team (cultural distribution). Middle leaders – level 1 teachers part of the team. Use their skills to develop your own practice as leader (incremental distribution). Class leaders – motivate learners to become leaders and team players. Give them a leadership role within the class (opportunistic distribution). In this section, the researcher acknowledged the work of MacBeath, Oduro and Waterhouse (2004), as discussed in chapter 2, about the types of distribution that contribute to make schools more effective. The researcher also found a solution to the sub-question: *What are effective school leadership, leadership strategies and distributed leadership?* The table below will give an indication of how leadership are distributed within effective schools.

Table 5.2: Types of distribution within effective schools

Types of distribution	Sample					Total
	A	B	C	D	E	
Formal	1		1	1		3
Pragmatic		2	1			3
Strategic	1					1
Opportunistic			1	1	1	3
Incremental	1	1	1	1	1	5
Cultural	1		1	1	1	4

The researcher could that all the samples agree that incremental distribution is important for distributed leadership within effective schools. Most of samples agreed that cultural distribution is also important for distributed leadership to ensure effectiveness within schools. Samples of the samples agreed that formal, pragmatic and opportunistic distribution is also necessary to make schools more effective. Only sample C agreed that strategic distribution is necessary to ensure effectiveness within schools. The researcher will discuss theme 3 in the next section. Theme 3 focuses on distribution of leadership and interaction of leaders at all levels.

5.4.3 Theme 3: Distributed leadership is about democracy and sharing of leadership at all levels

The previous two themes discussed suggested that the role of distributed leadership is to ensure effective schools are about teacher leadership and teamwork. To ensure that teacher leadership and teamwork to be effective applicable leadership styles need to be link to the distribution of leadership to ensure effective schools. MacBeath, Oduro and Waterhouse (2004) explain in chapter1 that distributed leadership means the same as dispersed leadership, shared leadership, collaborative leadership and democratic leadership.

SAMPLE A – Quotes from in-depth interviews

P1 HOD: I normally have a committee, but I am quite autocratic in some way I suppose because I like to do things myself because I know what I want. When I get it back and it is not to the standard which I expect, then I have to redo it.
P2 DP: Personally I follow the democratic leadership style, but at some stage when there is no decision making from the staff, then we apply autocratic leadership skills and then we just tell the teachers what to do after management has come to a conclusion or tried to resolve a problem.
P3 HOD: Everybody must have an input, I am not in control. We will have meetings, we will discuss it, everybody will go back think about it, come back and if there is a decision to be made I will do that, but everybody needs to have an input.
P4 CT: I like to classify myself as 'the lion and the lamb', so it is very important to be the lion as such and to have discipline and to go through with the disciplinary actions that I have, but on the other hand, I like to be the lamb as well, that's me. I like to be the lamb, I like to love them; I like to make sure that they are happy in the class because happy kids are actually kids who excel in the classroom. That's me. So you will go more of the democratic way? Yes definitely.
P5 SJL: Now to take hours and hours to explain that to a teacher, I would then rather do it myself therefore being much too autocratic I think. [Laughs] I am supposed to delegate more but at this stage I am doing all the work and just telling the other teachers what to do.
P6 P: Most of the times you are going to be a leader which is more in the democratic leadership style, where you get all the role-players involved and you discuss the issue and you actually sell it to them and they must buy it. From time to time you also do get in a situation where you have got to be a very autocratic leader and say this will stop now and from now on this and this will happen and you actually have to spell it out. I have always used the definition that a good leader must be like a good piece of boerewors, there must be a bit of pink in it as well and then you will be a good leader. But to try and please everybody or most of the time please everybody is not going to work.

The data revealed that distributed leadership is about democratic leadership. However, in this sample it was clear that some of the leaders were under the impression that leaders needed to be autocrats and that they rather wanted to work on their own. The pie chart¹ below illustrates that 50% of the leaders are in favour that distributed leadership is about democracy with sharing of leadership.

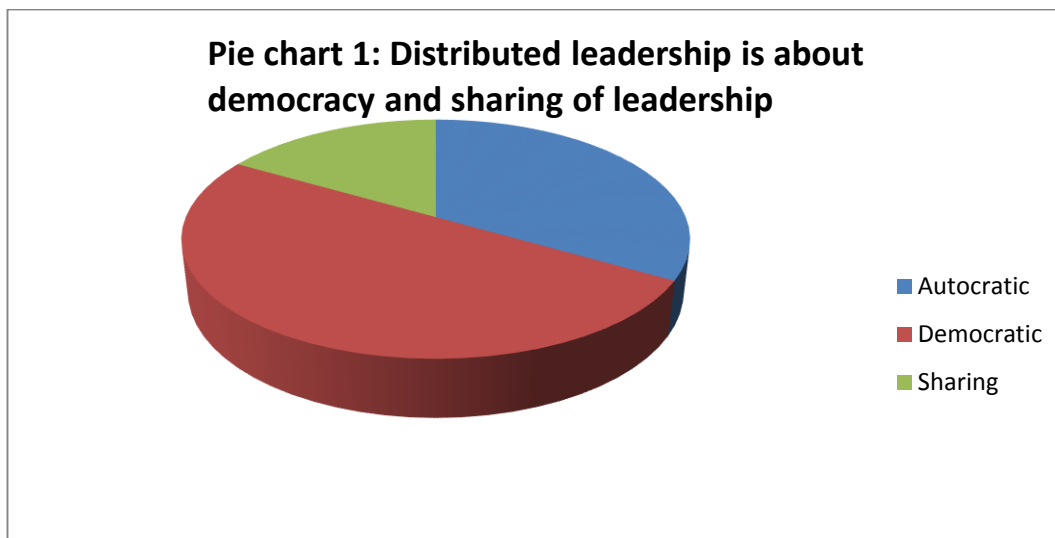

SAMPLE B – Quotes from in-depth interviews

P7P: Firstly, I believe in leading by example. Many times people ask me what do you do at school and I say I am the guy with the tie that picks up the papers! That is an example of a leader that people trace. I am willing to do what I expect from everybody in the school and also a leadership style as I said earlier, of cooperative management where every stakeholder is given his opportunity to set their point of view and then manage the final decision.

P8SJL: I am not a dictator as a leader. I prefer that we get together and discuss things and then get feedback. That is the type of leadership that I apply. So you are more a democratic type of leader? Yes.

P9 GL: Whatever there is to do, I go and plan it, go thoroughly through it and then we usually have a grade meeting once a week. I discuss it there with them and ask their input and then put it on paper and then we develop it. So, I always ask their opinion about it.

P10 DP: Well, everybody is a learner. Your teachers can still learn from your peers and from your superiors and I think that everybody should and by doing it as a team you always get some input from somebody that someone else did not think of.

P11 and 12 CT and TA: CT: Well, you must set the example and you must always be the same. So, you mustn't change from one. So, you are more the type of democratic leader? Yes, especially at the beginning of the year so that the children can get the example and then later on in the year as I said then I will not be so strict. TA: So, it is not that I just say this is right and that is right. You can just discuss it and talk about it. So, both of you then will use the democratic approach, the democratic style of working with each other and share ideas? Yes.

Table 5.3 illustrated that distributed leadership is about democracy and sharing of leadership tasks within the school. Pie chart 2 gives a clear indication that leaders agree that shared leadership is important when distribution of leadership tasks takes place.

Table 5.3: Distributed leadership is about democracy and sharing of leadership

Distributed leadership is about ...	Agreement
Autocracy	0
Democracy	3
Sharing	3

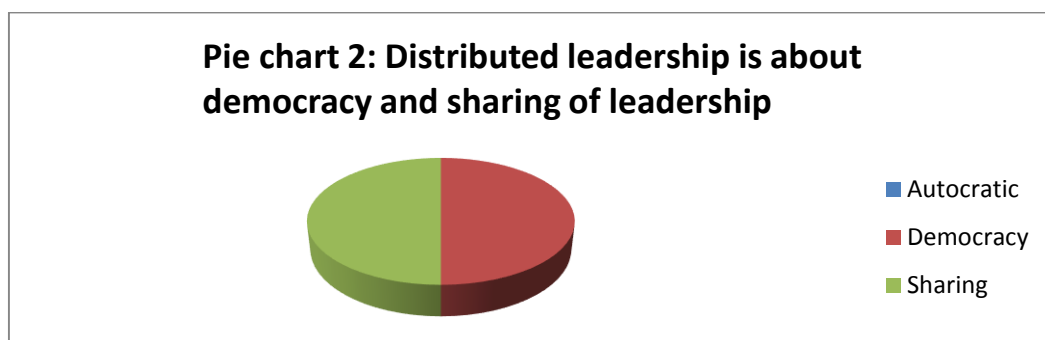

SAMPLE C– Quotes from in-depth interviews

P13 DP: So, basically to summarise it, you have a combination of shared leadership and democratic leadership? DP: Yes.

P14 HOD: Not autocratic. Not dictatorship. Advising leadership with giving help rather than disciplining. You need to be approachable. I am an approachable person. So you will go more for the collegial leadership? Yes, I do. With some sharing of leadership and democratic included with that? Yes, I do that.

P15/16 CT and TACT: We work together hand in hand and share ideas there too. If there is a difficult situation I ask her how she would deal with it and we would share ideas. TA: There are times if the teacher is not sure about something [not that I am always able to give an answer as I am not superior to her], but we definitely do work well together.

P17 SSL: So, to summarise that you like a combination of shared leadership and democratic leadership? SLSS: Yes, I would have a combination of that.

P18 P: I have an inclusive style where I make use of my management team to a great extent. Discuss matters with them. I am not an autocratic leader and I believe in sharing ideas and getting ideas from others and also getting input from the teachers. We are not afraid to go to the level 1 teacher and get their inputs in a matter as well. So, we think that the style of leadership is all inclusive.

Table 5.4: Distributed leadership is about...

Distributed leadership is about ...	Agreement
Autocratic	0
Democracy	3
Sharing	5

It emerged from the responses that leaders agreed that leadership needed to share with elements of democracy when leadership was distributed to ensure effective schools. The pie chart 3 below also indicates that distributed leadership is about sharing and democracy.

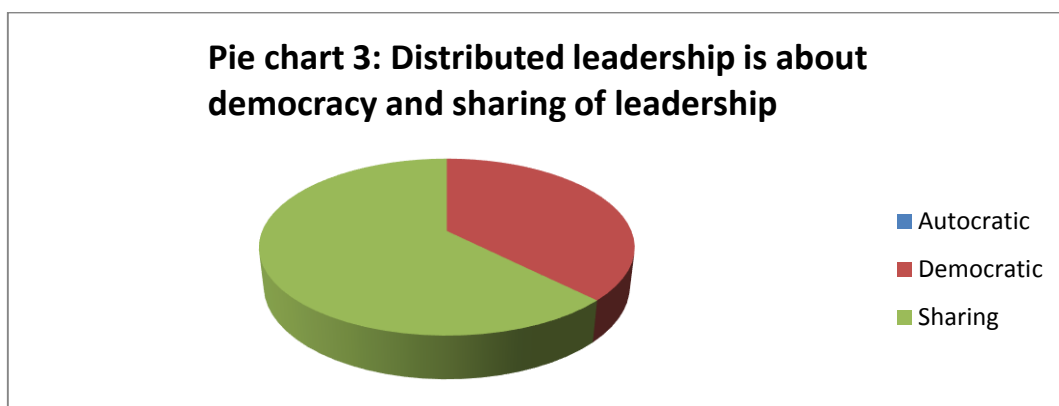

The data in table 5.4 and pie chart 3 revealed that sharing of leadership exists at schools. Teachers are able to make decisions in a democratic way. It was indicated that most teachers work together by sharing their experiences within the school. It emerged that most of the teachers are included in the process of making decisions.

SAMPLE D– Quotes from in-depth interviews

P19 HOD: I am saying that I am more of a democratic style leader.
P20 HOD: To summarise that, you are a leader who works as a democratic in the first place, but you also will share your leadership with others? Yes
P21 CA: Are more democratic
P22 CT: I am not too much autocratic a leader, but I like democratic in the way that allows learners to be themselves and learn from the group members so that they can take other people's opinions, learn from them and share leadership.
P23 P: So, you will basically apply then a style of democratic leadership with some forms of sharing leadership and instructional leadership to form the overall form of leadership that you will use on a day to day basis? Yes.
P24 CT: Yes, I think I am democratic.

Table 5.5: Distributed leadership is about...

Distributed leadership is about ...	Agreement
Autocratic	0
Democracy	5
Sharing	2

Table 5.5 shows that more than two-thirds of the schools are in favour of democracy as a leadership style at the school. Some teachers are of the opinion that sharing of leadership also contributes to the distribution of leadership within the school. The researcher also used pie chart 4 to illustrate the findings of the table.

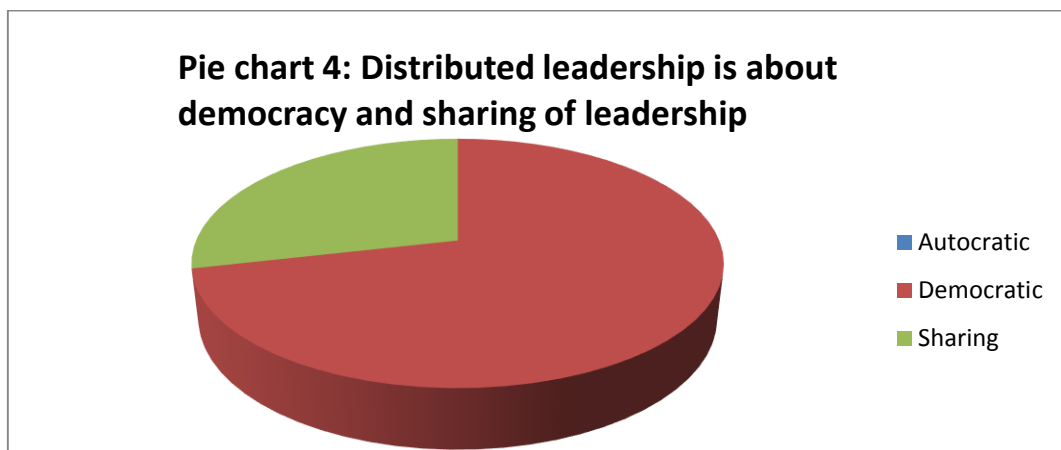

Pie chart 4 illustrates clearly that democratic decision-making is important for the distribution of leadership within the school.

SAMPLE E– Quotes from in-depth interviews

P25 P: So, basically to summarise in a nutshell; for you it is more a sharing type of leadership? Definitely.
P26 HOD: I would say I try to be democratic. I don't like to tell a teacher and I never will tell a teacher, "You do this and you do it my way and you do it your way."
P27 CT: I like to be democratic.
P28 CT: You will use some forms of democratic leadership styles? Yes.

It was found that most of the leaders at middle-leader and class-leader level followed a more democratic style of leadership when leadership tasks were distributed at the school. The leaders also felt that they were included in the process of making decisions to improve the school. Table 5.6 and pie chart 5

indicate clearly that 75% of the leaders are in favour of a democratic style of leadership when leadership tasks are distributed within the school.

Table 5.6: Distributed leadership is about...

Distributed leadership is about ...	Agreement
Autocratic	0
Democracy	3
Sharing	1

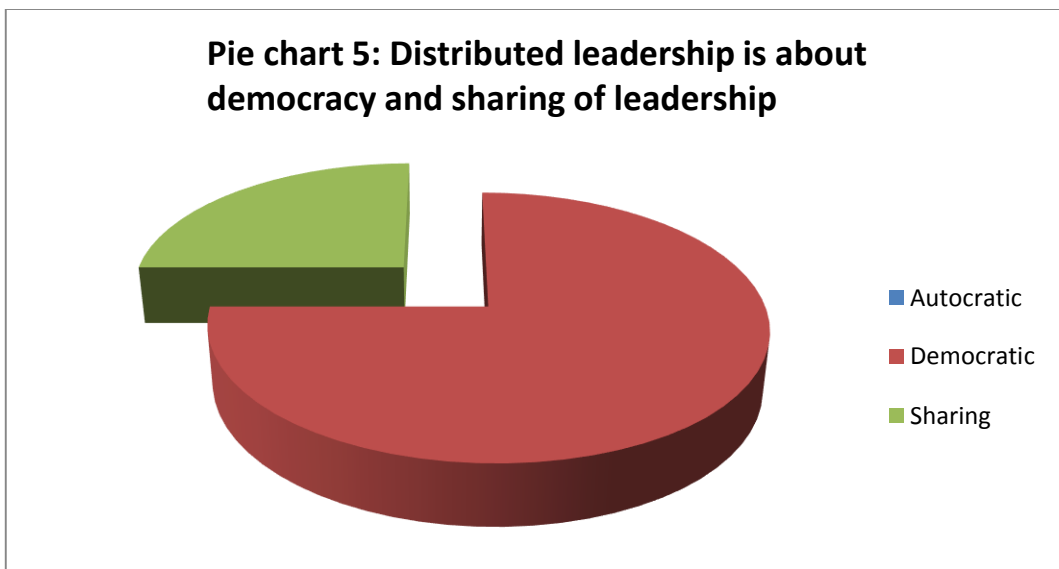

The researcher developed a table to identify a comparative viewpoint of how leaders view democratic and autocratic leadership as possible leadership styles when leadership are distributed within the school. Table 5.7 will give us a clearly conceptual viewpoint of distributed leadership within the school.

Table 5.7: Distributed leadership is about democracy and sharing of leadership

	Leadership styles		
	Democratic	Shared	Autocratic
A	3	1	2
B	3	3	0
C	3	5	0
D	5	2	0
E	3	1	0
Total	17	12	2

Table 5.7 was illustrated in pie chart 6 to form a comparative regarding the distribution of leadership within schools.

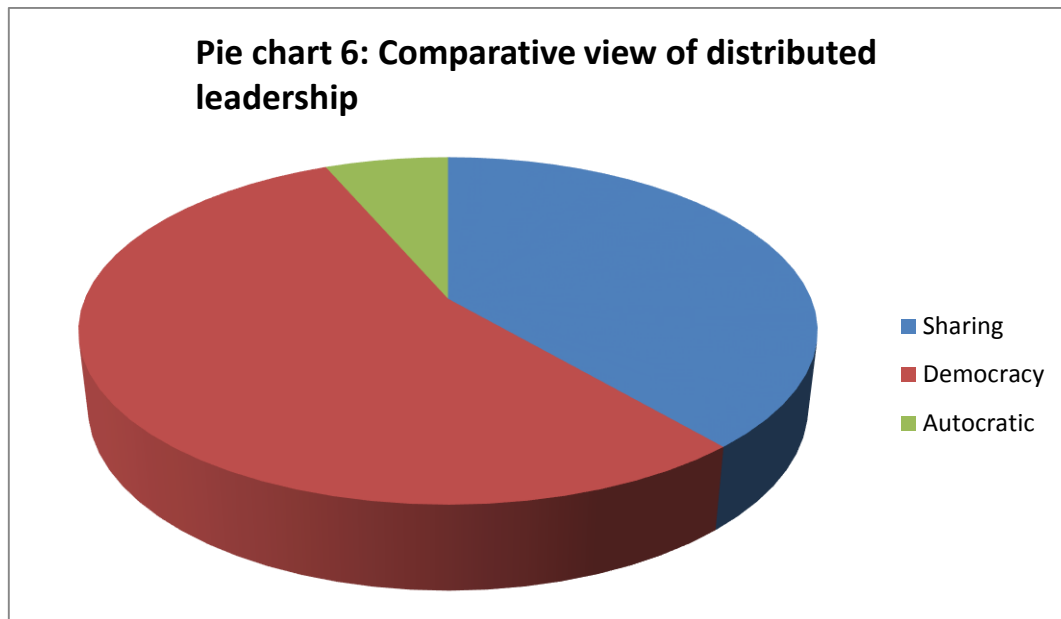

Pie chart 6 clearly illustrates that distributed leadership is about democracy with elements to share leadership tasks within the school. This theme also gave an idea of how distributed leadership support and improve schools. The interaction of leaders will be discussed as the next theme.

5.4.4 Theme 4: Distributed leadership is about interaction between all leaders

In the previous two sections, the researcher began to unfold the research problem: *The role of distributed leadership to ensure effective leadership within South Africa*. The researcher also found possible solutions to the sub-question: *What are effective school leadership, leadership strategies and distributed leadership?* The researcher discovered that teacher leadership is important to ensure effective leadership and that teamwork must be utilised as strategy to ensure effective. In this theme, the researcher want to discuss how distributed leadership support and improve effective schools as discussed in chapter 2.

The aim of the researcher was to find out through this theme if coaching could be used as distributed leadership strategy to ensure effective within South Africa. This should also offer possible solutions to the sub-question: *How can coaching be used as a successful and effective distributed leadership strategy?* as discussed in chapter 3. The researcher made use of diagrams to illustrate the interaction of leaders at all levels.

SAMPLE A – Quotes from in-depth interviews

P1 HOD: I think it is about people skills. If you don't have a good personal relationship with the people at your school you are not going to get any jobs out of them anyway. Your personal relationship with them must be good. Your people skills must be good. How do you contact them, how do you ask them to do things.
P2 DP: OK, there is always room for improvement, but at this stage the teachers are working together quite effectively. They have mutual respect for one another. They show loyalty to one another and we share the same goal. The same goal is the learners. So, everybody is going in the same direction.
P3 HOD: In our junior primary phase we work really well and we are still motivated.
P4 CT: So, the suggestions that I make, if there is anything that worries me sometimes you have to be very careful and handle that according to the person. Sometimes they don't like to be reminded about what they should be doing or the structure should be changed, because that's the way they feel.
P5 SJL: I don't experience that people are willing to share but they are still, I think some of them are very scared.
P6 P: It's always a situation of two heads is better than one and if you can have good team work it will always be a very good outcome. But you must always remember that your team is as strong as the weakest player in the team.

Aditja (1997) explains in chapter 1 that distributed leadership is the process of leadership, which involves collaborative relationships that lead to collective action grounded in the shared values of people who work together to effect positive change. Carson, Tesluk and Marine (2007, see chapter 2) that managers should encourage each member of the team to demonstrate leadership through personal meetings. During these meetings, they should encourage this person to utilise their strengths, provide clarity and offering support and advice. These practices are effective, because a supportive coaching environment is the principal characteristic of shared leadership. Diagram 1 below indicates that leadership is developed through teamwork, shared leadership and interaction of leaders.

Diagram 1: Distributed leadership is about the interaction of leaders at all levels

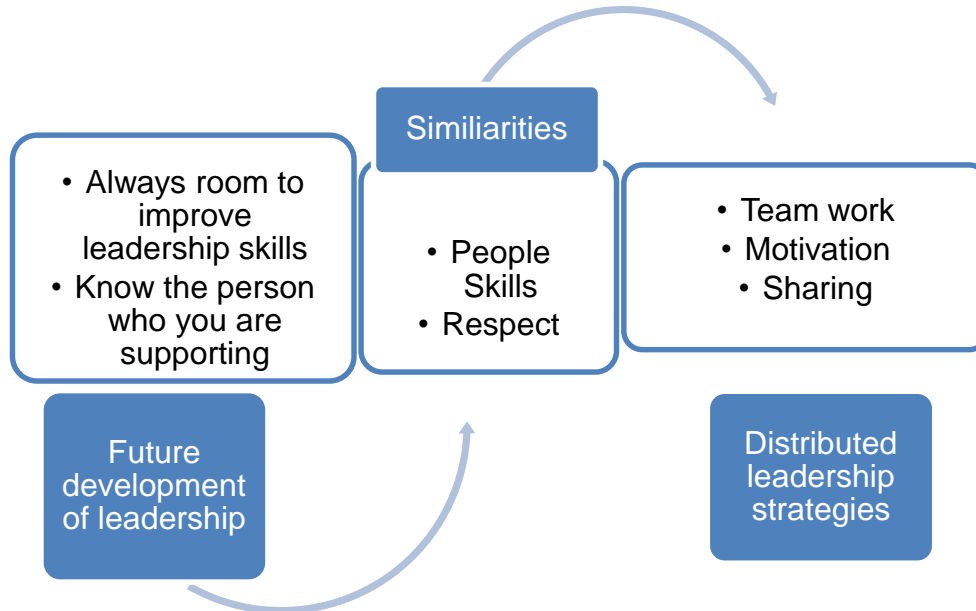

Distributed leadership is about teamwork and sharing of leadership within the school. There are always opportunities to improve leadership skills. In this study, leadership skills will be improved by the implementation of the Oscar coaching model to facilitated meetings as a distributed leadership strategy. This will be discussed in more detail in chapter 6 (findings and recommendations) of the study.

SAMPLE B – Quotes from in-depth interviews

P7P: I think for professional support and professional motivation and encouragement it is necessary for educators to close ranks and motivate one another. I know that specifically our school motivates and is a source of inspiration for the teachers, due to the fact that we are still able to start collectively with scripture reading and prayer as a unit in the mornings. Another thing which I believe for motivational encouragement is positive feedback. We keep our staffroom as a positive environment where the policy is in the staffroom and in the public environment everything is positive, but when there is a complaint or a negative thing it is brought to this office and we take it here, so that outside we look strong and good but inside we take the problems on a one to one basis.
P8SJL: We must have a heartbeat for our subjects. I feel that that is very important. Sometimes subjects are just allocated because there is a need for somebody to do that subject and present it in the class. Now you must still go and sit down with that person and ask, "Are you willing to do the subject?" If you don't find it stimulating yourself, how on earth are you going to make it interesting for your children? So, I see it in that way.
P9 GL: 'It is a will in yourself to do what is asked from you. If you don't want to work with the rest then you will fall out and it won't work.
P10 DP: Well, everybody is a learner. Your teachers can still learn from your peers and from your superiors and I think that everybody should and by doing it as a team you always get some input from somebody that someone else did not think of.
P11 and 12 CT and TA: Yes, you learn to get to know her better. Not personal like I would say, but her personality and all that and then you can work together and you get to know this lady and her teaching skills and where she comes from and her experience and all that.

Diagram 2: Distributed leadership is about the interaction of leaders at all levels

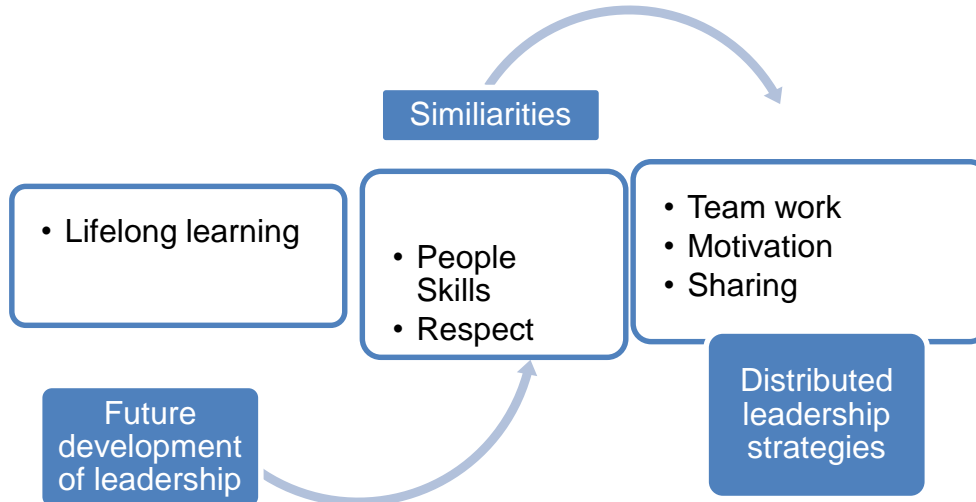

In chapter 2, the researcher referred to Warman and Jackson's (2007) explanation that improvements in sharing of practice seem enhanced by a group approach to peer support – since work discussion groups involve several practitioners working together over time, the capacity for peer consultation between colleagues develops not only within the group, but also outside the work discussion groups too. According to Clutterbuck (2001, see chapter 3), coaching is effective when it focuses on skills and performance and it is the role of the line manager to coach and give feedback after the discussions. Coaching as distributed leadership strategy through the Oscar coaching model to facilitate meetings will be discussed in more detail in chapter 6 of the study.

SAMPLE C – Quotes from in-depth interviews

P13 DP: Well, at our school I think it is the case, because some of our teachers that teach the same subject will sit together and do the planning together. I think all the children benefit from that because your weaker teacher can learn from the other ones. They can guide one another in the group. I think in my case it is because they know me for years and they know that if I don't know the answer I always try and help them to get the answer. I think that gives them that assurance that there is somebody else that will try and help them. I always walk the extra mile.

P14 HOD: I am approachable. They are not afraid of me. They are not afraid to differ in their opinions. They are not afraid to ask me something or to tell me something. I am in the very privileged position that the young ones who work under me in the language department are all children whom I taught at this school and it is nice that they have come back.

P15/16 CT and TA: CT: I would say constant communication and it must be open. You mustn't be offended if the teacher comes to me and feels that there is something that I am doing wrong. I must take it as discipline that she is helping me; she is not degrading me; she is helping me. That is how I would see it. TA: I have learnt a lot from the teachers through the years that I have been here and I have learnt a lot from the way how I would think to handle it but then I have learnt from the teacher's perspective to handle it in that way.

P17 SSL: As subject head of social sciences, we try to have at least one meeting every term. At the beginning of the year we normally have quite a long meeting where we discuss what our plans for the year are, what we are going to try and achieve with the learners and to make sure that we have an open relationship. As subject head the teachers working with me know that I have got an open door policy. At any stage that they might have problems or whatever, they know they can discuss it with me; they are welcome to come and speak to me. I often in my lessons where I have got off time if I need to come down to the office some days I will take my route in such a way that I can walk past these teachers' classes and just hear what they are busy saying and doing in their classes so that I am on the same track as where they are at this stage.

P18 P: I think if teachers work together as a team, if you just look at one aspect regarding discipline. If they are not speaking from the same mouth regarding discipline then you are going to have a problem with discipline. You need to work together with everyone in order to get a system going that is working. And on the academic side? We need to speak from the same mouth and work from the same guidance that the Department gives us in the form of syllabus work and that is why we have subject meetings and that is why we have grade meetings so that we can go forward by doing the same thing; by looking at academic aspects from the same background and from the same viewpoint.

Ritchie & Woods (2007, see chapter 2) explain that the distributed leadership model involves distributing responsibility at all administrative levels, working through teams, and engendering collective responsibility. Lambert (2005, see chapter 2) states that principals need to hand decisions and problem solving back to the teachers, coaching and leading for teacher efficacy while refusing to hold tight to authority and power. This is possible through the interaction of all leaders while leadership tasks are distributed. According to Gilbert and Whittle (2009), any meeting that involves discussion, problem solving and action planning, creates an opportunity for group coaching.

The researcher will discuss the implementation of the Oscar coaching model to facilitate meetings in more detail in the findings and recommendation of this study.

Diagram 3: Distributed leadership is about the interaction of leaders at all levels

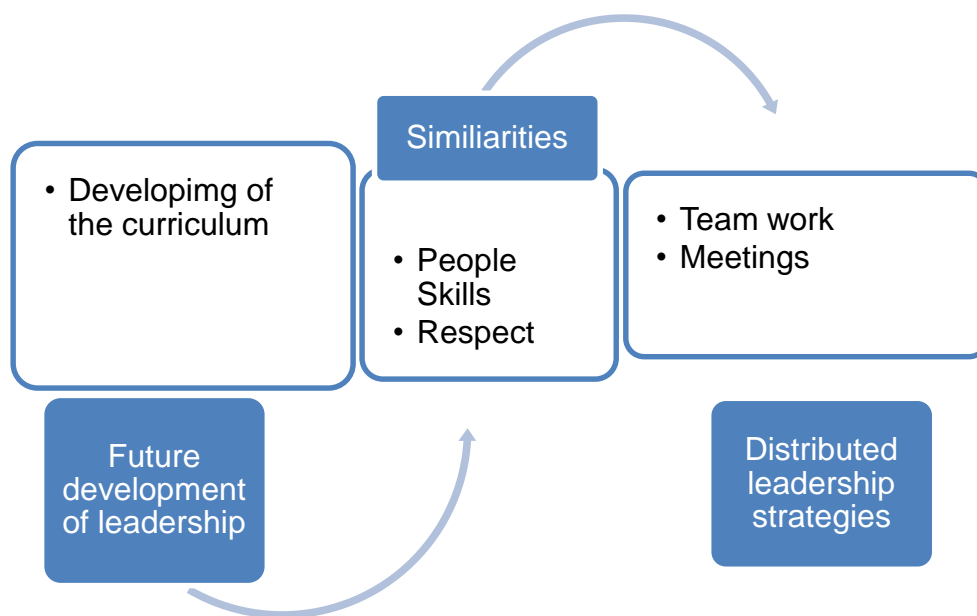

SAMPLE D – Quotes from in-depth interviews

P19 HOD: I think probably because we are all on the same page, so, if we have common goals, then those learners will have common goals. Most of our subjects are inter-linked; so, for example, we could do something in maths that can help the English.
P20 HOD: With the staff I encourage one-on-one meetings. Then obviously I go to them and say hello, how are you are you having a good day? Same with the children, I have meetings, but now what I have done because I feel the time frame is so limited and I can't get to all the children, so I put mentors in place and they come and report to me if a child is not doing well and there is a problem and things like that.
P21 CA: I think being honest with one another. We have got that relationship that if I am doing something wrong she can come to me and say, "Listen, rather do this." Just an understanding of one another, a respect for one another and it's a friendship. I work well with her, she is wonderful and she has been good to me and I know my place and I can learn from her. It is a friendship for me more than anything.
P22 CT: First of all, communication, if the communication is improved. From my perspective it is a matter of understanding what somebody is saying, not only talking but understanding that interaction and having one goal. Having one vision, knowing that this is what we are doing. They might be short-term goals, not long-term goals, but we know exactly what we are up to as a school. We push in sport, we do that as a team, we put that spirit in our learners and we just do that as a school. So, in that way communication plays a major role and then obviously supporting one another and helping one another.
P23 P: Openness. Me, personally, I have an open-door policy and at the beginning of each year I say to the staff, "Guys, I am not perfect; we are in this game together. If there is something that you don't like that I am doing, tell me. Its constructive criticism because you might pick up something that I am not picking up but don't talk behind my back and say he should have done this and that. Come to me openly and say, 'Sir, maybe we should try this'." That openness to me encourages people forward and getting involved because it is our school, it is not my school. It is our school.
P24 CT: Well, when there is a new teacher, like we got a new Grade 2, then the one who has been here a while, I get her to monitor the new one and then they work together as a team.

Diagram 4: Distributed leadership is about the interaction of leaders at all levels

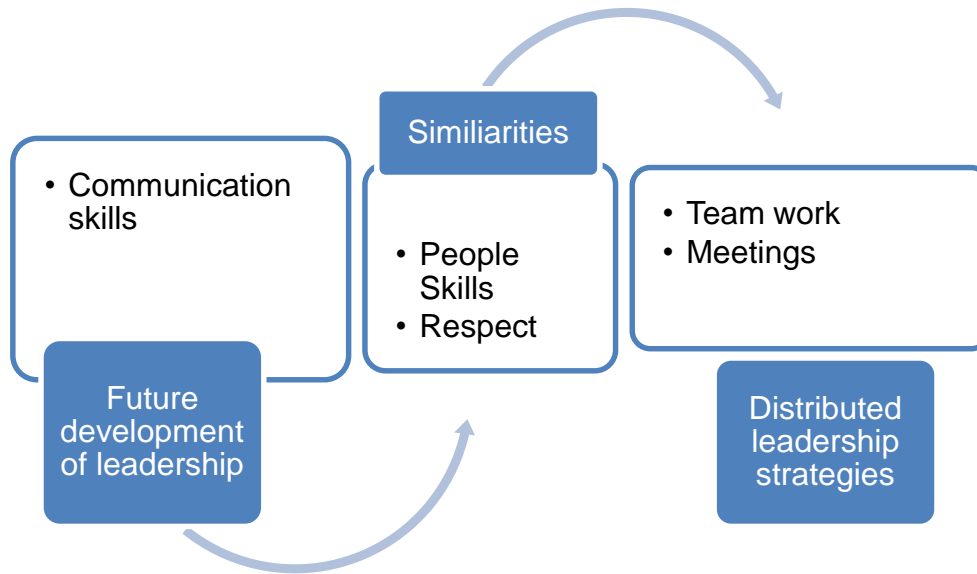

Gilbert and Whittleworth (2009:96) explain that the benefits of well-managed meetings will:

- save time, improve motivation;
- create opportunities for better decision-making;
- resolve problems quicker;
- build stronger and more productive working relationships;
- establish meetings that involve the entire team;
- encourage participation and responsibility of all team members; and
- ensure that there are fewer meetings where the leader tells, instructs and make all the decisions.

The Oscar coaching model to facilitate meetings as distributed leadership strategy will be discussed in more detail in the findings and recommendations of this study.

SAMPLE E – Quotes from in-depth interviews

P25 P: Well, collaborative definitely. I think that is the collegial and collaborative teaching and that is what I usually say we do at this school. The more you are together, the better things happen, because everybody is together and on board with the same train, knowing exactly where we are aiming at.

P26 HOD: I believe that communication is the best way to improve anything. We work very much in grade groups in this school. So, what you will find is your grades form these little groups. So, you're Grade 4 teachers and your Grade 5, 6 and 7 teachers, because we all meet on a weekly basis, problems are discussed at those meetings on a weekly basis. Notes are also kept and we have a book where we have to write down all the planning for the week. In that book is also written any problems and on a Monday morning that book gets handed in. So, it is a lovely place where they can write any comments, any problems that they have got and it is sort of like a communication thing as well. I can write comments like, 'Come and see me', or 'Let's discuss this,' or whatever. So, we do it through that book to a certain extent.

P27 CT: So, if you share with other teachers 'how do you try to deal with these problems' then your work load or the problems that you encounter become light so the burden that we have becomes less. So, the more we interact or as we work together I think we share ideas on how to deal with certain problems.

P28 CT: Last year I had a student that took EMS for the Afrikaans class, so I don't have anything to do with them, but we worked together to form, we have to basically have the same standards.

Coaches can distribute leadership by means of careful contracting. It takes skill to create a trusting environment in which open dialogue can occur and underlying issues be brought to light. A great deal of honest communication and feedback will set the parameters of the executive coaching process. The objectives of the 'contracting dialogue' should include the following: (1) identified success factors for a specific executive's (or team's) current and potential role; (2) agreement on confidentiality boundaries; (3) identification of specific expected business results; and (4) confirmation that the 'chemistry' is right to build trust and rapport (Freas, 2000). Danielson (2007) explains that school improvement depends on the active involvement of teacher leaders at classroom level and beyond. At every school, teacher leaders can find numerous opportunities to extend their influence beyond their own classrooms to the department or teaching team across the school and beyond the school. (See chapter 2, p. 49.)

Diagram 5: Distributed leadership is about the interaction of leaders at all levels

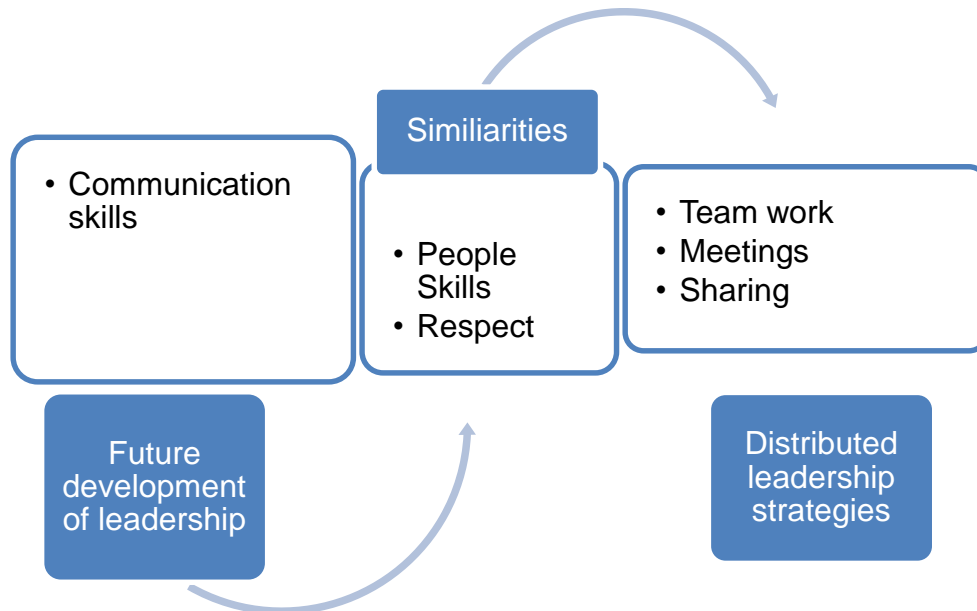

Chapter 1 clarified that distributed leadership is the process of leadership, which involves collaborative relationships that lead to collective action grounded in the shared values of people who work together to effect positive change? In chapter 2, it emerged that managers should encourage each member of the team to demonstrate leadership through personal meetings. During these meetings, they should encourage this person to utilise their strengths, provide clarity and offering support and advice. These practices are effective, because a supportive coaching environment is the principal characteristic of shared leadership. Coaches can distribute leadership by means of contracting carefully. It takes skill to create a trusting environment in which open dialogue can occur and underlying issues can be brought to light. A great deal of honest communication and feedback will set the parameters of the coaching process.

The researcher also decided that the Oscar coaching model to facilitate meetings would be implemented as a leadership strategy to ensure effective schools.

5.4.5 Theme 5: Distributed leadership is about sharing of leadership and not the delegation of leadership

Hafford-Letchfield, Leonard, Begum and Chick (2007) explain that coaching has a strong link with action learning, because coaching focuses on problem solving and the continuous process of learning and reflection. Reflective practice is important because it encourages us to take responsibility for ourselves, our learning and for our own actions. It encourages continuing personal and professional development, discourages blame and encourages creativity, problem solving and continuing aspirations to raise quality and standards. Stone (2007) maintains that managers master the skill of coaching find that it can boost the performance of workers by making clear to them what they should do and how they should be do it (think instruction), positively reinforce good work (think praise) and find ways to redesign jobs or increase employee contribution (think empowerment or shared leadership). This theme will give more evidence of how the implementation of a coaching model can be used as an effective and successful distributed leadership strategy.

SAMPLE A – Quotes from in-depth interviews

P1 HOD: distributive leadership is the responsibility or jobs of the principal and his deputy which they distribute to other people.
P2 DP: Each teacher has some responsibility from the start and that the principal or deputy head teacher coordinates in ways that make the sharing of leadership more important.
P3 HOD: Distributive leadership is the responsibility or jobs of the principal which they distribute to other people.
P4 CT: Both ways.
P5 SJL: Each teacher has some responsibility from the start and that the principal or deputy head teacher coordinates in ways that make the sharing of leadership more important.
P6 P: Each teacher has some responsibility from the start and that the principal or deputy head teacher coordinates in ways that make the sharing of leadership more important.

Table 5.8: Sharing versus delegation

Sharing versus delegation	
Sharing	3
Delegation	4

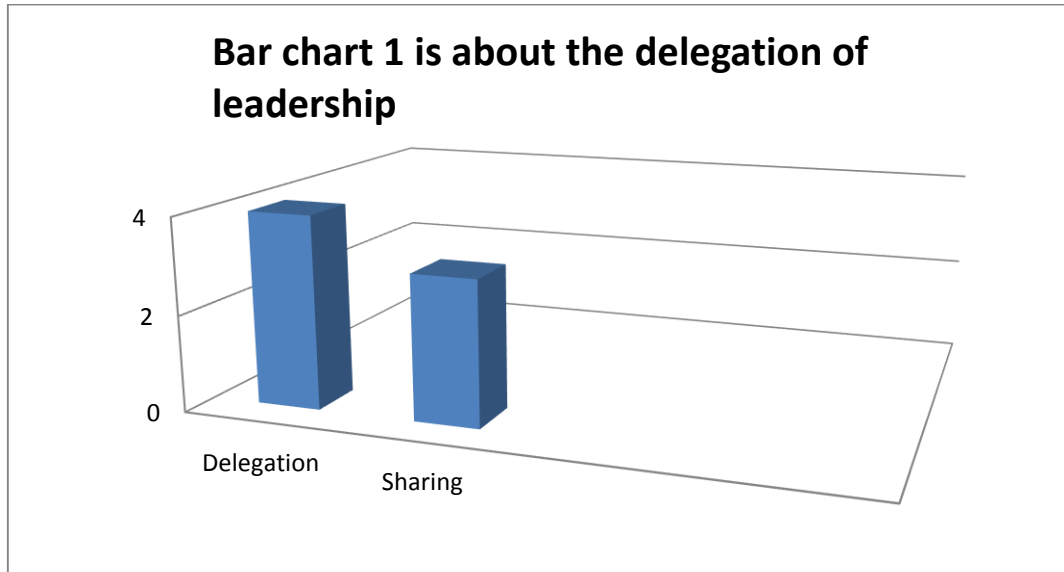

Table 5.8 and bar chart 1 give evidence that distributed leadership is about delegation. This emerges from the responses from sample A. Harris (2005) explains that it is important to distinguish between distribution of leadership and delegation of leadership tasks. He holds the view that it is a misunderstanding to assume that distributed leadership means to delegate certain tasks. Distribution of leadership is not delegated leadership. Distribution of leadership describes a process where distributed leadership is the by-product of shared leadership activities, discussion or dialogue rather than the routine handing out of tasks. Distributed leadership is concerned with two things – the process of leadership of how leadership occurs within the organisation and leadership activities of how leadership is enhanced and developed within the organisation. Cope (2004) describes collaborative coaching as a process of transference – whereby one person with prior knowledge or experience can impart his wisdom with a goal to optimise performance as a process of discovering where they help another person to reach his or her full potential and to be capable to complete a task or a job at hand.

The collaborative nature of the seven-stage framework is important, because the two drivers of coaching, “help someone” and “help themselves”, come together at the midpoint on the coaching continuum.

SAMPLE B – Quotes from in-depth interviews

P7P: Both ways.
P8SJL: Each teacher has some responsibility from the start and that the principal or deputy head teacher coordinates in ways that make the sharing of leadership more important.
P9 GL: Each teacher has some responsibility from the start and that the principal or deputy head teacher coordinates in ways that make the sharing of leadership more important.
P10 DP: Each teacher has some responsibility from the start and that the principal or deputy head teacher coordinates in ways that make the sharing of leadership more important.
P11 and 12 CT and TA: Each teacher has some responsibility from the start and that the principal or deputy head teacher coordinates in ways that make the sharing of leadership more important.

Table 5.9: Sharing versus delegation

Sharing versus delegation	
Sharing	6
Delegation	1

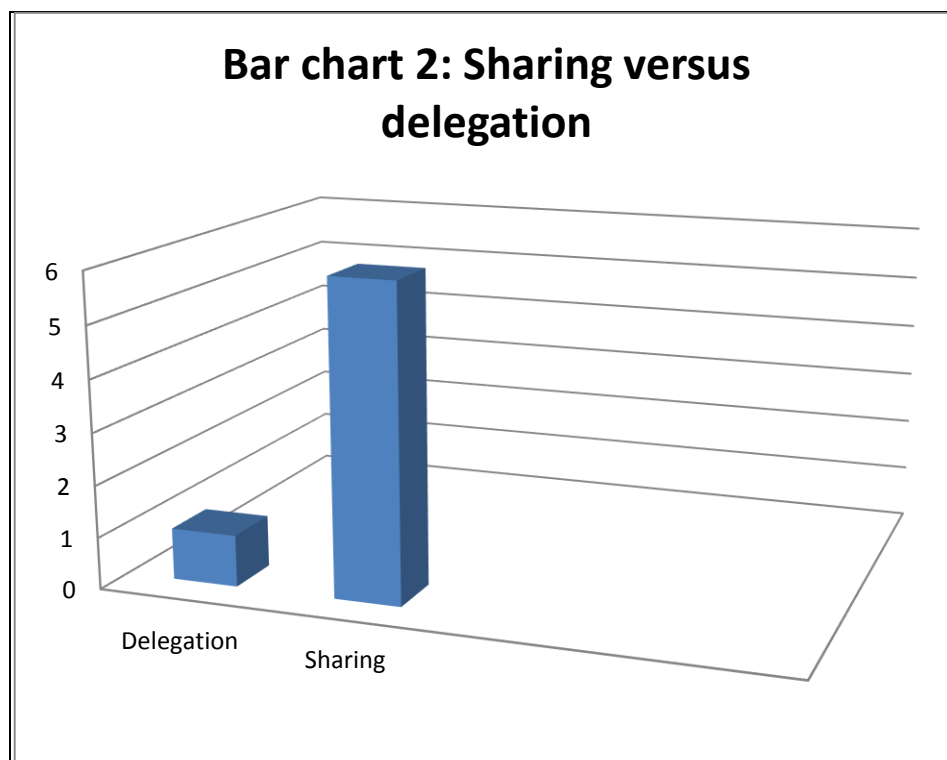

Table 5.9 and bar chart 2 supports the view of the respondents that distributed leadership is about sharing of leadership and the delegation of leadership.

Spillane, Halverson and Diamond (2001) assert that distributed leadership cannot be delegated.

Delegation is a manifestation of power relationships. Expansion of leadership is about empowerment – opportunity, space, support, capacity and growth. Jobs and tasks are delegated (passed down a managerial structure) but leadership is invitational. Whitmore (2002) recommends that team coaching follows the same guidelines as coaching individuals, so that the objective should be to accentuate not only mutual team awareness, but also to heighten individuals' perception. The implementation of the OSCAR coaching model to facilitate meetings can be utilised as a leadership strategy to ensure effective schools. A discussion will be given in chapter 6 on the implementation of the OSCAR coaching model.

SAMPLE C – Quotes from in-depth interviews

P13 DP: Distributive leadership is the responsibility or jobs of the principal which they distribute to other people.
P14 HOD: Each teacher has some responsibility from the start and that the principal or deputy head teacher coordinates in ways that make the sharing of leadership more important.
P15/16 CT/CA: CT: Distributive leadership is the responsibility or jobs of the principal which they distribute to other people. CA: each teacher has some responsibility from the start and that the principal or deputy head teacher coordinates in ways that make the sharing of leadership more important.
P17SSL: Each teacher has some responsibility from the start and that the principal or deputy head teacher coordinates in ways that make the sharing of leadership more important.
P18 P: Each teacher has some responsibility from the start and that the principal or deputy head teacher coordinates in ways that make the sharing of leadership more important.

Table 5.10: Sharing versus delegation

Sharing versus delegation	
Sharing	4
Delegation	2

It emerges from Table 5.10 and bar chart 3 that most of the respondents are in consensus that the distribution of leadership is about sharing and not delegation. Harris (2005) explains that distribution of leadership describes a process where distributed leadership is the by-product of shared leadership activities, discussion or dialogue rather than the routine handing out of tasks. The coach

and the client will discuss what has happened, what is happening, and what the client wants to happen (Copeland, 2004).

Coaches can distribute leadership through teams and collective responsibility. Ritchie and Woods (2007) explain that the democratic and distributed leadership model is similar in some ways to the distributed leadership model, which involves distributing responsibility at all administrative levels, working through teams, and engendering collective responsibility (par 2.6).

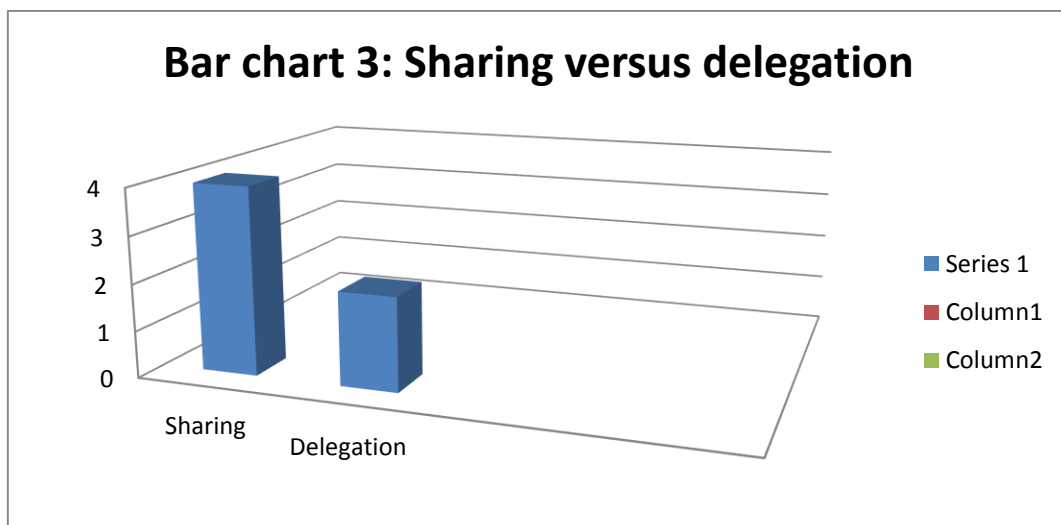

SAMPLE D -Quotes from in-depth interviews

P19 HOD: Each teacher has some responsibility from the start and that the principal or deputy head teacher coordinates in ways that make the sharing of leadership more important.

P20 HOD: Each teacher has some responsibility from the start and that the principal or deputy head teacher coordinates in ways that make the sharing of leadership more important.

P21 CA: Each teacher has some responsibility from the start and that the principal or deputy head teacher coordinates in ways that make the sharing of leadership more important.

P22 CT: Each teacher has some responsibility from the start and that the principal or deputy head teacher coordinates in ways that make the sharing of leadership more important.

P23 P: Both.

P24 CT: Each teacher has some responsibility from the start and that the principal or deputy head teacher coordinates in ways that make the sharing of leadership more important.

Table 5.11: Sharing versus delegation

Sharing versus delegation	
Sharing	6
Delegation	1

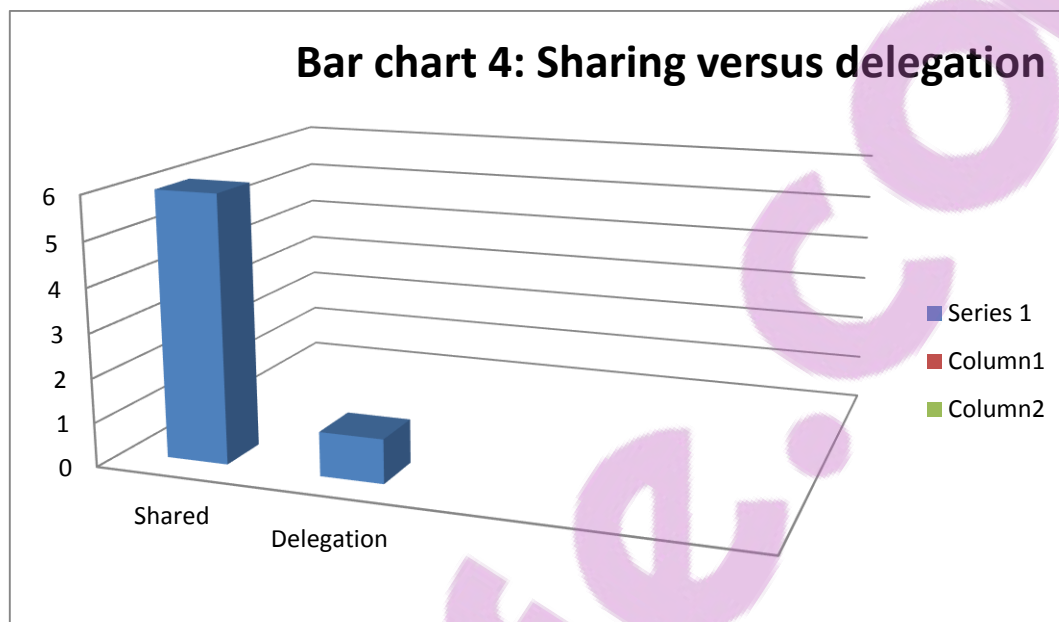

More than 85% of the respondents were in an agreement that the distribution of leadership is to share leadership responsibilities to achieve an organisational goal. Table 5.11 and bar chart 4 supports the statement. Manz and Sims (1991) suggest a form of leadership that is expected to exceed the individual heroic model. New models of leadership recognise that effectiveness in the workplace depends less on individual, heroic action and more on collaborative practices distributed throughout an organisation. Clutterbuck (2001) explains that coaching is primarily a short-term intervention aimed at performance improvement on developing a particular competence. The competence of teaching staff will ensure that schools are more effective. The researcher wants to assume that the implementation of the OSCAR coaching model to facilitate meetings will support schools to achieve an educational goal and this goal refers to the improvement of teaching and learning.

SAMPLE E – Quotes from in-depth interviews

P25 P: Each teacher has some responsibility from the start and that the principal or deputy head teacher coordinates in ways that make the sharing of leadership more important.

P26 HOD: Each teacher has some responsibility from the start and that the principal or deputy head teacher coordinates in ways that make the sharing of leadership more important.

P27 CT: Each teacher has some responsibility from the start and that the principal or deputy head teacher coordinates in ways that make the sharing of leadership more important.

P28 CT: Each teacher has some responsibility from the start and that the principal or deputy head teacher coordinates in ways that make the sharing of leadership more important.

Table 5.12: Sharing versus delegation

Sharing versus delegation	
Sharing	4
Delegation	0

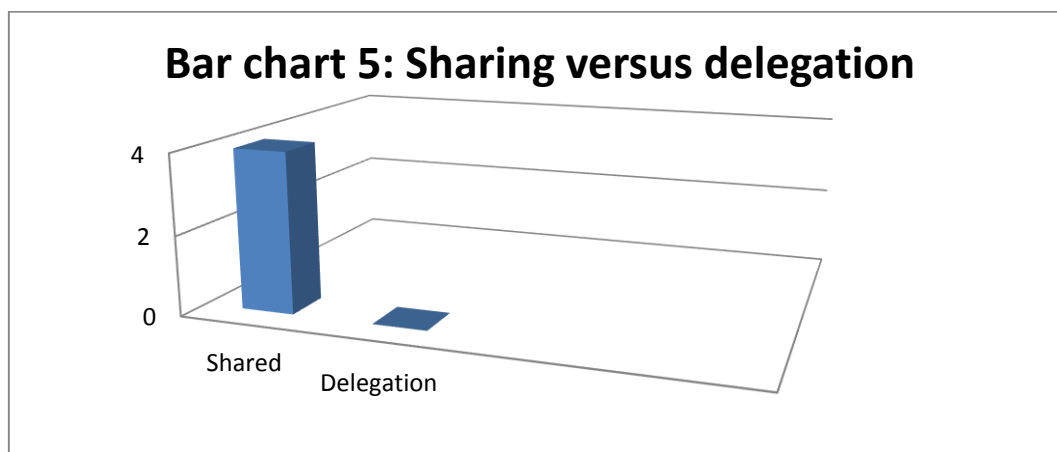

All the respondents agreed that distributed leadership was about sharing leadership and not delegation of leadership (table 5.12 and bar chart 5). The National Quality Schools Framework in Australia (Department of Education, Science and Training, 2003) explains that schools with shared leadership as leadership strategy can empower staff to share leadership for school development that responds to and manages the processes that lead to sustained improvement. The idea of “**Cockpit confirmation**” (C5) is an effective tool for

the client to monitor own progress and measure level of achievement (Copeland, 2004).

Distributed leadership is a form of shared leadership that is distributed to key stakeholders throughout the organisation. The researcher here refers to The National Quality Schools Framework in Australia (Department of Education, Science and Training, 2003), which proposes that schools with shared leadership as leadership strategy can support and monitor professional learning by means of distributed leadership and develop and maintain high-level shared knowledge about curriculum and instruction.

Twenty-two respondents were in favour of shared leadership as a strategy for the distribution of leadership. 73% of all respondents were in favour of shared leadership as a distributed leadership strategy to ensure effective schools. However, eight respondents explained that distribution of leadership is more about the delegation of powers to leaders. This can be illustrated as follows in a bar chart 6.

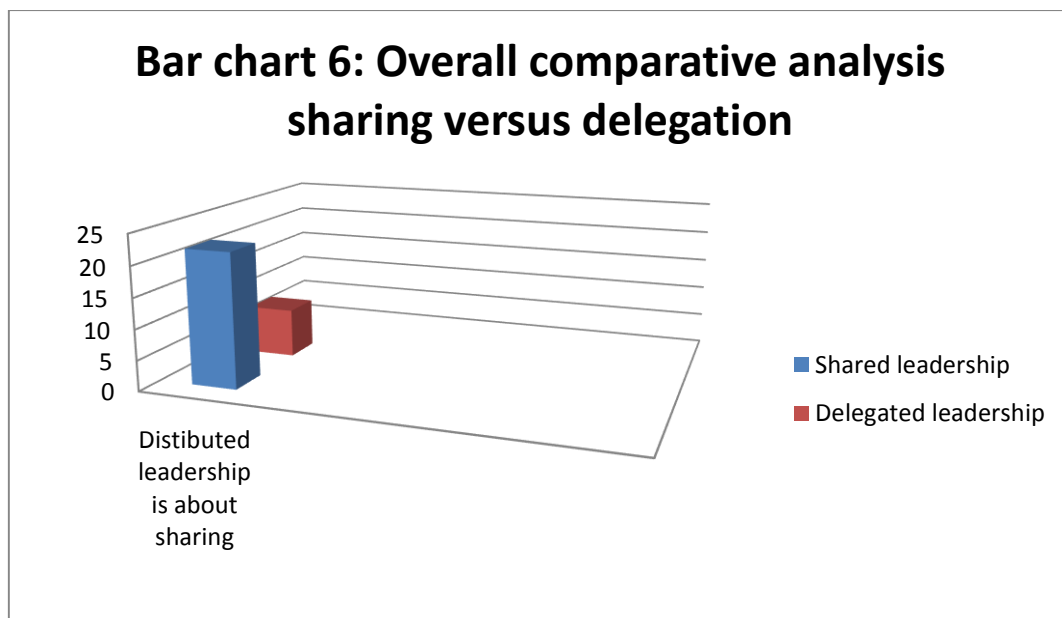

The researcher discussed in this theme whether the distribution of leadership is about sharing or delegation of leadership to ensure effective. It was evident that most of the respondents were in favour of each teacher has some responsibility

from the start and that the principal or deputy head teacher coordinates in ways that make the sharing of leadership more important.

The researcher also gave evidence how sharing of leadership through coaching can improve a school further. The researcher will explain in the next theme whether the distribution of leadership in South Africa can ensure more schools that are effective.

5.4.6 Theme 6: Distributed leadership is about ensuring effective schools in South Africa

The major research problem under investigation is the role of distributive leadership as strategy to ensure effective schools in South Africa. The researcher formulates the research question: *Do you think that we can use the distributed leadership approach to ensure effective schools in South Africa? Why?* The researcher developed the theme: *Distributed leadership is about ensuring effective schools in South Africa*. Rosenholtz (1989) explains that generally there are two types of schools in South Africa: schools that are stuck and schools that are moved through teamwork. Stuck schools are schools with lower levels of learner achievement where the educators work on their own (seldom asking for help) and there is little to no evidence of leadership. At a moving school, there is evidence that educators work more collaboratively. This includes the principal of the school who helps educators to achieve goals and consequently learner achievement improves. Moving schools do not necessarily have all the equipment and resources, but with a teaching force that works together to solve problems, many obstacles can be overcome. Moving schools have principals who lead, as well as educators who also lead in terms of their classrooms or departments. There is a collaborative approach to leading evident in all parts of the school.

SAMPLE A – Quotes from in-depth interviews

P1 HOD: Too many, way too many see the profession just as a way of getting a salary. They do what is expected but they don't walk the extra mile. You will have to walk the extra mile if you want to make it successful. You will have to focus on what you have to do; your interest must be at school. I don't think everybody feels that way!
P2 DP: Other teachers, if they are loaded with leadership abilities, then yes, I can see that work but in South Africa I have grown up in the environment that you need management. Personally I don't think that it is going to work.
P3 HOD: Yes, because most of the schools in South Africa have a lot of the good leaders, but they are older leaders. They are leaders of fifty or sixty. There are also leaders in schools that are young leaders that have a different view on specific things. So, if you distribute the work, you will get a different input because time is changing, the curriculum and children are changing.
P4 CT: Definitely. Anybody of any position who is in a leadership position and has the right attitude and channels people properly can make a great success of any school, it's very important.
P5 SJL: In some schools and I am not supposed to say which schools, but let's say the old Model 'C' schools where the people have got the knowledge, they are actually brought up in a leadership way, they have got the responsibilities and everything, there it will work. But in eighty per cent of our schools I don't think it will work because a lot of the headmasters and teachers don't have discipline. I mean, we see it on television. Teachers coming late for classes. Not pitching for classes.
P6 P: If I think globally about the schools in South Africa the straight answer would be yes and no. For the simple reason that we are sitting with two worlds in the schools in South Africa. We have got independent schools, then we have got the ex-Model C schools which were the former white schools and then we have got the black schools. Without trying to sound racist or anything, if I look at the mere facts on the table the independent schools are way ahead for the simple reason that they have got all the resources, they have got all the support, they have got all the money, everything they need they have got. Because of the situation in the education system in South Africa, which is not what it should be quite a number of the good educators are being bought by the independent schools to resign from the government schools and to go and teach at the independent schools. So, you are busy losing high quality educators to the independent schools because the classes there are a lot smaller, there is less abuse from the learners in the private schools and the child can be expelled from a private school. While in the government schools, the ex-Model C schools where there is still a majority of white management and white educators, they have got a completely different approach to work ethics and that is perhaps the bottom line and the core word in this whole answer, is work ethics. Those teachers have got work ethics, they won't strike, they won't stay away for no reason, they won't have other interests like taxi businesses, shebeens and funeral parlours and things like that. Their priority one, two and three is education and they want to do the best for their learners and they coach sporting activities after school free of charge and they do cultural activities after school free of charge. Then you get your so-called black schools. There the distribution of powers will not work, for the simple reason that in their culture they only do what is in their job description and if their job description is not to be in charge of a certain thing, they will not take the responsibility for it. They don't even take responsibility for what is in their job description, let alone for what is outside their job description. The biggest problem in their schools is punctuality, the biggest problem there is attendance, they don't attend school. If they do attend school the other problem is that they don't attend school for the duration of the day, half way through the day they just excuse themselves. The principals there come late for school and leave early. They are the last ones to arrive and the first ones to leave while it should be the other way around. The principals there [and I know a number of them personally] have got funeral parlours, they have got shebeens; they have got taxi businesses so their priority is not the school and they will never buy ownership of the school. In my instance where we had an official strike last year, some of my parents are educators at their schools but their own children are learners in my school and then they will send their kids to school but they will come and toyi-toyi outside my school and be on strike! Now try and bring those two together. That's why I say 'yes' in two types of school distributive leadership will work but in the other type of school unfortunately I am sorry to say it's not going to work there for various reasons, for obvious reasons we see it on a daily basis.

Table 5.13 suggests that the leaders are divided about the role of distributed leadership to ensure effective schools in South Africa. Some of the respondents referred to dysfunctional schools and the reasons why they thought that distributed leadership would not be effective at dysfunctional schools.

Table 5.13: The effectiveness of distributed leadership at South African schools

Job role	For	Against	Uncertain	Effectiveness of distributed leadership at SA schools
Middle Leader		X		Only about salaries and not about extra effort to improve the school.
Management		X		Management at rural schools not capable.
Middle leader	X			Younger and new teachers also capable to lead.
Class leader	X			Positive attitude from leaders to lead.
Middle leader			X	For: Model C school leaders capable Against: Management at rural schools have no discipline.
Management			X	For: Functional schools have good recourses and good teachers with good work ethics. Against: dysfunctional schools will not take responsibility to developed. Punctuality and attendance of teachers a problems. Principals have second businesses (taxis or shebeens) and their schools are not priority one. Principals also strike and toyi-toyi in front of functional schools.
Total	2	2	2	

Pie chart 7 clearly illustrates the division amongst leaders about the effectiveness of distributed leadership to ensure effective schools in South Africa.

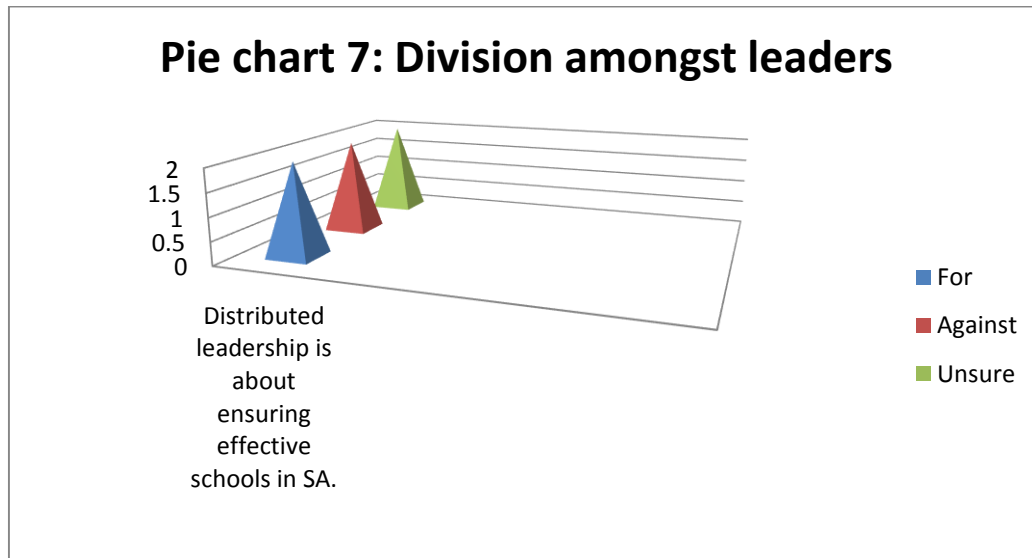

The role of distributed leadership to ensure effective schools in South Africa can be summarised in table 5.14. The researcher also included reasons why leaders are under the impression that the distribution of leadership will not be effective at some South African schools. The findings regarding the acceptance and areas of concern of the distributed leadership model will be discussed in chapter 6,

Table 5.14: The role of distributed leadership to ensure effective schools in South Africa

Acceptance of distributed leadership as leadership strategy to ensure effective schools	Areas of concerns
<p>Capable younger teachers can also lead.</p> <p>Enthusiasm from leaders to lead from the front.</p> <p>Model C schools' managements are capable to lead from the front.</p> <p>Functional schools are resourced effectively.</p> <p>Positive work ethics from teachers.</p>	<p>Lack of commitment to improve the educational systems. Principals have second business to generate more income.</p> <p>No passion for the learner, all about money. No sense of taking responsibility to improve the education system within the school.</p> <p>Lack of discipline from management at dysfunctional schools.</p> <p>Management toyi-toyis and strike in front of functional schools.</p>

SAMPLE B – Quotes from in-depth interviews

P7P: I believe it is possible. The only major challenge is leadership development of the person that must head leadership distribution. If I can say, principal development, because unfortunately in our system principals are people that go through the ranks. They do not have management leadership development, etc., so an educator that has to go the experience route; a certain number of years post level 1, certain number of years post levels 2 and 3 and through experience they learn certain management abilities and functions. Whereas if there is a part or a section that focuses on principals training, principals management because every organisation must have a leader, where the person can be entrusted then to distribute leadership. He must be a leader to be able to distribute leadership. In a functioning school absolutely. If there is a common goal, a common vision, everyone knows where they are going to, everybody knows what the end result is going to be, and distributive leadership can absolutely.
P8SJL: Yes, that can work if you can do it in clusters with a cluster leader and your cluster leader is capable of doing it then surely it can work.
P9 GL: Definitely it will. As long as the headmaster at all the schools is really good leaders. It is also only a good leader who will be able to distribute these tasks successfully. If that headmaster is not a good leader he won't take control at the end of the day. He won't monitor it. He will leave it and then it will go for nothing. He must be the final control still. The headmaster must be a good leader.
P10 DP: Yes I definitely think so. I think that there are a lot of schools, especially in our rural areas that don't do that. The simple reason at a lot of these schools is that the teachers are so scared of the principal that they dare not ask him anything and the principal I don't think trusts these people in order to delegate anything to them. So, he keeps it all to himself.
P11 and 12 CT and TA: CT: Yes, I think so because I think that is the problem with some of our schools that are far from cities. I think that the experience from the teachers and the leaders is not always there to help the younger teachers when there are problems. Yes, I think it will definitely help. TA: Yes, I agree. I also think so, because more leadership won't cost a thing.

All leaders agree that distributed leadership as leadership strategy can ensure more schools that are effective in South Africa. Table 5.15 describes the effectiveness of distributed leadership within South African schools.

Table 5.15: The effectiveness of distributed leadership at South African schools

Job role	For	Against	Uncertain	Effectiveness of distributed leadership at SA schools
Management	X			Principals are trained and equipped to do the job.
Middle leader	X			Cluster leaders at functional schools can support dysfunctional schools.
Middle leader	X			Principals are effective and have good leadership skills.
Management	X			Most principals have an open door policy and staff is not scared of the principal.
Class leader	X			Younger teachers are supported by management.
Class leader	X			More leadership without extra cost.
Total	6	0	0	

Pie chart 8 illustrates that all the leaders agreed that distributed leadership could have a positive effect on schools in South Africa.

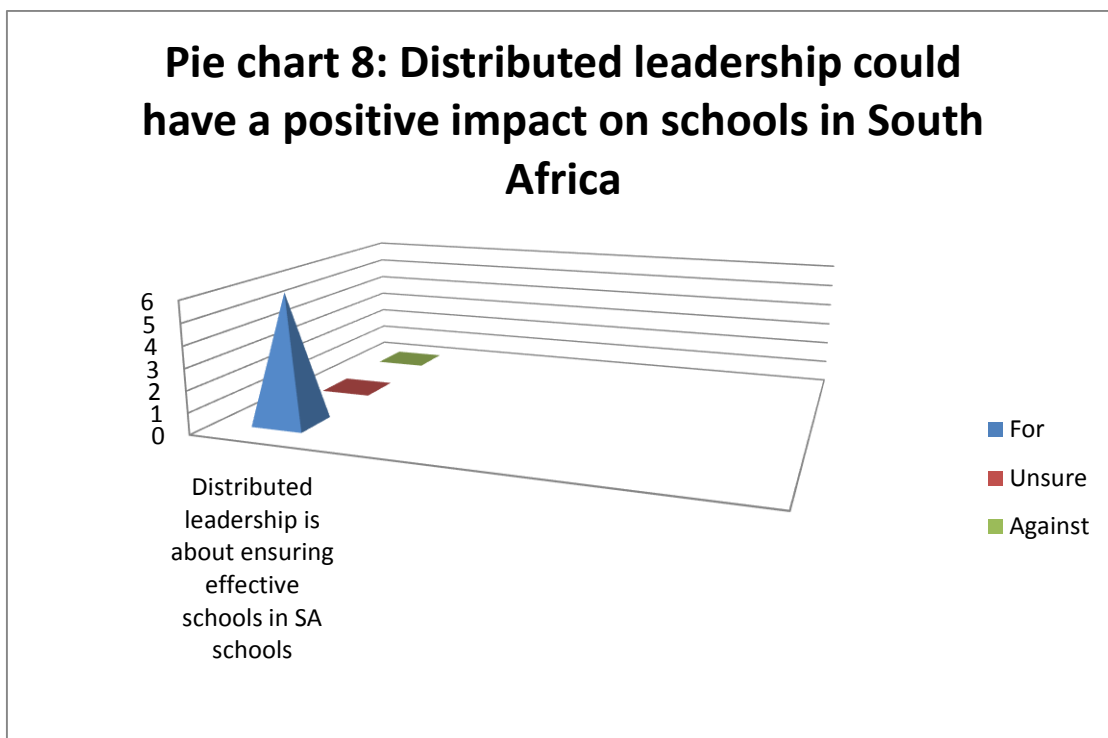

Table 5.16 will explain reasons why leaders are in the opinion that distributed leadership is about ensuring effective schools in South Africa.

Table 5.16: The effectiveness of distributed leadership at South African schools

Acceptance of distributed leadership as leadership strategy to ensure effective schools	Areas of concern
<ul style="list-style-type: none"> • Principals are trained and effective to do the job effectively. • Cluster leaders at functional schools can support dysfunctional schools. • Younger teachers are supported to be leaders. • No extra financial cost to distribute leadership in schools. 	<ul style="list-style-type: none"> • None

SAMPLE C – Quotes from in-depth interviews

P13 DP: Yes, I think so because teachers are getting older and the younger ones must develop so that they can take the place of the older ones in future. The whole world is developing, so the same thing happens at school.
P14 HOD: Definitely.
P15/16 CT and TA: CT: I think it could do because then, for example, I can take a leadership role in something specific. TA: I think so, because then it gives the teachers the opportunity to take a leading role at the school.
P17 SSL: If we distribute leadership, I think the chances to enhance our school will definitely be there, because you give other people a chance to learn. You also give other people a chance to develop themselves and it is of more use that you will get from different sides. Different people will have different views.
P18 P: Absolutely, yes, it can. We give our post level 1 teachers the opportunity to sit in management and every three months we change one of them to give somebody else a chance so that they can see what happens at management level and so that they can go out and have a much better idea of how things work in a school. So, I think by doing that we develop the people and give them insight in this type of distributive action that is taking place.

Table 5.17 and pie chart 9 indicates that all leaders agree that the distribution of leadership can ensure effective schools in South Africa.

Table 5.17: The effectiveness if distributed leadership at South African schools

	For	Against	Uncertain	Effectiveness of distributed leadership at SA schools
Management	X			To develop as leaders, especially new or younger teachers.
Middle leader	X			To develop as leaders, especially new or younger teachers.
Middle leader	X			To develop as leaders, especially new or younger teachers.
Management	X			To develop as leaders, especially new or younger teachers.
Class leader	X			Opportunities for post level 1 teacher to be in a management roles.
Class leader	X			Teachers also have an opportunity to take a leading role at the school.
Total	6	0	0	

Pie chart 9: Distributed leadership is about ensuring effective schools in South Africa

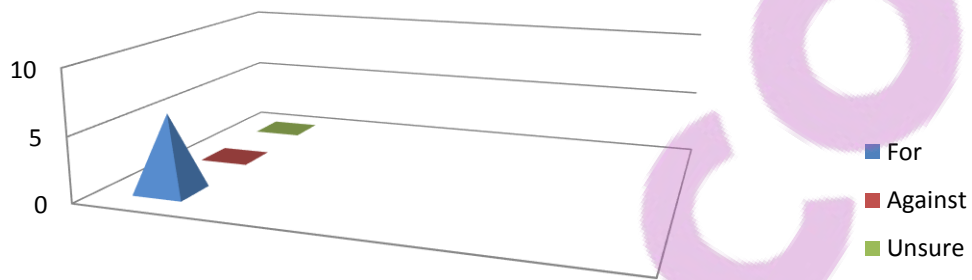

The effectiveness of distributed leadership strategies at South African schools are summarised in Table 5.18.

Table 5.18: The effectiveness of distributed leadership strategies at South African schools

The effectiveness of distributed leadership strategies at South African Schools	
Acceptance of distributed leadership as leadership strategy to ensure effective schools	Areas of concern
<ul style="list-style-type: none"> • Post level 1 teachers can also be leaders at the school. • Opportunities for new or young teachers in the profession to develop as leaders. 	<ul style="list-style-type: none"> • None

SAMPLE D - Quotes from in-depth interviews

P19 HOD: Yes. Right now we are at a point where we feel that more leadership should be given to staff because we are almost too narrow in leadership. So let me explain that, you have got your principal and your four HODs. You have got your senior primary high school HOD administrative HOD who is also a teacher. And that is it. But you have got senior teachers, for example, who although they might not want to be an HOD, they might want more responsibility. They want to be able to show you their leadership skills. We are at a stage where we would like to encourage those teachers to take on more and we would like to have grade heads, subject heads. This is the first year where we have gone and adopted a mentoring system for each grade. Normally all of that would fall under my phase. I would do everything for Grade 4 to 7, but now I have mentors in Grade 4, Grade 5, Grade 6 and Grade 7 and I can say minor problems will go to the mentors and major problems will be sent to me as the Head of Department. And this is a form of leadership and encouragement to staff to become better leaders. I am still in my forties and I am still young enough to be a leader, but a lot of our staff is in their early and late fifties. You <i>have</i> to prepare your younger staff for leadership, because nobody is indispensable and only by preparing them will they be good leaders. It is like you said earlier, you learn through experience.
P20 HOD: Definitely. It will provide an effective running of the school because certain areas won't be neglected. When you just have one leader, then areas will fall short because that leader is not going to get to do everything. When you have distributive leadership a lot of expertise will get through to it.
P21 CA: Yes, definitely, because I think you take ownership and when you have different people you take ownership of your school.
P22 CT: Definitely, yes. You know, if I wake up in the morning and go to work and I know that I have responsibility A to C and my colleagues come to work with the responsibility D to whatever and we all do our parts and we all work from different angles. In that case we can reach our goal at once to better every team and everybody on board rather than that someone is doing that and I am just a teacher. You know having that responsibility you also begin to love your environment and love your school. I know that if I have another responsibility on the school premises I do that other than just teaching, I am part of the school. So, yes, definitely.
P23 P: I do, sometimes I think that we assume that the teachers have too much on their plates and I am at fault with that and I think I would rather do it myself because I know they are very busy. I think if distributive leadership is taken to its fullest you are going to ask for a little bit more from everybody but they are going to benefit from it, because they also are more involved with the leadership of the school. So, I would say if I had to look at myself I could delegate more to other people and it would benefit the school. We are starting to do it more now but we can do even more.
P24 CT: It can, but I still think that you need to have somebody at the top for guidance, there needs to be somebody. We cannot all just be going in different directions. But that sounds like if there is nobody at the top that that is what could happen. We need someone just to hold it all together.

All the respondents agreed that the distribution of leadership can ensure more schools in South Africa that are effective. Table 5.19 and pie chart 10 clarify the reasons why the leaders are in consensus.

Table 5.19: The effectiveness of distributed leadership at South African schools

Job role	For	Against	Uncertain	Effectiveness of distributed leadership at SA schools
Middle leader	X			Lead as leaders and encourage staff to become better leaders.
Middle leader	X			Manage school effectively and certain areas would not be neglected.
Class leader	X			Take ownership within school.
Class leader	X			Lead their teams effectively within the school.
Management	X			More teachers involved with leadership within the school.
Class leader	X			Manage and support teams from the top.
Total	6	0	0	

Pie chart 10: Distributed leadership is about ensuring effective schools in South Africa



It emerged from the respondents that staff must be motivated in their teams to be effective leaders. Table 5.20 will give a clear indication the role of distributed leadership to ensure effective schools in South Africa.

Table 5.20: The role of distributed leadership to ensure effective schools in South Africa

Acceptance of distributed leadership as leadership strategy to ensure effective schools	Areas of concern
<ul style="list-style-type: none"> • Motivation of leaders to be better leaders in their teams. • More teachers involved with leadership tasks to improve the effectiveness of the school. • Management has support programmes in place to support teams effectively. 	<ul style="list-style-type: none"> • None

SAMPLE E – Quotes from in-depth interviews

P25 P: Yes, if the attitudes of all the teachers in the country is going to be a passionate one towards education. I think the major problem at this stage is that 80% of the educators in this country are just there to get their pay at the end of the month and are not prepared to work. We have got a case now at the moment with one of our best schools in our township area that has never had a failure in matric. 100% pass rate every year and this year the teachers have now decided that they no longer want to make use of this principal who has been the principal ever since the start of the school. They have now decided that they will not go to school because they no longer want to take his instructions to work and that is a problem in our country. If you have a staff like ours we are going to have a successful country, because they are all prepared to be on board and to do their fair share and work themselves to death.
P26 HOD: I don't know, because it is difficult, you have got two completely different people here and I am telling you now that this will work like a dream at many South African schools but I don't think it will work all over.
P27 CT: I think it will work because when leadership is distributed they don't take the duties of the principal as solely his or her own responsibility at that school, because people will just be careless at school and know that there is somebody who is responsible for this so, 'why should I do this?' But, if they had distributive leadership, then everything is shared amongst the personnel at school, so it becomes easy for everyone and everyone knows that he or she is accountable for the work that is done at school.
P28 CT: No. Tell me why. Unfortunately some of the rural schools, I don't think they have so much passion. You hardly have a teacher that pitches for her class.

The leaders in this sample were not sure if distributed leadership could improve South African schools. Half the leaders were for the distribution of leadership to ensure effective schools in South Africa. Table 5.21 will give a clarification of the different views of the effectiveness of distributed leadership at South African schools.

Table 5.21: Leaders are not sure if distributed leadership will contribute to the effectiveness of schools in South Africa

Job role	For	Against	Uncertain	More opportunities for leaders to
Management	X			Share leadership across the school.
Middle leader			X	Not sure about dysfunctional schools.
Class leader	X			Share leadership and accountability across the school.
Class leader		X		No passion in dysfunctional schools.
Total	2	1	1	

Pie chart 11 also indicates that leaders do not agree whether the distribution of leadership will ensure effective schools in South Africa

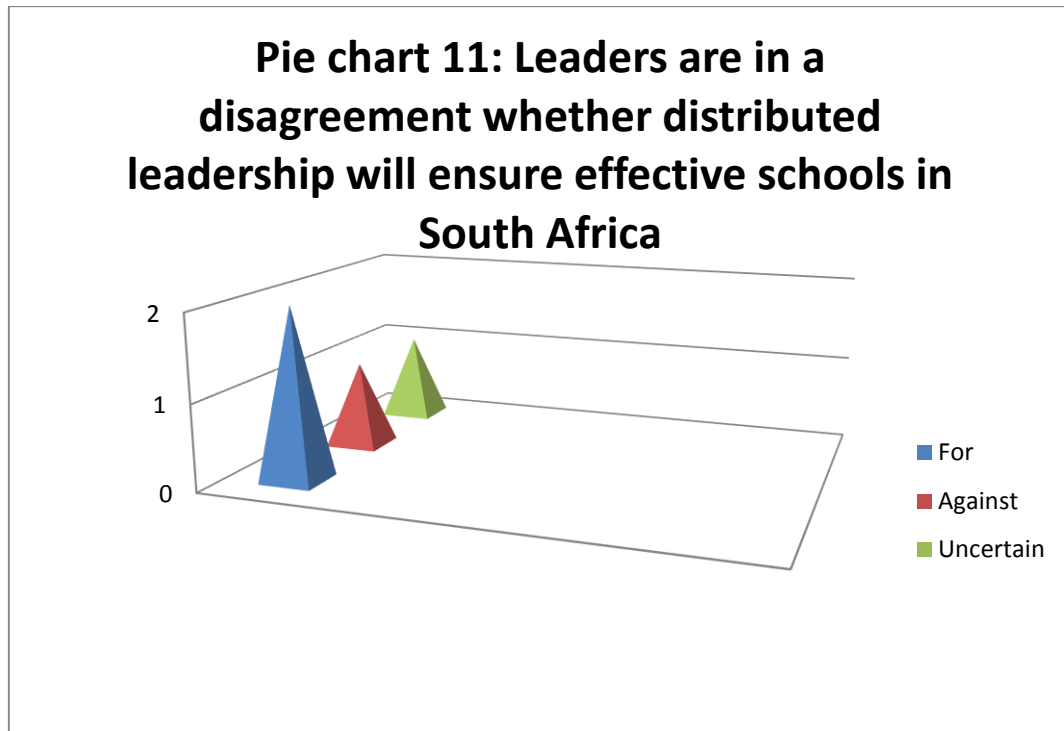

Pie chart 11 revealed the uncertainty of leaders concerning the effectiveness of distributed leadership within South African schools. Table 5.22 will give a clearly picture of the reasons why some leaders are uncertain about the effectiveness of distributed leadership within South African schools.

Table 5.22: Uncertainty with some leaders

Acceptance of distributed leadership as leadership strategy to ensure effective schools.	Areas of concerns.
Sharing of leadership.	Not sure about dysfunctional schools. No passion for teaching at dysfunctional schools.

Table 5.23a and 5.23b explain the overall acceptance of leaders that the distribution of leadership could have a positive impact on the effectiveness of the distribution of leadership within South African schools. However, the tables also indicate the areas that need further development to ensure total effectiveness.

Table 5.23a: The acceptance of distributed leadership as a leadership strategy at South schools

The acceptance of distributed leadership as a leadership strategy at South African schools			
Sample	For	Against	Uncertain
A	2	2	2
B	6	0	0
C	6	0	0
D	6	0	0
E	2	1	1
Total	24	2	2

The researcher decided to code against and uncertain in to a new code and classified this code as against. Table 5.23b will give a clear picture of the acceptance of distributed leadership as a leadership strategy at South African schools.

Table 5.23b: The acceptance of distributed leadership as a leadership strategy at South African schools

The acceptance of distributed leadership as a leadership strategy at South African schools		
Sample	For	Against
A-E	24	4
Total	24	4

Pie chart 12 illustrates the effectiveness of the distribution of leadership at South African schools.

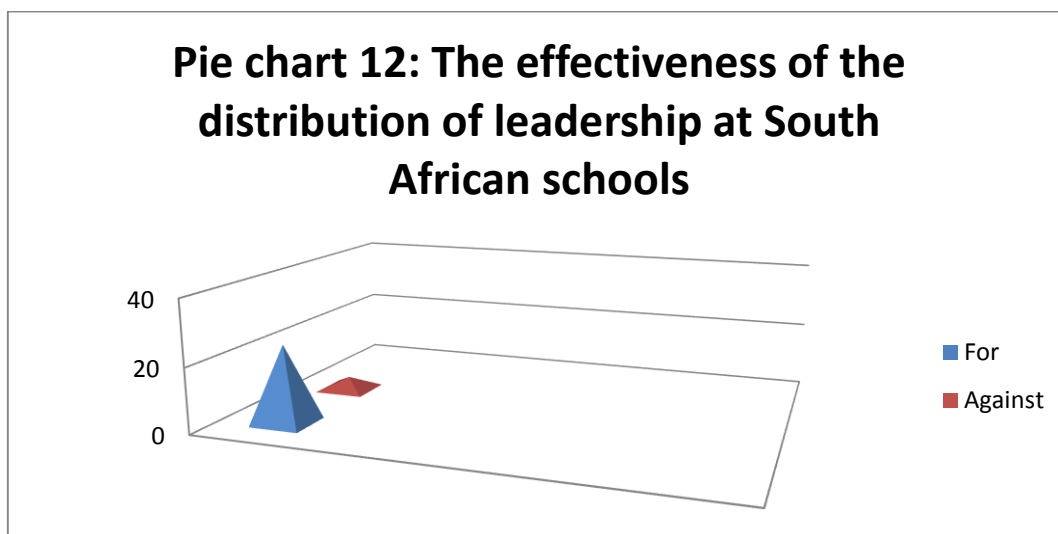

Table 5.24: Elaborates on the acceptance of the distribution of leadership at South African schools

Acceptance of distributed leadership as leadership strategy to ensure effective schools	Areas of concern
<ul style="list-style-type: none"> • Management are capable to lead from the front and have support programmes in place to support teams. • Cluster leaders at functional schools support dysfunctional schools, • Post level 1 and new teachers are supported to be leaders at the school. • No extra financial cost to support the distribution of leadership within schools. 	<ul style="list-style-type: none"> • Lack of commitment to improve the educational systems. Principals have second businesses to generate more personal income. • No passion for the learner, all about money. No sense of taking responsibility to improve the education system within the school. • Lack of discipline from management at dysfunctional schools. • Management toyi-toyi and strike in front of functional schools.

The next theme under discussion is about the development of coaches as a distributed leadership strategy.

5.4.7 Theme 7: Distributed leadership is about the development of coaches as a distributed leadership strategy

The researcher wants to discover through this theme whether leaders were trained to be coaches at schools. Hoskings (1988; 1991) states that building on the theme of leadership as a social process, is a notion of distributed leadership that emphasises leadership processes and skills, as well as orientation that encapsulates a perspective beyond formal roles of designated leader. The researcher wants to assume that the development is occurring when developmental training takes places.

Sample A – Quotes from in-depth interviews

P1 HOD: No evidence of coaching as leadership strategy.
P2 DP: No evidence of coaching as leadership strategy.
P3 HOD: No evidence of coaching as leadership strategy.
P4 CT: No evidence of coaching as leadership strategy.
P5 SJL: No evidence of coaching as leadership strategy.
P6 P: No evidence of coaching as leadership strategy.

SAMPLE B– Quotes from in-depth interviews

P7P: No, I haven't had any training in mentoring, coaching or anything like that.
P8SJL: Did you ever have the opportunity yourself to have training in the so-called how to run a coaching session? Yes. Many years ago when I was an Afrikaans subject teacher I had that opportunity and it was wonderful.
P9 GL: No, I have never had something like that.
P10 DP: No.
P11 and 12 CT and TA: CT: I don't think it was a formal, proper training session. TA: No, training

Sample C – Quotes from in-depth interviews

P13 DP: Myself, no.
P14 HOD: Many years ago. Probably about 10 years ago in our 'ward', they presented Head of Department and Deputy Principal workshops.
P15/16 CT and TA: CT: No. TA: No.
P17 SSL: No, I have had no formal training.
P18 P: No.

Sample D – Quotes from in-depth interviews

P19 HOD: No.
P20 HOD: No.
P21 CA: No.
P22 CT: Definitely no.
P23 P: No.
P24CT: Never.

Sample E – Quotes from in-depth interviews

P25 P: Never.
P26 HOD: I have not had formal training except my master's degree, I would say.
P27 CT: Yes, I had.
P28 CT: Yes, we had some training. I wouldn't say intense, but we had some training.

Table 5.25 clarifies that leaders in South Africa need to have training to become coaches to develop the teaching profession in South Africa.

Table 5.25: Formal training as a coach

Sample	Yes	No
A	0	6
B	1	5
C	1	5
D	0	6
E	2	4
Total	4	24

Most of the respondents acknowledged that they had no training to become coaches at schools. Table 5.25 can be illustrated as follows in pie chart 13.

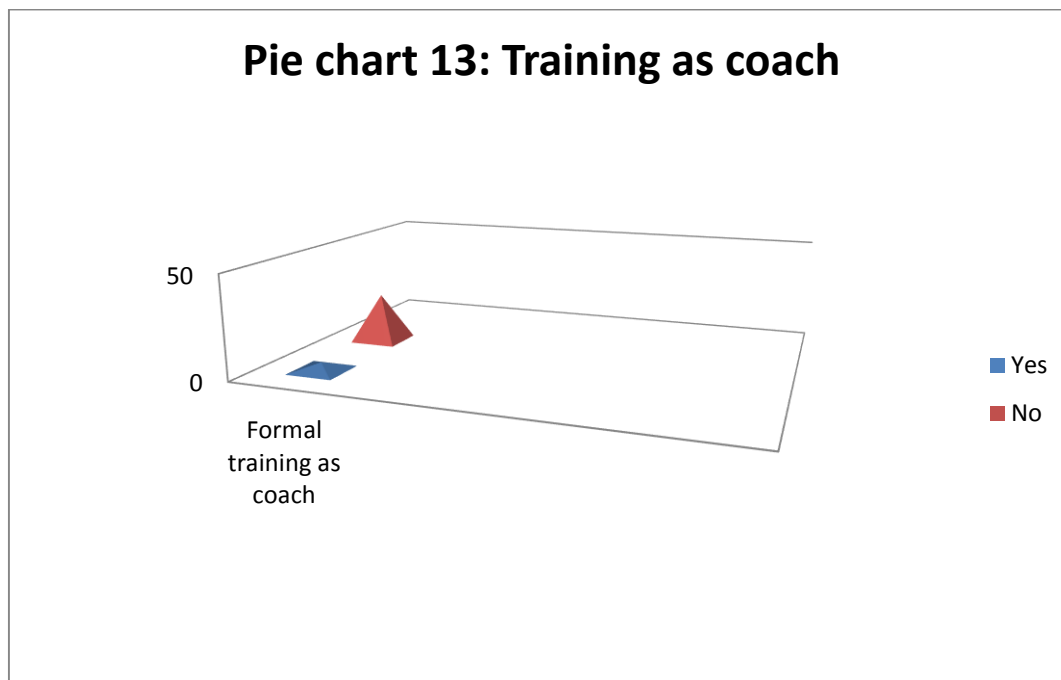

The data in pie chart 13 reveal that leaders at South African schools are in need of getting training to become coaches within the education department. The researcher decided to implement the OSCAR coaching model as distributed leadership strategy to ensure effective schools. The next theme that will be discussed is: *Distributed leadership is about the OSCAR coaching model to facilitate meetings as distributed leadership strategy to ensure effective schools.*

5.4.8 Theme 8: Distributed leadership is about the OSCAR coaching model to facilitate meetings as distributed leadership strategy to ensure effective schools

The biggest problem with meetings is the fact that most meetings have no planned structure. OSCAR is a simple process for structuring a meeting agenda. Leaders spend a large proportion of their daily work life in meetings. Many meetings are badly run and time-consuming. It is important that leaders need to make the most of their meetings. The previous theme proved that leaders are in need of training to become coaches.

The researcher decided to implement the OSCAR coaching model to facilitate meetings as a leadership strategy to ensure more schools in South Africa that are effective. Gilbert and Whittleworth (2009) explain that the benefits of well-managed meetings will:

- save time;
- improve motivation;
- create opportunities for better decision-making;
- resolve problems quicker;
- build stronger and more productive working relationships;
- establish meetings that involve the entire team;
- encourage participation and responsibility of all team members;
- ensure that there are less meetings where the leader tells; and
- instructs and make all the decisions.

Gilbert and Whittleworth (2009) add that any meeting, which involves discussion, problem solving and action planning, creates an opportunity for group coaching. According to these researchers, group coaching involves leadership without taking the reins, focusing on asking questions instead of telling and listening and building consensus.

SAMPLE A- Quotes from in- depth interviews

P1 HOD: Well, I organise all, for example, choir festivals, we have choir festivals, we have bell choirs and percussion bands and then you get cultural evenings where parents are invited to come and listen to them.

P2 DP: We meet once a week. At least once a week where we discuss the management of the school, the running of the school, and there we make decisions amongst ourselves.

P3 HOD: Everybody must have an input, I am not in control. We will have meetings, we will discuss it, everybody will go back think about it, come back and if there is a decision to be made I will do that but everybody needs to have an input.

P4 CT: Well, I think me being a teacher experienced for thirty years, I don't know everything, but I think I have acquired a lot of knowledge, so, for me to go most probably to someone at the school, I would go to someone who has taught a little longer than I have taught.

P5 SJL: I know that we have got a lady here teaching computers. She actually volunteered and asked me, but it is a little bit difficult because of the hours because we have got extra-murals.

P6 P: Yes, for teachers to work together it's a very good thing, that is why we have regular grade meetings, regular subject meetings, so that they are all aware of what is expected from them and that they are all at the same level by the end of the week and the same amount of work has been done by the end of the week.

All the respondents revealed that there are meetings at the schools. There is a range of meetings such as:

- Extra-murals (choir festivals)
- Management meetings
- Departmental meetings
- One to one meetings
- Meetings to discuss own development
- Grade meetings
- Regular subject meetings

It emerged again from the respondents that they needed to meet to discuss the development and the management of the school in the different phases.

There is a range of meetings at schools. The Oscar coaching model as distributed leadership strategy can be implemented at schools in South Africa to facilitate effective meetings. There are five strategies to ensure an effective meeting. The first strategy in the OSCAR coaching model is to determine the outcome of the meeting. Gibert and Whittleworth (2009:40) explain that managers have to plan for success. This involves thinking about what success would look like. This is sometimes referred to as vision. Managers with well-formed outcomes achieve much more than managers who do not have clear outcomes. The researcher will discuss the implementation, monitoring and evaluation of this strategy in more detail in chapter 6 (findings and recommendations).

SAMPLE B – Quotes from in-depth interviews

P7P: As I said, distribution of management functions. For example, if there are clubs and societies every educator has to be part of a club or society where they are responsible for the organisation and the logistics in the club. Every educator is also expected to be part of a winter and summer sports team, whether being in an administrative or in a coaching point of view, but their involvement there is also required. Other leadership opportunities when I encourage my staff and I know they are taking it up are when there are workshops being presented by the district office in specifically curriculum matters. I encourage them, because I know they are all fairly good and up to date with their academic arena of the learning area where they are teaching that they become part of that group at a district level. Being the right-hand person to the subject advisor, being aware of all the policies and the protocols with specific regard to their academic function at school. So, I am trying to get them and I know they will all endeavour themselves to get into places where they contribute on a bigger scale than just the school. We are talking about subject committees in the district, examination committees, etc. so, a relatively major portion of my staff is involved in committees like that.

P8SJL: I also have to have minutes of meetings that we have.

P9 GL: Well, there I have to make sure that the curriculum is in place. That all the notes they need are there, all the work that they have to do is prepared. Well, there I have to make sure that the curriculum is in place. That all the notes they need are there, all the work that they have to do is prepared.

P10 DP: For instance, I was Head of Sport as well and it is too much to handle for one person, so I have given that (the whole Sport portfolio) to one of the other teachers who is also the Physical Education teacher, so it fits into his role a little better. I still do a lot of the admin work, but he does the rest.

P11 and 12 CT and TA: CT: Well, now and then we have subject meetings and we have got our subject head. At this stage it is Mr X. But years back we had a math subject group in town so I have learnt a lot from those people. Once in six months they got together and certain teachers had the chance to give a class to all the teachers in a certain part of the math. I learnt a lot through that and that was coordinated by our subject advisor from the Department. He was Mr Y from Pietermaritzburg. That helped us a lot. In the meantime, I can go to Mr X if I have a problem or even go and talk to teachers at other schools that are also teaching the subject. We have a subject advisor at this stage also from our District Office, but I don't think it is working at this stage.

It is clear from the respondents that the school meets for different type of activities to ensure effective management of the school. The Oscar coaching model as distributed leadership strategy can be implemented as a leadership strategy to ensure more schools in South Africa that are effective. The second strategy regarding the Oscar coaching model is about the situation. The situation is the reason why leaders at all levels have to meet. In each of these meetings that will be a different situation.

These situations include matters such as:

- responsibility to organise all the logistics in the different clubs of the school;
- subject meetings in district to discuss subject matters at schools;
- examination committees to discuss examination;
- ensure that curriculum is well organised and developed;
- meetings with head of sport; and
- discussion and solving of problems within maths.

Gilbert and Whitleworth (2009:41-42) are of the opinion that managers need a grip on the situation. They need to know what is going on in their team. They need to know what is happening in the organisation. They need to know the facts. Managers are faced with difficult situations on a daily basis. The greater the clarity they have on the situation, the quicker they can overcome the hurdles and obstacles that stop them achieving their outcomes. To understand the situation in their team in full, they will have to listen to the team members and understand the situation from the perspective of the individual team members. The implementation, monitoring and evaluation of the Oscar coaching model to facilitate meetings will be explained in more detail in chapter 6 (findings and recommendations).

SAMPLE C – Quotes from in-depth interviews

P13 DP: I always have meetings with all the subject leaders at the beginning of the year. There is a policy document that I developed for them and they come to me if there are any problems during the year.
P14 HOD: Once a month I hold an Afrikaans meeting. Once a term we have our senior phase meeting. People will come and ask you questions during break times, e.g. "I have a problem with this, can you help me?" This is where your leadership comes in. It doesn't just have to be a structured thing that is discussed during a formal meeting.
P15/16 CT and TA: CT: Yes, like the sports and culture people, I have been asked to join their committee and there I can share my ideas and that sort of thing.
P17 SSL: We normally have it quite at the beginning of the year and we have it once a term with our general teachers meeting there will be certain questions and things that will be discussed. But on a weekly basis or a monthly basis at this stage we don't.
P18 P: We have a system of adopting a school. Schools in the rural areas that are not on the same level as ours. And by us setting the example and by us showing the way things are done in meetings and in courses and the inputs we have.

Every meeting that is conducted at the school have a specific cause (reason why you need the meeting) with a consequence (outcome of the meetings) after the meeting. It emerged from the responses that there was a need for meetings to discuss different structures within the school. The third strategy about the Oscar coaching model is all about causes and consequences.

Meetings identified are:

- Quarterly/Annual team meetings to discuss policy documents
- Subject meetings
- Senior phase meetings
- One-on-one meetings
- Sport committees
- Class-teacher meetings to discuss curriculum every term
- Meetings will cluster schools

Gilbert and Whitleworth (2009:41-42) are of the opinion that managers need a grip on the situation. They need to know what is going on in their team. They need to know what is happening in the organisation. They need to know the facts. Managers come face to face with difficult situations on a daily basis. The greater the clarity they have on the situation, the quicker they can see around the hurdles and obstacles that prevent them from achieving their outcomes. To understand the situation in their team in full, they will have to listen to the team members and understand the situation from the perspective of the individual team members. In chapter 6, a detailed discussion will be given on the Oscar coaching model and the impact of the model on whole-school development.

SAMPLE D – Quotes from in-depth interviews

P19 HOD: We hold regular meetings where we discuss issues. I also think that we try and socialise a little bit together. It is not a lot, but we try to get time to do that. We actually form a community through sport and another thing that I do as the Senior Primary HOD actually twice a year we have what we call our creative weeks where we all get together and we brainstorm for that week after the exams. Often after the exams the children are bored and they don't come to school. So, we have made it in our school almost like a thing you have got to come to school in that week because that is the week where we will do fun things.
P20 HOD: Normally what he has basically done here at our school is that there are the HODs for their phases and if there is a problem we have a meeting with him where we discuss it and take it from there.
P21 CA: Yes, she will say, "Can you please do this for me in the next lesson?" Or "Will you be able to help me here?" She won't sit, for example, on a Monday and say, "This and this is going to happen." It's more spontaneous. We have got our sequence that we do for the day and the week and we work through that unless there is a change in something and she needs to go to a meeting, then I will fill in for her.
P22 CT: We have a programme where now and then we get the HOD and discuss about our work and things like that and there is a lot of empowerment through that. My principal is also a friendly and open person. You can go to his office at any time, so there are opportunities where we meet and discuss things now and then, but even if it is not a problem, but just speaking or telling you, you are here what your concerns are. You know, there is a trend we have at our school.
P23 P: Let's just take an example, like now, we have introduced a pastoral care system or a mentor system where each of the heads of departments have mentors within their phase. They will have regular meetings with their mentors to find out whether they are carrying out instructions of what is expected of a mentor. So, they will have meetings and I won't necessarily meet with everybody but they will feedback to me on a weekly basis. I have weekly one-on-one meetings with my heads of department where they will give feedback on their tasks that they have given to their distributive leadership, whoever they have got in charge of something. I won't sit in on all of them but I will just get the feedback.
P24 and P 25CT and CA: We follow through and we talk about problems with children, if there are problems with staff, problems with the preschool that is staff problems I had. He makes his notes and we will either call people in together or we make a decision about what we are going to do about different things then. This is how the mentor came up in the preschool, because I was just overloaded, so it was at one of these meetings I said, "Can somebody just be there?" He thought and it came up from his side too because I can't get there. I am teaching thirty Grade 1s and I cannot get up to preschool this year.

It is evident that many meetings take place at schools to discuss different issues. Meetings are conducted for different reasons. It emerged from the respondents that they had meetings to discuss issues, e.g.:

- Meetings to plan for creative weeks
- Meetings to plan for sport events
- Meetings to solve problems within phases
- Weekly meetings to plan weekly curriculum plans
- One-on-one meetings with principal to discuss personal matters

- Mentor meetings at school
- Meetings to discuss personal progress with HOD
- Meetings with parents to discuss problems with individual learner

The fourth strategy in the Oscar coaching model to facilitate meetings as distributed leadership strategy is about actions. Gilbert and Whittleworth (2009:43-44) explains that managers need to be action planners. The action plan coordinates the team's efforts on a daily basis. Team members need to know what is expected of them, what they are expected to do and when they are expected to do it. Successful teams are proactive and action is essential. Action has to follow a process of establishing a clear outcome, a clear situation and having made the best possible choice to achieve the outcome. Many managers are familiar with action planning. Some even use a popular system such as a Ghant Chart to display the action plan visually, with colours to denote progress (typically the traffic-light system of red, amber and green). OSCAR provides the common-sense structure that enables action planning to be specific, focused and prioritised towards achieving the desired results. A discussion will follow in chapter 6 (findings and recommendations) of how managers and leaders can take action effectively in meetings.

SAMPLE E – Quotes from in-depth interviews

P25 P: I enjoy doing what I call "brainstorming". We have just had one of those sessions again. I can give you an example of an old one we had. We are actually busy with it at the moment and I can pass it on to you. Here is one example and you can actually have that one. Just see if there is no writing on it. This is what I do and you will see that this is 2003. We started it as a policy in 2004. You will see we say there, 'collaborative effort by the whole staff after brainstorming effort'. I believe we have got experts within this school. All humans have their own specialties and I must make use of the experts within the school and I am now talking only about the staff. Obviously there are other stakeholders you can go to if you really don't have answers but most of the time I find the answers are within the school setup. If you look at the experts we deal with, I take it back to them, and I set up questions. What do I want to know? What do I want help with? T

P26 HOD: You know we have committees for everything! [Laughs]. At the beginning of the year we get these papers with all the different committees on and you will find that a lot of those committees are run by level 1 teachers and they are not run by management at all. You might think that some of them are silly but you have got the tuck shop which is run by two level 1 teachers and it is their responsibility. They take ownership of the committees. Then of course you have got your sport where you have an HOD that is in charge of sport and culture, but then you have a person that is in charge of the cricket. These are level 1 teachers that are actually

P27 CT: not refer once to meetings during interviews.

P28 CT: Well, firstly, we have a meeting every week where we first start by having a look to see where everybody is in the curriculum.

Once again, it emerged from the responses that meetings are important at the school. The Oscar coaching model to facilitate meetings as a distributed leadership strategy can be implemented as a leadership tool to ensure effective schools. Meetings are conducted for the following purposes:

- Meetings to brainstorm strategies at the school
- Meetings with leaders at the school
- Meetings with different committees
- Sport meetings
- Cultural meetings
- One-on-one meetings
- Curriculum meetings

The fifth and last strategy concerning the Oscar coaching model to facilitate meetings is to review the meeting at the end. Gilbert and Whittleworth (2009:44) elaborate that managers need to stop and notice what is going on. They need to review performance. Managers attend meetings and all meetings are reviewed. You meet to review progression and, if you are on track, to achieve your outcome; share what is happening right now; what the situation is; what decisions you have to make to achieve an outcome; your actions and the success of these actions; which correct actions to take; and to take actions to get on track again.

5.5 CONCLUSION

In this chapter, the research results were analysed, interpreted and synthesised. The results were also discussed and synthesised to put forward a framework for the OSCAR coaching model to facilitate meetings as a distributed leadership strategy to ensure effective schools in South Africa, coupled by the discussions and illustration of findings from the from the research methods employed. The literature study and the theoretical assessment, especially the theoretical models of Spillane and Diamond (2007), Spillane (2004), Spillane,

Halverson and Diamond (2001, 2004), Cope (2004) and Gilbert and Whittleworth (2009), were applied to practice, based on the role of distributed leadership to ensure effective schools in South Africa.

Eight themes were identified from the literature and the in-depth interviews, which gave possible solutions to the research sub-questions as identified in chapter. The eight themes identified were:

- Theme 1: Distributed leadership is about teacher leadership
- Theme 2: Distributed leadership is about team work
- Theme 3: Distributed leadership is about democracy and sharing of leadership at all levels
- Theme 4: Distributed leadership is about interaction between leaders at all levels.
- Theme 5: Distributed leadership is about sharing of leadership and not delegation of leadership
- Theme 6: Distributed leadership is about ensuring effective schools in South Africa
- Theme 7: Distributed leadership is about the development of coaches as a distributed leadership strategy
- Theme 8: Distributed leadership is about the OSCAR coaching model to facilitate meetings as distributed leadership strategy to ensure effective schools.

The above themes were discussed using the distributed leadership strategy and the OSCAR coaching model to facilitate meetings as distributed leadership strategy. The research shows that leadership should be managed through the distributed leadership strategy and that the implementation, monitoring and evaluation of the OSCAR coaching model as distributed leadership strategy would ensure more schools in South Africa that are effective.

The OSCAR coaching model to facilitate meetings as distributed leadership strategy should be viewed as a working document in action and also a distributed leadership approach that can be applied for leaders at all levels and the school concerned. In the next chapter, the conclusions and recommendations of this research will be discussed in detail, including suggestions for further research.

CHAPTER SIX SUMMARY, FINDINGS AND RECOMMENDATIONS

6.1 INTRODUCTION

Krause and Powell (2002), Mestry and Grobler (2002), and Sayed (2000) indicate that the South African leadership study base is very limited. Studies on the availability of training and development and the needs of school managers dominate the field. What these studies show is that most principals do not receive adequate specialist training, especially in financial leadership and instructional leadership. Many studies on the foregoing issues focus on policy rather than actual practice. Furthermore, authors such as Bush and Odura (2006, in Mestry and Prakash, 2007) state that little formal leadership or management training exists and principals are appointed because of their teaching record, rather than their leadership or managerial potential. Induction and support are usually limited and principals have to adopt a pragmatic approach. Principals involved in the day-to-day leadership of their schools need to take time to reflect on their personal growth as leaders and managers. Muller and Marais (2004) add that school effectiveness study seeks to identify and isolate the relative effects of different practices on learner attainment and on overall school effectiveness. These studies tend to identify four sets of features influencing school effectiveness: learner characteristics, management practices, school inputs and teaching processes. Schools can be more effective by creating models, which will empower leadership teams to make schools more powerful to meet organisational goals.

The primary goal of the study was to determine the views of leaders on the distribution leadership approach as a leadership strategy:

- To define effective school leadership, leadership strategies and distributive leadership;
- To explore how distributive leadership support change and improve effective schools;

- To investigate how coaching can be used as an effective and successful distributed leadership strategy;
- To explore ways in which one design, implement and maintain coaching as a distributed leadership strategy to ensure effective school leadership in South Africa; and
- To explain how a distributive leadership model can be conceptualised as leadership strategy to ensure effective schools in South Africa.

The findings and recommendations will be discussed in this chapter and a model will be introduced as to how coaching can be used as a strategy to ensure effective schools in South Africa.

6.2 SUMMARY OF RESEARCH

In chapter 1, the background to the problem was discussed and the study questions were developed in accordance with the study problem. The aims and the objectives of the study were stated and the study design and methodology were outlined. A breakdown of the six chapters of this study was given and certain key concepts such as distributed leadership, leadership strategies and effective schools have been clarified.

Chapter 2 gave a literature overview of theoretical framework of the theories and practices of distributed leadership as strategy to ensure effective schools. The chapter addressed the following two research questions:

- What are effective school leadership, leadership strategies and distributed leadership?
- How can distributed support change and improve effective schools?

The concept of school leadership and the theory of school leadership were discussed. The relationship between democratic, teacher, dispersed, collaborative, shared, delegated and distributed leadership was put into context. The chapter discussed the role of distributed leadership as a strategy to change leadership through coaching and mentoring to ensure effective schools.

The chapter also guided the researcher towards the achievement of the major study problem: What is the role of distributed leadership as strategy to ensure effective schools in South Africa?

Chapter 3 gave a literature overview of coaching as distributive leadership strategy ensuring schools that are more effective. The chapter addresses the research question: How can distributed leadership be used as a successful and effective leadership strategy? A discussion was given on the collaborative nature of coaching as a seven-stage pattern that links to the distributed leadership strategy. An explanation was given on the role of coaches within educational settings. Five coaching models that can assure that schools are more effectively managed were discussed. Each of the coaching models was linked to distributed leadership. Coaching models included the GROW coaching model, STRIDE coaching model, OSCAR coaching model, strategic executive coaching model and team coaching model. A further discussion followed on the role of coaches to distribute leadership by means of coaching to assure effective schools. The researcher also gives an indication that the OSCAR coaching will be implemented as model to assure schools in South Africa that are more effective. A discussion was also given on the influence of internal coaching to enhance the distribution of leadership within schools.

The chapter also guided the researcher towards the achievement of the major study problem: What is the role of distributed leadership as strategy to ensure effective schools in South Africa?

In chapter 4, the researcher achieved the objective: ***“to explore ways in which one design, implement and maintain coaching as a distributed leadership strategy to ensure effective school leadership in South Africa.”*** The researcher also answered the sub-question: ***How does one design, implement and maintain coaching as a distributive leadership strategy to ensure effective schools in South Africa?***

The rationale for choosing the qualitative research method was explained. The researcher also gave reasons why the explorative, descriptive and contextual research designs were used in this study. Explanations were given on the ethical measures used in the study. The strategies and measures to ensure trustworthiness were also explained in detail. Clear descriptions were given on the methods to collect and analyse data.

In chapter 5, the research results were analysed, interpreted and synthesised. The results were also discussed and synthesised to simultaneously put forward a framework for the OSCAR coaching model to facilitate meetings as a distributed leadership strategy to ensure effective schools in South Africa, coupled by the discussions and illustration of findings from the from the research methods employed. In chapter five the OSCAR coaching model to facilitate meetings were only introduced. The literature study and the theoretical assessment, especially the theoretical models of Spillane and Diamond (2007); Spillane (2004); Spillane, Halverson and Diamond (2001, 2004), Cope (2004), and Gilbert and Whittleworth (2009) were applied to practice, based on the role of distributed leadership to ensure effective schools in South Africa.

Eight themes were identified from the literature and the in-depth interviews, which gave possible solutions to the research sub-questions as identified in chapter one. The eight themes that were identified were:

- Theme 1: Distributed leadership is about teacher leadership
- Theme 2: Distributed leadership is about team work
- Theme 3: Distributed leadership is about democracy and sharing of leadership at all levels
- Theme 4: Distributed leadership is about interaction between leaders at all levels.
- Theme 5: Distributed leadership is about sharing of leadership and not delegation of leadership.

- Theme 6: Distributed leadership is about ensuring effective schools in South Africa.
- Theme 7: Distributed leadership is about the development of coaches as a distributed leadership strategy.
- Theme 8: Distributed leadership is about the OSCAR coaching model to facilitate meetings as distributed leadership strategy to ensure effective schools

The above themes were discussed using the distributed leadership strategy and the introduction of the OSCAR coaching model to facilitate meetings as a distributed leadership strategy. The research shows that leadership should be managed through the distributed leadership strategy and that the implementation, monitoring and evaluation of the OSCAR coaching model as distributed leadership strategy would ensure more schools in South Africa that are effective.

This summary highlighted some of the important aspects and procedures that were undertaken during this research. Important findings derived from the study will now be presented and recommendations made for school management and the leaders at all levels of their schools.

6.3 LIMITATIONS

- The fact that the study was conducted only in the Pumela Ward is a limitation on its own, because it is not representative of the rest of KwaZulu-Natal or the whole of South Africa.
- Dysfunctional schools refused to participate in the study. This indicates the effectiveness of rural schools in the province (See Appendix F). It came to the attention of the researcher that rural wants something in return before they will be willing to participate in developmental studies.

6.4 IMPORTANT FINDINGS ABOUT THE ROLE OF DISTRIBUTED LEADERSHIP TO ENSURE EFFECTIVE SCHOOLS IN SOUTH AFRICA

6.4.1 Findings with respect to teacher leadership

The researcher wanted to compare the viewpoints of different leaders to define effective school leadership at functional schools. The first aim of the study was to define effective school leaders. The researcher used the viewpoints of respondents. Overall, all leaders define leadership as the role of teachers as leaders to make schools more effective (par.2.5.3 and 3.4.5) Elmore (2000), York-Barr and Duke (2004) and Danielson (2007) give clear definitions in chapter two about teacher leadership. The researcher has determined that educational leadership is about teachers as leaders as discussed in the literature review in chapter 2. Teachers as leaders can be trained to become coaches, as explained by Cope (2007) and Gilbert (2009) in chapter 3. Most of the respondents agreed in the empirical study that educational leadership is about teachers as leaders. Teachers as leaders need to be in control of the situation when the Oscar coaching model to facilitate meetings to ensure effective schools are implemented (Gilbert, 2009). Both the literature review and the empirical study clearly indicated that educational leadership is about teachers as leaders who are in control of different situations within the school (par. 5.4.1)

6.4.2 Findings with respect to teamwork

In this comparative study, the researcher investigated the role of distributed leadership to ensure effective schools in South Africa between leaders in effective schools. The first aim of the study was also to define leadership strategies. The study revealed that leadership strategies are about teamwork. Teamwork is an important strategy to ensure the effective distribution of leadership within schools (par 2.5.3). There are six ways to distribute leadership to enforce teamwork within schools (NCSL, 2004), as discussed in chapter 2. Gilbert (2009) also clarified in chapter 3 that leaders need to be in control of situation when they implement the OSCAR coaching model to facilitate meetings

in order to ensure effective meetings (par 3.4.3). All meetings must have a clear purpose and the focus must be on the development of teaching and learning within the school. However, during the empirical study, the researcher determined that all the schools are in need of strategic distribution in order to ensure effective teamwork (par 5.4.2).

6.4.3 Findings with respect to democracy and sharing of leadership

The role of distributed leadership to ensure effective schools in South Africa was under investigation. This was a comparative study between leaders at effective and functional schools. The first sub-aim of the study also defined distributed leadership. In chapter 2 of the literature review, it was discovered that there is a clear link between distributed leadership and democratic leadership (par. 2.5.2). In addition, this study revealed that sharing of leadership tasks are an important element of distributed leadership (par 2.5.6). Important strategies of the OSCAR coaching model to facilitate meetings are choices, consequences and action (table 3.4.3). These strategies can have an influence on the development of the school. Every meeting must have a choice and a consequence. Group decision-making consists of brainstorming all the possible choices available, and then deciding on the best choice. The best choice is the one with the highest likelihood of achieving the desired outcome. The process of brainstorming is very creative. It is the main one wants people to meet – otherwise one could make the decisions on one's own. Decision-making involves making the best selection from a list of choices. The process involves evaluating the pros and cons of each choice (the consequences). The group coach has the task of ensuring the group is creative and sticks to the process that will lead to productive decision-making (par 3.4.3 and table 3.4).

Every meeting must have an action. A clear sign of a wasted meeting is for everyone to leave without any clear action planning agreed. A well-formed outcome, a clear situation and a creative decision making process, with full involvement from all people in the group, will lead to committed action planning. Groups with this kind of clarity will want to take actions.

The logical process followed so far will result in people wanting to take responsibility and recognised as having contributed to the future success of the group. Action planning consists of answering three questions:

- What actions shall we take?
- Who will take each action?

When will each of the actions be taken? A clear action plan with agreed responsibilities and periods is the sign of a productive meeting. However, the only real measure of success is if the actions actually take place and lead to the desired outcome. The desired outcome is an improved teaching and learning environment.

These strategies have a clear link to shared leadership (table 3.4). The empirical study also revealed leaders share leadership tasks at many meetings at functional schools to develop the schools further. The implementation of the OSCAR coaching model to facilitate meetings can have a clear impact on the development of the school.

6.4.4 Findings with respect to the interaction between all leaders

This was a comparative study between leaders at effective schools regarding the role of distributed leadership to ensure effective schools in South Africa. The second sub-aim of the study was to explore how distributive leadership supports and improves effective schools. This study revealed that distributed leadership supports and improves effective schools through the interaction of all leaders. Interaction occurs at effective schools through the three tiers of distributed leadership (chapter 2, figure 2.2). The implementation of the OSCAR coaching model to facilitate meetings also creates opportunities for leaders to interact (Gilbert and Whittleworth, 2009). The empirical study also proved that interaction between leaders is necessary for a school to be successful (see 5.4.4).

6.4.5 Findings with respect to sharing of leadership and delegation of leadership

The role of distributed leadership to ensure effective schools in South Africa was a comparative study between leaders at functional schools. The second aim of the study was to explore how distributive leadership supports and improves effective schools. This study revealed that distributed leadership is about the sharing of leadership tasks and not the delegation of leadership tasks (Harris, 2005; Spillane, Halverson & Diamond, 2001). Distributed leadership improves effective schools through the sharing of leadership tasks (Jameson, 2007). Choices, consequences and actions are important strategies of the Oscar coaching model to facilitate meetings and are needed when leadership is shared (par 3.4.3 and table 3.4). The empirical study revealed that 85% of the respondents agreed that the distribution of leadership is to share leadership responsibilities to achieve an organisational goal (par 5.4.6).

6.4.6 Findings with respect to ensuring effective schools

This study was a comparative study between leaders at effective schools. The researcher investigated in this study the role of distributed leadership to ensure effective schools in South Africa. The third aim of the study was to investigate how coaching can be used as an effective and successful distributed leadership strategy. In chapter 2 of the literature review, it was discovered that coaching has strong links with action learning because they are focused on problem solving and the continuous process of learning and reflection (Hafford-Letchfield, Leonard, Begum and Chick, 2007). Improvements in sharing of practice seem enhanced by peer support – since work discussion in peers involve several practitioners working together over time, the capacity for peer consultation between colleagues develops not only within the peer but also outside of the work discussion too (Warman and Jackson, 2007). More meetings that are effective will ensure schools that are more effective. Well-managed meetings create opportunities for group coaching which result in more effectiveness of whole school (Gilbert & Whittleworth, 2009).

The empirical study revealed that teachers as leaders also have an opportunity to take a leading role at the school (par 5.4.7). The implementation of the OSCAR coaching model to facilitate meetings creates opportunities to lead and improve the school together as a team (par 3.4.3). Management and class leaders explained that effective schools were ensured by shared leadership and acceptance of accountability across the school (See Appendix H – Report from Headmaster and subject leader on OSCAR coaching model to ensure effective schools).

6.4.7 Distributed leadership is about the development of coaches as a distributed leadership strategy

This study was a comparative study between leaders at functional schools. The researcher clarified the role of distributed leadership to ensure effective schools in South Africa this study. The fourth aim of the study was to explore ways in which one designed, implemented and maintained coaching as a distributed leadership strategy to ensure effective schools in South Africa. A description was given in table 2.1 regarding the human conduct of school leaders. In chapter 2.5.6, it was revealed that leaders needed to develop a high degree of teaching quality to improve and sustain the sharing of best practices and innovation (Jameson, 2007). In chapter 2.7, it was found that participating in coaching training and implementation of coaching practices, more teachers talked about teaching and learning development through coaching (Edwards and Newton, 1994b). Recent efforts to democratise schools through the distribution of leadership have included efforts to empower teachers and professionalise teaching in the area of staff development through coaching of staff (par 2.7 and par 6.3.3). The OSCAR coaching model is quite a simple framework and provides a simple structure that helps to keep the coaching process focused structured and time effective. The OSCAR coaching model works well for managers because it is simple, common sense and managers are already using it without calling it OSCAR (par 3.4.3 and table 3.4). The empirical study proved that leaders are in need of personal training to become coaches to develop the teaching profession in South Africa (5.4.8).

Only 4 out of 28 leaders indicated that they had some form of training to become coaches. 85,7% of the leaders need training to become coaches (5.4.8). The researcher implemented the OSCAR coaching model to facilitate meetings as a personal development opportunity for individual leaders.

6.4.8 Findings with respect to the OSCAR coaching model to facilitate meetings as a distributed leadership strategy to ensure effective schools

This comparative study between leaders at effective schools in South Africa clarified the role of distributed leadership to ensure effective schools in South Africa. The fifth aim of the study was to explain how a distributive leadership model could be conceptualised as leadership strategy to ensure effective schools in South Africa.

6.4.8.1 *Conceptualise how the OSCAR coaching model as a distributed leadership strategy is developed, implemented and the impact thereof*

The literature emphasised that developing and implementing the OSCAR coaching model to facilitate meetings have an impact on well-managed meetings using OSCAR:-

- saved time;
- improved motivation;
- lead to better decision making;
- quicker problem solving; and
- building stronger and more productive working relationships with team members (Gilbert and Whittle worth, 2009).

The researcher introduced the Oscar coaching model to facilitate meetings in par. 5.4.5, 5.4.6, 5.4.8 and 5.4.9). Leaders need to consider the five key elements when developing and implementing the OSCAR coaching model to facilitate meetings. The phases include outcome, situation, options to choice from, action planning and meeting review (par 3.4.3 and table 3.4).

There is evidence the OSCAR coaching model to facilitate meetings creates opportunities for group coaching. Meetings that involve all the team members and encourage participation and responsibility are more constructive than meetings where the leaders tell how to instruct and make all the decisions. Any meeting that involves discussions, problem solving and action planning is an opportunity for group coaching. Group coaching involves providing leadership without taking the reins, focusing on asking questions instead of telling and listening and building consensus (Gilbert and Whittleworth, 2009).

It is the implementation of the process and the impact on team members' reactions to process that form the basis of understanding the real purpose and the benefits of the OSCAR coaching model to facilitate meetings as a distributed leadership strategy.

6.4.8.2 *Conceptualise the purpose and the benefit of using the OSCAR coaching model to facilitate meetings as a distributed leadership strategy*

The purpose of the OSCAR coaching model to facilitate meetings is to provide a simple framework and structure that helps to keep the coaching process focused and time effective (Gilbert &Whittle worth, 2009). The benefit of the OSACR coaching model to facilitate meetings is that it works well for managers, because it is simple and easy to understand (3.4.3).

6.5 RECOMMENDATIONS

This was a comparative study between leaders at functional schools, which investigated the role of distributed leadership to ensure effective schools in South Africa. In this section, the researcher will discuss recommendations for future development of schools and education based on the themes and the findings of the literature review and the empirical study.

6.5.1 Recommendation with respect to teacher leadership

What some principals need to realise is that distribution of leadership is a strategy of shared responsibility between all teacher leaders. SMT members need to participate in decision making, as this will reduce conflict considerably (par. 2.2.1). As distribution of leadership is not common practice at most schools, principals should develop a plan together with their SMTs to take their schools to a higher level of competence by giving more accountability and responsibility to teacher leaders (par 2.2.2 and table 2.1). This study revealed that it is to a principal's advantage to involve other role-players in decision-making. A distributed leadership approach will ensure that staff will buy into a particular project and accept ownership thereof. Principals should therefore apply the principles of distributed leadership effectively by involving all teacher leaders in the curriculum planning of the school (par 2.2.3). The implementation of the OSCAR coaching model to facilitate meetings will create a great opportunity to get teacher leaders involved in the process of developing the curriculum of the school (3.4.3 and table 3.4).

6.5.2 Recommendation with respect to teamwork

It has been proven that at functional schools teamwork have positive effects for both teachers and learners; therefore, it should be encouraged in dysfunctional schools where it does not exist (table 20 and 21). To achieve this super ordinate, goals should be set for teachers at dysfunctional schools, forcing them to work together towards common goals. Goals such as punctuality and attendance of teachers can be a starting point to be implemented. Goals can be set at the first

meeting when the OSCAR coaching model is introduced at dysfunctional schools (par 3.4.3 and table 3.4).

6.5.3 Recommendation with respect to democracy and sharing of leadership

One of the aims of the study was to investigate how distributed leadership could support and improve schools to make it more effective. Recommendations are based on the findings of this study, which could lead to positive interventions on the side of all stakeholders, such as the Department of Education, principals and educators. All the above must make a joint effort to tackle the problem by developing the leadership skill of shared leadership at dysfunctional schools (par 5.4.3). There is a need to reinforce the professional code of conduct and educators should know what is expected of them (par 1.5.2). Principals at functional schools can support principals at dysfunctional schools to write, implement, monitor and evaluate such a code of conduct. The implementation could take place through the OSCAR coaching model to facilitate meetings. Every meeting will begin with a review of the successes achieved since the last meeting (par 3.4.3 and table 3.4).

6.5.4 Recommendation with respect to the interaction between all leaders

The Department of Education in KwaZulu-Natal should come up with a guideline document for school leaders that will develop and improve leaders' leadership knowledge, skills and qualities. In this guideline, the Department of Education should spell out for all leaders the effectiveness of the distributed leadership strategy through the interaction with other leaders (par 2.7, 3.2, 3.3 and 3.4). The guidelines in the document shall equip leaders with the necessary leadership skills and strategies to fulfil the leadership roles and responsibilities from time to time as professional and effective leaders.

6.5.5 Recommendation with respect to sharing of leadership and delegation of leadership

The senior management team should empower and employ shared leadership approaches instead of a top-down, control approach (par 2.5.6 and 5.4.6). To ensure shared and distributed leadership approaches, the senior management team should allow and motivate classroom leaders to participate in all types of meetings in which agreement are reached by consensus (par 5.4.6). Classroom leaders should be encouraged to work in teams rather than in isolation. All leaders should be willing to share information and resources with their colleagues in order to implement the OSCAR coaching model to facilitate meetings effectively (par 3.4.3, table 3.4 and par 5.4.5).

6.5.6 Recommendation with respect to ensuring effective schools

It is recommended that principals be provided with training and development in evaluating the effectiveness of coaching models by reinforcing teamwork, building trust and facilitating collaborative decision making across the school and within departments (par 5.4.1). Principals need to support their leaders to implement the OSCAR coaching model to facilitate meetings effectively (par. 3.4.3 and table 3.4). Then they need monitoring and evaluate the effectiveness of coaching model. After the evaluation, further actions need to be implemented to make the programme more effective (par 3.4.3 and table 3.4).

6.5.7 Recommendation with respect to the development of coaches as a distributed leadership strategy

If learning is a life-long pursuit and if the principal goal is to improve the quality of teaching and learning at functional schools, class leaders continuously need to be leaders in their classes (par 5.4.1). Ways in which leaders can develop themselves are through on-going developmental opportunities such as workshops; in-service training and conferences (par 2.5.6). The development of leadership skills is essential if functional schools wish to maintain the increased achievement of learners. Professional development adds meaning to high performance expectations and it contributes towards academic excellence.

Principals should enable educators to become agents, rather than objects of staff development. They should create opportunities for staff development in various forms, for example, peer coaching (par 3.4.5); coaching of new educators (par 3.5.3); collaborating with all leaders (par 2.5.6), group coaching (table 3.4) and willingness to share information and ideas with all staff members during OSCAR coaching meetings to facilitate meetings (table 3.4).

6.5.8 Recommendation with respect to the OSCAR coaching model to facilitate meetings as distributed leadership strategy to ensure effective schools

The timing of in-service training is also a huge problem. To curb this perennial problem, it is recommended that in-service training be conducted monthly after school for an hour (table 3.4). The training manual is included for future use by schools (Appendix H). Schools can cancel normal planning sessions and use the time for whole-school development. Schools can use these times to reflect on the OSCAR coaching model to facilitate meetings and review successes with whole-school teams since the last meeting (par 3.5.3). Whole schools can work in teams and develop the next actions on how to improve the school further. The group coach just asks questions and listens to the responses. Teams then develop actions from what has been heard (par 3.5.3). This is where the strengths of coaching lie. Most educators, including senior management, must be available to attend in-service training sessions. In fact, senior management members should be part of each in-service training session so that they are aware of the latest development in education (table 3.4).

6.6 RECOMMENDATIONS FOR FURTHER RESEARCH

- Both qualitative and quantitative investigations should be pursued with school principals and the effect of coaching and whole-school development by gathering data through participant observations, questionnaires and in-depth interviews.
- The introduction of a coaching module as part of the BEd.(Honors) degree in Education Management. The coaching model will enhance the competence of the leader. Schools will have qualified coaches on their leadership teams and this can be beneficial to all schools for management, training and development of all leaders within schools.
- A mixed-method study could be conducted to determine whether there is any significant relationship between functional and dysfunctional schools with respect to sharing of leadership as a distributed strategy to ensure effective middle leaders.
- A quantitative study could be conducted to investigate the distributed leadership qualities that middle leaders may require to lead their departments and their year groups.
- The impact of planning, monitoring and evaluation of developing teaching and learning within the intermediate phase through the OSCAR coaching model to facilitate meetings.

A qualitative-quantitative study to investigate the impact of distributed leadership to ensure an effective assessment for a learning policy in a PYP (Primary Year Programme) curriculum in the Middle East.

6.7 CONTRIBUTION OF THE STUDY TOWARDS THE THEORY AND PRACTICE OF EDUCATION MANAGEMENT AS A DISCIPLINE

This thesis used a behaviourist paradigm to focus on the role of distributed leadership to ensure effective schools in South Africa through a comparative study. The variables were theoretically evaluated in chapters 2 and 3 and the results of the empirical investigations were reported in chapter 5.

Throughout this study, the focus was on determining the role of distributed leadership to ensure effective schools in South Africa. The results of the empirical study suggested that distributed leadership does exist at functional schools, and a decision was taken to explore the OSCAR coaching model further to facilitate meetings as distributed leadership strategy.

The theoretical clustering of the leadership styles items and the distributed leadership model resulted in the identification of the shared leadership with elements of democratic leadership as significant contributors to the distribution of leadership and the OSCAR coaching model to facilitate meetings. This information is of importance for educational managers as they will be able to provide schools with suggestions for developmental programmes for leaders and managers in order to increase positive perceptions regarding the role of distributed leadership to ensure effective schools in South Africa.

Recommendations were also provided concerning practical implications for Educational Managers and organisations based on the results of the study. This study contributed towards building research evidence regarding the role of distributed leadership to ensure effective schools in South Africa.

6.8 CONCLUSION

The nature of the research project was exploratory and provided insights into the role of distributed leadership to ensure effective schools in South Africa through the OSCAR coaching model to facilitate meetings. The study has highlighted that sharing of leadership with a democratic approach is distributed leadership strategies to ensure effectiveness. The OSCAR coaching model to facilitate meetings advocates a systematic problem-solving process in which the coaching leader facilitates the enhancement of teaching and learning. When coaching opportunities arise during the day, the leader uses facilitation skills to engage the employee in the problem-solving process.

The research findings have added to the body of knowledge surrounding the OSCAR coaching model to facilitate meetings, by highlighting the core coaching skills that are most likely to promote a successful coaching outcome. The challenge that lies ahead is for leaders to acquire these coaching skills so that they can make the transition to become a coaching leader and develop the school in such a way. Finally, areas for future research have been recommended to help improve our understanding and knowledge of coaching.

7. REFERENCE LIST

- Anderson, E.M. & Shannon, A.L. 1988. Towards a conceptualisation of mentoring. *Journal of Teacher Education*, 39(1):38-42.
- Angelle, P.S. 2010. An school perspective of distributive leadership: a portrait of a middle school, *RMLE Online*, 33(5):1-16.
- Association of Teachers and Lecturers. 2007. *Effective Leadership*. ATL: The Education Union.
- Astin, A.W. & Astin, H.S. 2000. *Leadership reconsidered: engaging higher education in social change*. Battle Creek, MI: W.K. Kellogg Foundation.
- Avolio, B.J., Kahai, S. & Dodge, G.E. 2001. E-leadership: implications for theory, study, and practice. *Leadership Quarterly*, 11:615-668.
- Argyris, C., & Schon, D. A. 1996. *Organizational learning II*. Reading, MA: Addison Wesley.
- Babbie, E. & Mouton, J. 2000. *The practice of social research*. Cape Town: Oxford University Press.
- Babbie, E. & Mouton, J. 2002. *The practice of social study*. Cape Town: Oxford University Press.
- Badaracco, J. 2001. *Beyond heroic moral leadership*. [http://www.ksg.harvard.edu/leadership/beyond heroic moral leadership.html](http://www.ksg.harvard.edu/leadership/beyond_heroic_moral_leadership.html). Assessed on 8 January 2011.
- Bates, R. 1992. *Leadership and school culture*. Seville : ERIC Document Reproduction. Service No.353636.
- Bell, S. 1998. Self-reflection and vulnerability in action study: Bringing forth new worlds in our learning. *Systemic Practice and Action Study*, 11(2):179-191
- Bennett, N., Wise, C., Woods, P. & Harvey, J. 2003. *Distributed leadership*. Full Report. Oxford: National College for School Leadership.

- Bennis, W.G., Benne, K.D. & Chin, R. eds. (1961). *The planning of change*. New York: Holt, Rinehart & Winston.
- Bernard., H.R. 2000. *Social Study Methods: Quantitative and Qualitative Approaches*. London: Sage Publications.
- Best, J.W., & Kahn, J.V. 2003. *Study in Education*. Boston: Library of Congress Cataloguing In Publication Data.
- Blasé, J. & Blasé, J. 1998. Inquiry and collaboration: supporting the lifelong study of learning and teaching. *International Electronic Journal for Leadership in Learning – IEJLL*, 2(7). [Online]. Available at <http://iejll.synergiesprairies.ca/iejll/index.php/iejll/article/view/20> (Accessed: 20 August 2011).
- Blasé, J. & Blasé, J. 2001. *Empowering teachers: what successful principals do*. 2nd edition. Thousand Oaks, CA: Corwin.
- Block, P. 1996. *Stewardship: Choosing service over self-interest*. San Francisco: Berrett-Koehler.
- Bogdan, R.C. & Biklen, S.K. 1992. *Qualitative study for education: An introduction to theory and methods*. Boston: Allyn & Bacon.
- Bolden R. 2004. *What is Leadership? South West Leadership Report 1*. Exeter: University of Exeter Centre for Leadership Studies.
- Bolden, R., Gosling, J., Marturano, A., and Dennison, P. (2003). *A Review of Leadership Theory and Competency Frameworks* [On-line]. UK: Available: http://www.leadershipstudies.com/documents/mgmt_standards.pdf. Accessed April 14, 2011.
- Bowers, D. & Seashore, S. 1966. Predicting school effectiveness with four-factor theory of leadership. *Administrative Science Quarterly*, 11: 268-93.
- Breakwall, G.,M., & Hammond, S. & Fife-Schaw, C. 2000. *Study methods in psychology*. (2nd Edition). London: Sage

- Brink, H.I. 1996. *Fundamentals of Social study methodology for health care for professionals*. Cape Town: Juta.
- Brown, M.E. & Gioia, D.A. 2002. Making distributed leadership in an online division of an offline organization. *The Leadership Quarterly*, 13(4):397–419.
- Buckingham, M. & Clifton, D. 2001. *Now, discover your strengths*. London: The Free Press.
- Burns, N., & Grove, S.K. 1993. *The practice of nursing study: Conduct, critique and utilization*. (2nd Edition.). Philadelphia: W.B. Saunders.
- Bush, T. & Odura, K.T. 2006. New Principals in Africa: preparation, induction and practice. *Journal of Educational Administration*, 44:359-375.
- Carson, J.B., Tesluk, P.E. & Marione, J.A. 2007. Shared leadership in teams: an investigation of antecedent conditions and performance. *Academy of Management Journal*, 50:1217-1234.
- Carter, A. 2001. *Executive coaching: inspiring performance at work*. UK: Grantham Book Services.
- Chamberland, L. 2009. *Distributed leadership: developing a new practice. An action study*. Doctoral Thesis. University of California, Santa Cruz. [Online]. Available at <http://www.grin.com/en/doc/273084>, pdf. (Accessed on 10 July 2011).
- Charles, C.M. 1998. *Elementary Classroom Management*. New York: Longman.
- Clutterbuck, D. 2001. *Everyone Needs A Mentor*, 3rd edition. London: Chartered Institute of Personnel and Development.
- Cohen, L., Manion, L. & Morrison, K. 2000. *Study Methods in Education*. London: Routledge Falmer.

- Coleman, M. 2003. Theories of leadership. In: M. Thurlow, T. Bush, & M. Coleman, *Leadership and strategic management in South African schools*. London: The Commonwealth Secretariat. pp. 155–172.
- Cope, M. 2004. *The seven Cs of coaching. The definitive guide to collaborative coaching*. Great Britain: Pearson Education Limited.
- Copland, M.A. 2003. Leadership of inquiry: building and sustaining capacity for school improvement. *Educational Evaluation and Policy Analysis*, 25(4): 375–395.
- Costa, A.L. & Garmston, R.J. 1994. *Cognitive coaching: a foundation for renaissance schools*. Massachusetts: Christopher-Gordon Publishers Inc.
- Creasy, J. & Paterson, F. 2005. *Leading coaching in schools*. Nottingham: NCSL.
- Cresswell, J.W. 1994. *Study Design: Qualitative, Quantitative and Mixed Methods Approaches*. London: Sage Publishers.
- Creswell, J.W. 2003. *Qualitative, quantitative and mixed method approaches*. 2nd edition. Sagan: Sage.
- Creswell, J.W. 2008. *Study design*. Sagan: Sage.
- Crowther, F., Hann, L. & McMaster, J. 2001. *School innovation: Pathway to the knowledge society*. Canberra, Australia: Australian Commonwealth Department of Education, Training and Youth Affairs.
- Crowther, F., Kaagen, S. S., Ferguson, M., & Hann, L. (2002). *Developing teacher leaders: How teacher leadership enhances school success*. Thousand Oaks, CA: Corwin Press.
- Cunnigham, I. & Hyman, J. 1995. Transforming the HRM vision into reality: The role of line managers and supervisors in implementing change. *Employee Relations*, 17(8):5–20.

- CUREE. 2005. *Mentoring and coaching: CPD capacity building project*. Coventry: CUREE
- Danielson, C. 2007. The many faces of leadership. *Educational Leadership*, 65(1).
- Darling-Hammond, L. & McLaughlin, M. 1996. Policies that support professional development in an era of reform. In: M. Mchughlin, & I. Oberman, I.(eds.). *Teacher learning: new policies, new practices*. New York: Teachers College Press.
- Day, C., Harris, A. & Hadfield, M. 2001. Grounding knowledge of schools in stakeholders' realities: a multi-perspective study of effective school leaders. *School leadership and management*, 21(1):19-42.University of Nottingham.
- De Vos, A.S. 1998. *Study at grass roots. A primer for caring professions, (2nd Edition)*. Pretoria: Van Schaik.
- De Vos, A.S., Strydom, H., Fouché, C.B. & Delport, C.F.L. (eds.). 2002. *Study at grass roots: for the social sciences and human services profession*. Pretoria: Van Schaik.
- Department for Education and Skills. 2004. *National conversation about personalised learning*. London: DfES.
- Department of Education, Science and Training.2003. *National Quality Schooling Framework* (<http://www.nqsf.edu.au>).
- Department of Education. 2008. *Understand school leadership and governance in the South African context*. Tshwane: Department of Education.
- Drath, W.H., &Palus. C. J. 1994. *Making common sense: Leadership as meaning – making in a community of practice*. Greensboro, NC: Center for Creative Leadership.
- Drucker, P. 1985. *Innovation and entrepreneurship: practice and principles*. New York: Harper & Row.

- Duigan, P. & Macpherson, R. 1992. Creating new knowledge about school leadership. In: P. Duigan & R. Macpherson (eds). *School leadership: a practical theory for new administrators and managers*. Lewes: Falmer. pp. 1-17.
- Du Toit, F. 1999. *Study Guide. Educational management*. Pretoria: Vista University.
- Edmondson, A.E. 2002. Psychological safety and learning behavior in work teams. *Administrative Science Quarterly*, 44:350-383.
- Edwards, J.L., & Newton, R.R. 1994. *The effects of cognitive coaching and teacher efficacy and thinking about teaching*. Paper presented at the Annual Meeting of the American Education and Study Association. San Francisco, CA.
- Earley, P. & Weinding, N. 2004. *Understanding school leadership*. London: Paul Chapman.
- Eisenhart, M. & Barko, H. 1993. *Designing classroom study*. Boston: Allyn and Bacon.
- Elmore, R. 2000, *Building a new structure for school Leadership*, Washington DC: The Albert Shanker Institute.
- Engeström, Y. 1999. Expansive visualization of work: An activity theoretical perspective. *Computer Supported Cooperative Work*, 8, 63-93.
- Engestrom, Y., Miettinen, R., & Punamaki, R.L. (Eds.). 1998. *Perspectives on activity theory*. Cambridge, UK: Cambridge University Press.
- Ferrance, E. 2000. *Action study*. Providence, RI: LAB at Brown University, The Education Alliance.
- Fraenkel, J. R. & Wallen, N. E. 1993. *How to design and evaluate study in Education*. New York: McGraw-Hill Inc.

- Freas, A.M. 2000. Coaching executives for business results. In: M.L. Goldsmith & A.M. Freas (eds.). *Coaching for leadership*. San Francisco: Jossey Bass.
- Frisch, M.H. 2001. The emerging of the internal coach. *Consulting Psychology Journal: Practice and Study*, 53(4):240-250.
- Germann, P. 2002. *Developing internal coaches: An investment that yields business results*. London: MDA Consulting Group.
- Gilbert, A. & Whittleworth, P. 2009. *The OSCAR coaching model. Simplifying workplace coaching*. Monmouthshire: Worth Consulting Ltd.
- Gladstein, D.L. 1984. Groups in context: a model of task group effectiveness. *Administrative Science Quarterly*, 29(4):499-517.
- Glew, D. J., O'Learly-Kelley, A. M., Friggin, R.W. & Van Fleet, D.D. 1995. Participation in organizations: A preview of the issues and proposed framework for future analysis. *Journal of Management*, 21: 395–421.
- Glanz, J. 2003. *Action study: an educational leader's guide to school improvement*. Norwood, MA: Christopher-Gordon Publishers, Inc.
- Gordon, R.D. 2002. Conceptualizing leadership with respect to its historical-contextual antecedents to power. *Leadership Quarterly*, 13(2):151–167.
- Gorton, R., Alston, J. & Snowden, P. 2007. *School leadership and administration: important concepts, case studies and simulations, 7th edition*. New York: McGraw-Hill.
- Grace, G. 1995. *School leadership: beyond educational management: an essay in policy scholarship*. Lewes: Falmer.
- Grant, A. 2003. The impact of life coaching on goal attainment, meta-cognition and mental health. *Social Behavior and Personality*, 31(3):253-264.

- Grant, C. 2006. Teacher leadership: some South African voices. *Education Management, Administration and Leadership*, 34(4):511– 532.
- Greenberg, J. & Baron, A. 1993. *Behaviour in schools: understanding and managing the human side of work* (4th edition). Englewood Cliffs, NJ: Prentice Hall.
- Gronn, P. 2000. Distributed properties: a new architecture for leadership. *Educational Management and Administration*, 28(3):317–381.
- Gronn, P. 2002. Distributed leadership as a unit of analysis. *Leadership Quarterly*, 13, 423-451.
- Gunter, H. & Ribbens, P. 2003. Studies in future leadership. *Leadership Studies in Educational Management and Administration*, 30(4):387-416.
- Gunter, H.M. 2005. *Leading teachers*. London: Continuum.
- Hackman, R.J. & Wageman, R. 2005. A theory of team coaching, *Academy of Management Review*, 30(2):269-287.
- Hackman, R.J. 1987. The design of work teams. In: J. Lorsch, (Hrsg): *Handbook of school behavior*. Englewood Cliffs, NJ: Prentice- Hall.
- Hafford-Letchfield, T., Leonard, K., Begum, N. & Chick, N.F. 2007. Coach mentoring as a developmental tool in the workplace. In: T. Hafford-Letchfield, K. Leonard, N. Begum & N.F. Chick (eds.). *Leadership and management in social care*. London: Sage.
- Hakim, C. 2000. *Study design: successful designs for social and economic study*. New York: Routledge.
- Hall, L. 2005. *Accentuate the positive. Coaching at work. Special Launch Issue*, 31-32.
- Habermas, J. 1984. *The theory of communicative action, reason and the rationalization of society*. (Translated by T. Mc-Carthy). Boston: Beacon Press.

- Hargrove, R. 2003. *Masterful Coaching (Revised Edition)*. San Francisco: Josey-Bass Pfeiffer.
- Harris, A. & Lambert, L. 2003. *Building leadership capacity for school improvement*. Milton Keynes: Open University Press.
- Harris, A. & Lambert, L. 2003. *What is leadership capacity?* Cranfield: National College for School leadership.
- Harris, A. 2002. *School improvement: what's in it for schools?* London: Falmer Press.
- Harris, A. 2005. Leading or misleading? Distributed leadership and improvement. *Journal of Curriculum Studies*, 37(3):255-265, Curriculum Leadership Website [Online]. Available at <http://curriculum.edu.au/leader>. (Accessed on 9 August 2010).
- Harris, A. 2005. *Crossing boundaries and breaking barriers: distributing leadership in schools*. Kent: Specialist Schools Trust.
- Hatcher, R. 2005. The distribution of leadership and power in schools. *British Journal of Sociology of Education*, 26(2):253-267.
- Heifetz, R. 1994. *Leadership without easy answers*. Cambridge: Belnap Press.
- Henning, E., Van Rensburg, W. & Smit, B. 2004. *Finding your way in qualitative study*. Pretoria: Van Schaik.
- Henning, K. 2005. Loyalty, paternalism, and rights: client counseling theory and the role of the child's counsel in delinquency cases. *81 Notre Dame L. Rev.*, 245: 317-318.
- Hersey, P., Blanchard, K. H. & Johnson, D. E. 2001. *Management of school behaviour: leading human resources*. New Jersey: Prentice-Hall.
- Hilsenbeck, T. & Neubert, B. 2006. *Mythos Team: Ein Reader zu den Erkenntnissen der psychologischen Kleingruppenforschung* [Online]. Retrieved from: <http://www.aperioonline.de> [Accessed 11 December 2011].

- Holloway, I. & Wheeler, S. 1996. *Qualitative study for the nurse*. London: Sage.
- Hopkins, D. & Higham, R. 2007. System leadership: mapping the landscape. *School Leadership and Management*, 27(2):147-166.
- Horn, R.A. 2002. Differing perspectives on the magic of dialogue: Implications for a scholar-practice leader. *Scholar-Practitioner Quarterly*, 1(2):83-102.
- Hoskings, D.M. 1988. Organizing, leadership and skilful process. *Journal of Management Studies*, 25:147–166.
- Hoskings, D.M. 1991. Chief executives organising processes, and skill. *European Journal of Applied Psychology*, 41:95–103.
- House, R. 1971. A path-goal theory of leader effectiveness. *Administrative Science Quarterly*, 16: 8-12.
- House, R.J. & Aditya, R.N. 1997. The social scientific study of leadership: quo vadis? *Journal of Management*, 23:409–473.
- Hulpia, H., DeVos, G. & Van Keer, H. 2010. The influence of distributed leadership on teachers' school commitment: a multilevel approach. *The Journal of Educational Study*, 103(1):40-52. [Online]. D.O.I: 1080/00220670903231201 (Accessed: 17 August 2011).
- Institute for Educational Leadership. 2001. *Leadership for Learning of learners. Redefining the teacher as leader*. Washington DC.
- Internal Coach Federation. 2002. *Executive summary: who, what, where, when and how*. [http://www.coachfederation.org/eweb/docs/exec. Summary – 2002.pdf](http://www.coachfederation.org/eweb/docs/exec.Summary-2002.pdf) [Accessed 17 November].
- James, W. 2000. *Report: values, education and democracy*. Pretoria: Minister of Education.
- Jameson, J. 2007. *Investigating collaborative leadership for communities of practice in learning and skills*. Practitioner Study Programme 2006-07. Lancaster University: CEL.

- Jansen, J. & Taylor, N. 2003. Educational change in South Africa 1994-2003: case studies in large-scale education reform. *Country Studies – Education Reform and Management Publication Series*, 2(1), Oct 2003, World Bank: USA.
- Johnson, D.W. & Johnson F.P. 2003. *Joining together: group theory and group skills*, 8th edition. Boston: Pearson Education Inc.
- Jenlink, P.M. 2002. The scholar practitioner as bricoleur. *Scholar Practitioner Quarterly*, 1(2):3-6.
- Joyce, B. 2004. How are professional learning communities created? History has a few messages. *Phi Delta Kappa*, 86(1), 76-83.
- Kampa-Kokesch, S., & Anderson, M.Z. 2007. Executive coaching: A comprehensive review of the literature. In: R.R Kilburg & R.C. Diedrich (eds.). *The wisdom of coaching: Essential papers in consulting psychology for a world of change*. Washington: American Psychological Association.
- Kampa-Kokesch, S., & White, R.P. 2002. The effectiveness of executive coaching: What we know and what we still need to know. In: R.L. Lowman (ed.). *The handbook of school consulting psychology*. San Francisco: Jossey–Bass.
- Kaplan, B. & Maxwell, J.A. 1994. *Qualitative Study Methods for Evaluating Computer Information System in Evaluating Health Care Information Systems: Methods and Applications*. San Francisco Sage: Thousand Oaks.
- Kaplan, R.S. & Norton, D.P. 1996. *The balanced scorecard: translating strategy into action*. Boston: Harvard Business School Press.
- Katzenbach, J. & Smith, D. 1994. *The Wisdom of Teams*. New York: Harperbusiness.

- Kvale, S. 1983. The qualitative study interview: A phenomenological and a hermeneutical mode of understanding. *Journal of Phenomenological Psychology*, 14: 171-196.
- Kelly, A. 2002. *Team talk: sharing leadership in primary schools*. Available from NCSL website at www.nsl.org.uk/studyassociates. Assessed on 13 March 2010.
- Khoza, R. 2005. *Let Africa lead*. Johannesburg: Vezubuntu Publishing (Pty)Ltd.
- Killburg, R.R. 2007a. Towards a conceptual understanding and definition of executive coaching. In: R.R Kilburg & R.C. Diedrich (eds.). *The wisdom of coaching: Essential papers in consulting psychology for a world of change*. Washington: American Psychological Association. pp. 21–30.
- Knights, D. & Willmott, H. 1992. Conceptualizing leadership processes: A study of senior managers in a financial services company. *Journal of Management Studies*, 29:761–82.
- Krause, L. & Powell, R. 2002. Preparing school leaders in post-apartheid South Africa: a survey of leadership preferences of principals in the Western Cape. *Journal of Leadership Studies*, 8(3):63–78.
- Krefting, L. 1991. Rigour in qualitative study: the assessment of trustworthiness. *The American Journal of Occupational Therapy*, 45 (3): 214-222.
- Krueger, R. A. 2000. *Focus Groups: A Practical Guide for Applied Study*. London: Sage.
- Lambert, L. 2005. Leadership for lasting reform. *Educational Leadership*, 62(5):62-65.
- Lashway, L. 2003. Distributive leadership. *Study Roundup*, 19:1–4.
- Latuour, B. 1987. *Science in action: how to follow scientists and engineers through society*. Cambridge, MA: Harvard University Press.

- Le Compte, M. & Preissle, J. 1993: *Ethnography and qualitative design in educational study*. London: Academic Press Inc.
- Leithwood, K. & Riehl, C. 2005. What we know about successful school leadership. In: W. Firestone & C. Riehl (eds.). *New Agenda: Direction for study on educational leadership*. New York: Teacher College Press. pp. 22-47.
- Leithwood, R. & Riehl, C. 2003. *What we know about successful school leadership*. Philadelphia: Temple University.
- Levine, A. 2005. *Educating school leaders*. Washington, DC: The Education School Projects.
- Lewis, M. & Andrews, D. 2004. *Building sustainable futures: Emerging understandings of the significant contribution of the professional learning community*. *Improving Schools* 7 (2): 129-150
- Lieberman, A., Saxl, E.R. & Miles, M.B. 2000. Teacher leadership: ideology and practice. *The Jossey-Bass Reader on Educational Leadership*. San Francisco: Jossey-Bass. pp. 339–345.
- Lightfoot, S.L. 1983. *The good high school*. New York: Harper and Row.
- Lincoln, Y.S. & Guba, E.G. 1985. *Naturalistic Inquiry*. Newbury Park: Sage.
- Lindsay, R., Robins, K. & Terrell, R. 2003. *Cultural proficiency: A manual for school leaders*. Thousand Oaks: Corwin Press.
- Loeser, J.M. 2008. School leadership. *Ebsco Study Starters: HertsEbsco Publishing*
- Louis, K., Leithwood, K., Wahlstrom, K., & Anderson, S. 2010. *Investigating the Links to Improved Learning of learners*. New York: The Wallace Foundation.
- Love, J. R. 1994. *Liberating leaders from the superman syndrome*. Lanham: University Press.

- MacBeath, J. 2005. Leadership as distributed: a matter of practice. *School leadership and Management*, 25(4):349-366.
- MacBeath, J., Oduro, G.K.T. & Waterhouse, J. 2004. *Distributed leadership*. An unpublished study report. Submitted at the National College for School Leadership.
- MacBeath, J., Oduro, G.K.T. & Waterhouse, J. 2004. *Distributed Leadership*. An unpublished study report submitted to the National College for School Leadership.
- Manz, C.C. & Sims, H.P. (Jr). 1991. Super leadership: beyond the myth of heroic leadership. *School Dynamics*, 19(4):18–35.
- Marshak, R.J., & Katz, J.H. 2001. Keys to unlocking covert processes. *OD Practitioner*, 33(2): 109.
- Marshall, C. & Rossman, G.B. 1995. *Designing qualitative study*. Thousand Oaks: SAGE Publishers.
- Maxwell, J.A. 1996. *Qualitative study and interactive approach*. California: Sage.
- Maykut, P. & Morehouse, R. 1994. *Beginning qualitative study*. London: The Falmer Press.
- Mc Millan, J.H. & Schumacher, S. 1993. *Study in Education*. USA: Longman.
- Mc Millan, J.H. & Schumacher, S. 1997. *Study in Education: A Conceptual Introduction*. New York: Harper Collins College Publishers.
- Mc Millan, J.H. & Schumacher, S. 2001. *Study in Education* (3rd edition). New York: Harper Collins.
- McLennan, A. & Thurlow, M. 2003. The context of education management in South Africa. In: M. Thurlow, T. Bush & M. Coleman (eds.). *Leadership and strategic management in South African schools*. London: The Commonwealth Secretariat.

- McLennan, A. 2000. *Education governance and management in South Africa*. Unpublished Ph.D. thesis, University of Liverpool.
- Mestry, R. & Grobler, B. 2002. The training and development of principals in the management of teacher. *International Studies in Educational Administration*, 30(3):21–34.
- Mestry, R. & Prakash, S. 2007. Continuing professional development for principals: a South African perspective. *South African Journal for Education*, 27(3):477–490.
- Miles, K. H., Odden, A., Archibald, S., Fermanich, M. & Gallagher, H. A. 2002. *A cross district analysis of professional development expenditures in four urban districts*. Madison, WI: University of Wisconsin-Madison, Wisconsin Center for Education. Study, Consortium for Policy Study in Education.
- Morse, J.M. 1994. *Critical Issues in Qualitative Study methods*. London: Sage.
- Mourshed, M., Chinezi, C., & Barber, M. 2010. *How the world's most improved systems keep getting better*. London: McKinsey and Company.
- Mouton, J. & Marais, H.C. 1993. *Basic concepts in the methodology of socialscience*. Pretoria: Human Science Study Council.
- Mouton, J. 2001. *How to succeed in your masters and doctoral studies*. Pretoria: Van Schaik.
- Muijs, D. & Harris, A. 2003. *Teacher leadership – improvement through empowerment*. *Educational Management & Administration*, 31(4):437–448.
- Muller, J. & Marais. 2004. *Reading Bernstein, studying Bernstein*. London: Routledge Falmer.
- Murgatroyd, S. & Morgan, C. 1993. *Total quality management and the school*. Buckingham: Open University Press.

- Murphy J., & Datnow A. (eds.). 2003. *Leadership for school reform: Lessons from comprehensive school reform designs*. Thousand Oaks, CA: Corwin Press.
- National College for School Leadership. 2004. *Distributed leadership in action*. Nottingham.
- Neuman, W.L. 1997. *Social study methods: qualitative and quantitative approaches*. Oxford: Blackwell.
- Neumans, W.L. 2003. *Social study methods*. 5th edition. USA: Pearson Education INC.
- Nichols, A. 2000. *Strategic Planning in schools: some practical techniques*. USA: Houghton Mifflin Company.
- Odden, A. 2009. *10 strategies for Doubling Learner Performance*. London, UK: Corwin.
- Owen, R. 2007. *School behaviour in education*, 9thed. Boston: Pearson.
- Parry, K.W. & Bryman, A. 2006. Leadership in organizations. In: S. Clegg, C. Hardy, T. Lawrence & W. Nord (eds.), *The Sage handbook of organization studies*. 2nd ed. London: Sage. pp. 447–468.
- Parry, K.W. 1998. Grounded theory and social process: A new direction for leadership study. *Leadership Quarterly*, 9:85–105.
- Parsloe, E. 1992. *Coaching, Mentoring and Assessing: a Practical Guide to Development Confidence*. London: Kogan Page.
- Parsloe, E. 1999. *The manager as coach and mentor*. London: Institute of Personnel & Development, pp. 8–34
- Pea, R.D. 1993. *Practices of distribution intelligence and designs for education. Psychological and educational considerations*. New York: Cambridge University Press.

- Pearce, C.L. & Sims, H.P. 2000. Shared leadership: towards a multi-level theory of leadership. In: D.A. Johnson & S.T. Beyerlein (eds.). *Advances in interdisciplinary studies of work teams*, vol. 7. Team Development. New York: Elsevier Science. pp. 115–139.
- Pearsall M.J. & Ellis, A.P.J. 2006. The effects of critical team member assertiveness on team performance and satisfaction. *Journal of Management*, 32(4):575.
- Penuel, W.R., Frank, K.A. & Krause, A. 2006. The distribution of resources and expertise and the implementation of school wide reform initiatives. *A Digital Library*. Available at [Accessed on 23 December 2011].
- Poggenpoel, M. 1998. *Data analysis in qualitative study*. In: A.S. de Vos (Ed). *Study at Grass roots: A primer for the caring professions*. Pretoria: Van Schaik. pp.334-353
- Pogrow, S. 1996. *Reforming the winnable reformers – why education reformers almost always end up making things worse*. Bloomington: Phi Delta Kappan, p. 657.
- Pounder, D., Ogawa, R. & Adams, E. 1995. Leadership as an organization-wide phenomenon: its impact on school performance. *Educational Administrative Quarterly*, 31(4):564-88.
- PricewaterhouseCoopers. 2007. *Independent study into school leadership*. Nottingham: DFES.
- Pushpanadham. K. 2006. Educational Leadership for School-based Management. *ABAC Journal*, 26(1):41-48.
- Raelin, J.A. 2006. The role of facilitation in praxis. *School Dynamics*, 35(1):83–95.
- Renshaw, P. 2008. *REFLECT: Creative Partnerships National Co-mentoring Programme. Executive Summary*. Gateshead: The Sage Gateshead.

- Republic of South Africa. 1998. *Employment of Teacher, Act (EEA)*, No. 76 of 1998.
- Roberts, A. 2000. Mentoring re-visited: a phenomenological reading of the literature, in *Mentoring and Tutoring*, 8(2): 145–170.
- Rhodes, C.P. & Beneicke, S. 2002. Coaching, mentoring and peer networking: Challenges for the management of teacher professional development in schools, *Journal of In-Service Education*, 28(2):297-309.
- Ribbens, P. & Gunter, H. 2004. Mapping leadership studies in education. *Educational Management and Administration*, 30(4):359-385.
- Ritchie, R. & Woods, P.A. 2007. Degrees of distribution: towards an understanding of variations in the nature of distributed leadership in schools. *School Leadership and Management*, 27(4):363–381.
- Rosenholtz, S. 1989. *Teachers' workplace: the social school of schools*. New York: Longman.
- Ruff, W.G., & Shoho, A.R. 2005. Understanding instructional leadership through the mental models of three elementary school principals. *Educational Administration Quarterly*, 41, 554-577.
- Rutter, M., Maugham, B., Mortimer, P., & Smith, A. 1979. *Fifteen thousand hours in secondary schools and their effects on children*. Cambridge, USA: Harvard University
- Sagor, R. 2000. *Guiding School Improvement with Action Study*. Alexandria, Virginia: Association for Supervision and Curriculum Development.
- Sayed, Y. 2000. Democratising education in a decentralised system: South African policy and practice. *Compare*, 32(1):35–46.
- Schnrink, W.J. 1998. *Participant Observation*, pp. 277-296. In: A.S. de Vos (ed.). *Study at grass roots: A primer for caring professions*. Pretoria: Van Schaik.

- Scholl, W. 2005. Grundprobleme der Teamarbeit und ihre Bewältigung: Ein Kausalmodell, In: M. Högl & H.G. Gemünden (Hrs.), *Management von Teams. Theoretische Konzepte und empirische Befunde*. 3rd ed. Wiesbaden: Gabler.
- Schrurink, E.M. & Poggenpoel, M. 1998. *Psychology and introduction*. Cape Town: Oxford University.
- Schurink, W.J., Schurink, E.M. & Poggenpoel, M. 1998. Focus group interviewing and audio-visual methodology in qualitative study. In: A.S. de Vos (ed.). *Study at grass roots. A primer for the caring professions*. Pretoria: Van Schaik.
- Scott, D. & Usher, R. 2000. *Studying Education Data, methods and Theory in Educational Enquiry*. London: Cassell
- Senge, P.M. 1990. *The fifth discipline: The art and practice of the learning school*. New York: Doubleday.
- Sergiovanni, T. 1994. *Building community schools*. San Francisco: Jossey-Bass.
- Sharratt, L. & Fullan, M. 2009. *Realization: The change imperative for deepening district-wide reform*. Thousand Oaks, CA: Corwin.
- Shaughnessey, J.J. & Zechmeister, E.B. 1997. *Study Methods in Psychology*. Boston: McGraw-Hill.
- Shaw, I.F. 1999. *Qualitative Evaluation*. London: Sage.
- Sherer, J.Z. 2004. *Distributed leadership practice: the subject matters*. Paper presented at the Annual Meeting of the American Educational Study Association, San Diego, CA, on 15 April 2004.
- Sillins, H. & Mulford, W. 2002. *Leadership and school results*. Dordrecht, The Netherlands: Kluwer.

- Silverman, D. 1993. *Interpreting qualitative data. Methods for analysing talk, text and interaction*. London: Sage.
- Sims, H.P. & Lorenzi, P. 1992. *The new leadership paradigm*. Newbury Park: Sage.
- Smylie, M., Conley, S. & Marks, H.M. 2002. Exploring new approaches to teacher leadership for school improvement. In: J. Murphy (ed). *The educational leadership challenge: redefining leadership for the 21st century*. Chicago: University of Chicago Press. pp. 162-188.
- Southworth, G. 1998. *Leading improving primary schools*. London, UK: Falmer Press.
- Spillane, J. 2006. *Distributed leadership*. San Francisco, CA: Jossey-Bass.
- Spillane, J., Halverson, R. & Diamond, J. 2001. *Towards a theory of leadership practice: a distributed perspective*. North-Western University, Institute for Policy Study Working Paper.
- Spillane, J., Halverson, R. & Diamond, J.B. 2004. Investigating school leadership practice: a distributed perspective. *Educational Researcher*, 30(3):23-28.
- Spillane, J.P. & Diamond, J.B. 2007. *Distributed leadership in practice*. New York: Teacher College Press.
- Spillane, J.P., Halverson, R. & Diamond, J.B. 2004. Towards a theory of leadership practice: a distributed perspective. *Journal of Curriculum Studies*, 36(1):3-34.
- Spillane, J.P. 2005. Distributive leadership. *Educational Forum*, 69:143–157.
- Stogdill, R. 1948. Personal factors associated with leadership: a survey of literature. *Journal of Psychology*, 25:35-71.
- Stoll, L. 2004. *Leadership Learning: Designing a Connected Strategy*. Seminar Series No. 66. Melbourne, Victoria, IARTV.

- Stone, F.M. 2007. *Coaching and mentoring: how to choose the right technique to boost employee performance*. 2nd ed. Melbourne: Institute for Teaching and School leadership Limited.
- Strauss, A. & Corbin, J. 1991. *Basics of qualitative study: grounded theory, procedures and techniques*. Newbury Park, California: Sage.
- Stringer, E.T. 2004. *Action study in education*. Upper Saddle River, NJ: Pearson Education Inc.
- Strydom, H. 1998. *Ethical aspects of study in the caring professions*. In: A.S. de Vos, Pretoria: Van Schaik.pp. 23-26.
- Swanepoel, T.C. 1999. *Critical thinking in history. An educational psychological approach to instruction*. Unpublished D.Phil. at RAU, Johannesburg.
- Swanepoel, C &Booyesen, J. 2006. The involvement of teachers in school change: a comparison between the views of school principals in South Africa and nine other countries. *South African Journal of Education*, 26(2):189–198.
- Talbot, L.A. 1995. *Principles and practice of nursing study*. London: Mosby Inc.
- Tamkin, P., Hirsh, W. &Tyers, C. 2003. Chore to champions. The making of better people managers. *IES Report 389*. Brighton: Institute for Employment Studies.
- Tannenbaum, A.S. & Schmitt, W.H. 1958. How to choose a leadership pattern. *Harvard Business Review*, 36: 95-101
- The Constitution of the Republic of South Africa*. 1996. Pretoria: Government Press.
- Thomas, W. 2009. *Coaching for performance, creativity for learning*. www.creativityforlearning.co.uk/id5.html. [Accessed on 14 November 2011].

- Tse, H.H. M. & Dasborough, M.T. 2008. A Study of Exchange and Emotions in Team Member Relationships. *Group and Organization Management*, 33 (2): 194-215.
- Van Kessel, L. 2006. Coaching, a field for professional supervisors?' *Ljetopis Socijalnog Rada*, 14 (2): 387-430.
- Vroom, V.H., & Yetton, P.W. 1973. *Leadership and decision-making*. Pittsburgh: University of Pittsburgh Press.
- Vygotsky, L.S. 1978. *Mind in society: the development of higher psychological processes*. Cambridge, MA: Harvard University Press.
- Wadsworth, Y. 1997. *DIY social study*. Sydney: Allen & Unwin
- Wegge, J. 2003. *Führung von Arbeitsgruppen*. Göttingen: Hogrefe.
- Wekesa, G.W., 1993. The impacts of head teachers' instructional leadership on learner academic achievement in Kenya, *Unpublished Ph.D. Dissertation*, Teachers College, Columbia, Columbia University.
- Wenger, E. 1998. *Communities of Practice: Learning, Meaning, and Identity*. New York: Cambridge University Press.
- Whitmore, J. 2002. *Coaching for performance*. London: Nicholas Brealey Publishing.
- Wiersma, W. 2000. *Study Method in Education: An Introduction*. San Francisco: Library of Congress Cataloguing-In-Publication Data.
- Wimmer, R.D. & Dominick, J.R. 1997. *Mass Media Study: An Introduction*. Belmont, MA: Wadsworth.
- Yegidis, B.L. & Weinbach, R.W. 1996. *Research methods for social workers*. London: Allyn and Bacon.

York-Barr, J. & Duke, K. 2004. What do we know about teacher leadership? Findings from two decades of scholarship. *Review of Educational Study*, 74(3):255-316.

Zeus, P. & Skiffington, S. 2002. *The coaching at work toolkit: A complete guide to techniques and practices*. Sydney: McGraw-Hill

APPENDIX A
PERMISSION TO CONDUCT
RESEARCH BY DEPARTMENT
OF EDUCATION



kzn education

Department:
Education
KWAZULU-NATAL

Enquiries: Sibusiso Alwar

Tel: 033 341 8610

Ref.:2/4/8/196

Mr PK Triegaardt
46 Maple Road
Grays
Essex
UNITED KINGDOM

Dear Mr Triegaardt

PERMISSION TO CONDUCT RESEARCH IN THE KZN DoE INSTITUTIONS

Your application to conduct research entitled: **The Role of Distributive Leadership as Strategy to Ensure Effective Schools: a Comparative Case Study within Selected South African Schools**, in the KwaZulu-Natal Department of Education Institutions has been approved. The conditions of the approval are as follows:

1. The researcher will make all the arrangements concerning the research and interviews.
2. The researcher must ensure that Educator and learning programmes are not interrupted.
3. Interviews are not conducted during the time of writing examinations in schools.
4. Learners, Educators, Schools and Institutions are not identifiable in any way from the results of the research.
5. A copy of this letter is submitted to District Managers, Principals and Heads of Institutions where the intended research and interviews are to be conducted.
6. The period of investigation is limited to the period from 01 May 2012 to 31 December 2014.
7. Your research and interviews will be limited to the schools you have proposed and approved by the Head of Department. Please note that Principals, Educators, Departmental Officials and Learners are under no obligation to participate or assist you in your investigation.
8. Should you wish to extend the period of your survey at the school(s), please contact Mr. Alwar at the contact numbers below.
9. Upon completion of the research, a brief summary of the findings, recommendations or a full report / dissertation / thesis must be submitted to the research office of the Department. Please address it to The Director-Resources Planning, Private Bag X9137, Pietermaritzburg, 3200.
10. Please note that your research and interviews will be limited to the following schools and institutions:

- | | |
|------------------------|----------------------------|
| 1. AMAHOBE P | 11. FAITH CHRISTIAN |
| 2. AMAJUBA H | 12. FERRUM H |
| 3. BLUE MOUNTAIN P | 13. INGOGO P |
| 4. BOTHA'S PASS FARM P | 14. INTUKU P |
| 5. CHARLESTOWN H | 15. ISLAMIC COLLEGE N/C |
| 6. CLAVIS P | 16. KROMELLENBOOG P |
| 7. DRAKENSBERG P | 17. MAHLEKEHLATHINI P FARM |
| 8. EKUBONGENI P | 18. NKETHENI P |
| 9. EMTHUNZINI P | 19. PANORAMA C |
| 10. ENGODINI P | |

...dedicated to service and performance
beyond the call of duty.

KWAZULU-NATAL DEPARTMENT OF EDUCATION

POSTAL: Private Bag X9137, Pietermaritzburg, 3200, KwaZulu-Natal, Republic of South Africa

PHYSICAL: Office G.25, 185 Pietermaritz Street, Metropolitan Building, Pietermaritzburg 3201



kzn education

Department:
Education
KWAZULU-NATAL

- 20. PHOKWENI P
- 21. PRAISE PP
- 22. ROOIWAL P
- 23. SATHYA SAI SCH N/CASTLE
- 24. SINQOBILE P
- 25. SIYALUNGELWA S

- 26. SLANGRIVIER P
- 27. ST DOMINIC'S ACADEMY
- 28. GLENCALDER P
- 29. HERTZOG PARK P
- 30. HOPE C
- 31. HUTTENPARK

Nkosinathi S.P. Sishi, PhD
Head of Department: Education

...dedicated to service and performance
beyond the call of duty.

KWAZULU-NATAL DEPARTMENT OF EDUCATION

POSTAL: Private Bag X9137, Pietermaritzburg, 3200, KwaZulu-Natal, Republic of South Africa

PHYSICAL: Office G-25, 188 Pietermaritzburg Street, Metropolitan Building, Pietermaritzburg, 3201

APPENDIX B
ETHICAL CLEARNESS TO
CONDUCT RESEARCH



Prof RJ Botha
Department of Educational Leadership and Management
College of Education
PO Box 392
Unisa
0003

Tel: (012)997-0320 e-mail: botharj@unisa.ac.za

2011-05-02

TO WHOM IT MAY CONCERN

TITLE OF RESEARCH: THE ROLE OF DISTRIBUTIVE LEADERSHIP AS STRATEGY TO ENSURE EFFECTIVE SCHOOLS: - A COMPARATIVE CASE STUDY WITHIN SELECTED SOUTH AFRICAN SCHOOLS

RESEARCHER: P. K Triegaardt

SUPERVISOR: Prof R.J. Botha

The Committee for Academic Ethics of College of Education of the University of South Africa evaluated the research proposal and consent letters of the above research project and confirms that it complies with the approved Research Ethical Standards of the University of South Africa. Permission was granted for research to continue on 31st January 2011. The study supervisor and researcher demonstrated their intent to comply with the approved Ethical Standards during conduct of the research project.

Yours sincerely

A handwritten signature in black ink, appearing to read "RJ Botha", is written over a horizontal line.

Prof RJ (Nico) Botha

APPENDIX C
CONSENT TO PARTICIPATE IN
RESEARCH

PAUL TRIEGAARDT
46 MAPLE ROAD
GRAYS
ESSEX
UNITED KINGDOM
RM17 6LB

☎ +44 7761975462
☎ +44 1375 413192
p_triegaardt@hotmail.co.uk

21 February 2011

Dear Participant

CONSENT TO PARTICIPATE IN THE RESEARCH

I am a DED student at the University of South Africa. I am currently engaged in a research project entitled: The role of distributive leadership as strategy to ensure effective schools:- A comparative case study within selected South African schools. The research project is conducted under the supervision of Professor R J Botha from the College of Education.

The primary goal of the study is to determine the views of leaders on the distribution leadership approach as a leadership strategy: to define effective school leadership, leadership strategies and distributive leadership; to explore how distributive leadership support change and improve effective schools; to investigate how coaching can be used as an effective and successful distributed leadership strategy; to explore ways in which one design, implement and maintain coaching as a distributed leadership strategy to ensure effective school leadership in South Africa; and to explain how a distributive leadership model can be conceptualised as leadership strategy to ensure effective schools in South Africa.

I need to conduct confidential interviews to collect data on the distribution of leadership to ensure effective schools in South Africa. Each interview will last approximately 30 to 45 minutes and will be digital recorderd,

transcribed verbatim by the researcher and a qualified independent coder will verify the findings.

There are no risks involved in participation in the research study other than that there is a chance that you feel slightly uncomfortable with the topic addressed in the research. The immediate benefit of the study to you is that you will be able to verbalise your experiences on the distribution of leadership to ensure effective schools in South Africa.

The researcher will ensure your anonymity by omitting the use of your name on any of the data collection material; your name will be submitted with code numbers and a master list will be kept in a separate place under lock and key. Should confidentiality be threatened all records and links to identify will be destroyed. Furthermore, confidentiality will be ensured in that only the researcher and the independent coder will peruse the transcribed material.

Participation is strictly voluntary and you are under no obligation to take part in the study. You reserve the right to withdraw your consent at any stage during the research process. Such withdrawal will not result in penalty or loss of benefits to which you are otherwise entitled.

If you would like additional information concerning the study before or after it is complete, feel free to contact the researcher by phone or mail. The school will receive a hard copy of the completed thesis after completion of the study.

Thank you for your support.

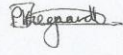

.....
P TRIEGAARDT

HED, FDE, BED (Hon), M ED (Cum Laude), D ED (Student)



.....
R J BOTHA: Professor and supervisor

BSc (UP), DEd (Unisa), SLC (Indiana Principals' Leadership Academy)

With my signature I voluntary consent to participate in the above -
mentioned research project and I give permission for this research project
to be digital recorded. I confirm that I have received a copy of the assent
form to keep.



.....
Signature



APPENDIX D

INTERVIEW SCHEDULE

The interview style used in this research consisted of a list of questions based on the role of distributed leadership to ensure effective schools in South Africa. The following questions were asked to the participants in this study:

Question 1: What do you understand by educational leadership? What purpose has educational leadership in your current job role?

Question 2: What form of leadership do you apply in your current job role? Why this type of leadership?

Question 3: What do you understand by distributed leadership?

Question 4: Many people agree that when teachers work together the learning of students is enhanced. Why do you think this is the case?

Question 5: If team work is improving the learning of students then it is worth exploring a little further do teachers influence the work of each other? How? When? Why?

Question 6: If you want to improve the quality of the work in your subject area, who would you go to? Why this person?

Question 7: What encourages the interaction between teachers? What is it, in your school that makes this interaction possible? Is there more that could be done? Suggestions?

Question 8: In what other ways to teachers lead beyond the classroom?

Question 9: What opportunities are there for you develop as a leader within your school?

Question 10: Do post holders play a special role leadership role?

Question 11: Do you see distributed leadership as the responsibilities or jobs of the principal and the deputy head teacher which they distribute to other people?

OR

Do you see school leadership as something in which each teacher has some responsibility from the start and that the principal or deputy head teacher coordinates in ways that make the sharing of leadership more important?

Question 12: Do you think that the distribution of leadership can enhance the development of the school?

Question 13: Do post holders meet with the principal or with the deputy on a regular basis to discuss the distribution of tasks? What type of tasks is distributed? Why this type of tasks?

Question 14: Lots of responses were given during this session. Do you think that in South Africa can use the distributed leadership approach to ensure effective schools in South Africa? Why?

APPENDIX E
TRANSCRIPTION AND TYPING
SERVICES

Transcription & Typing Services



Julia Martinelli
P.O. Box 7827
Centurion 0046
Cell: 083 227 5966
Fax: 086 647 6813
juliamb1@mweb.co.za

25 October 2012

To whom it may concern,

This letter serves as confirmation that my company, Transcription & Typing Services transcribed the digital recordings for Mr. Paul Triegaardt; and no charges were made between the transcribes and the actual recordings.

Sincerely,

Julia Martinelli
Transcription & Typing Services

APPENDIX F
NON PARTICIPATION –
DYSFUNCTIONAL SCHOOLS



Phumelela Ward Principals Forum

SEM: Mr P. R. B Bhagwandass

Chairperson: J.C. du Plooy
Drakensberg Primary School
034 3185011/0845118670

6 August 2012

Mr Paul Triegaardt
paultriegaardt@yahoo.co.uk

Sir

I herewith state that I, as chairperson of the Phumelela Education Ward, Principal's Forum (2007 – 2011), have informed and requested 26 Head Masters of schools ranging from deep rural areas to urban areas to participate in the OSCAR Research Model.

I have also presented them with the relevant literature I have received from you in this regard.

Unfortunately none of these schools were prepared to participate.

Yours faithfully

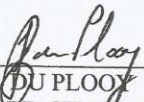

J.C. DU PLOOY
WARD CHAIRPERSON
(2007 – 2011)

APPENDIX G
TRAINING MANUAL

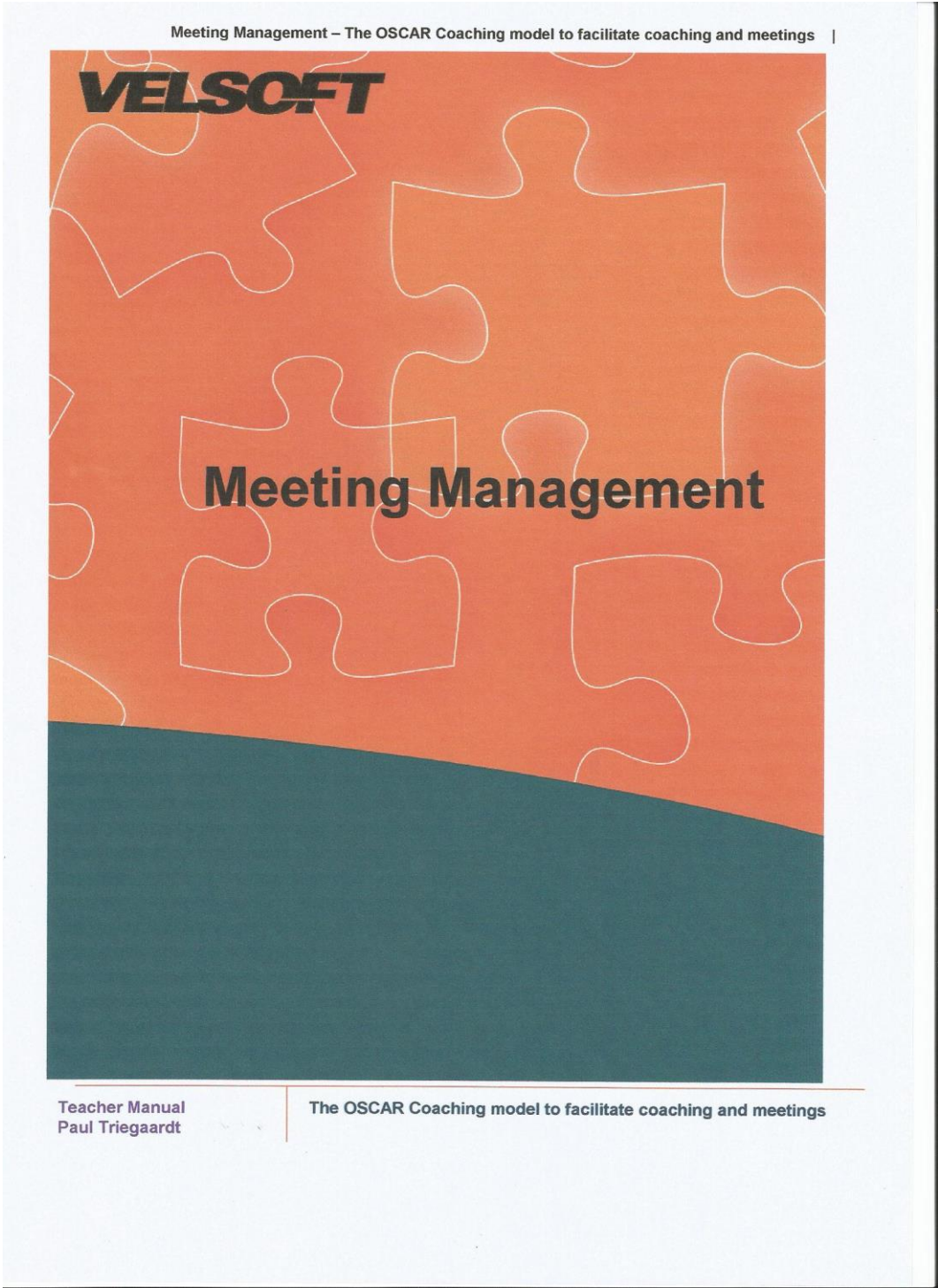

ACKNOWLEDGEMENTS

The researcher hereby wants to acknowledge:-

1. Andrew Gilbert from Worthing Consulting Ltd who gave permission that I may use the OSCAR coaching model to facilitate meetings in my research.
2. Velsoft Training Materials in Canada who sponsored the meeting management templates and materials for the development of the training manual.

Meeting Management – The OSCAR Coaching model to facilitate coaching and meetings |

Making a Meeting Work		OSCAR Meeting Planning Checklist															
<table border="1"> <thead> <tr> <th>Effective Meetings</th> <th>Ineffective Meetings</th> </tr> </thead> <tbody> <tr> <td>People are prepared</td> <td>Nobody prepared</td> </tr> <tr> <td>Meetings start & finish on time</td> <td>Meetings start late and end late</td> </tr> <tr> <td>Everyone gets to talk</td> <td>Certain people dominate the conversations</td> </tr> <tr> <td>Decisions are made by the group</td> <td>Certain people dominate decisions</td> </tr> <tr> <td>Actions get accomplished</td> <td>Nothing gets accomplished</td> </tr> <tr> <td>Someone takes notes or minutes</td> <td>No record of meetings so discussions occur over and over</td> </tr> <tr> <td>Agenda is prepared and available ahead of time</td> <td>No agenda</td> </tr> </tbody> </table>	Effective Meetings	Ineffective Meetings	People are prepared	Nobody prepared	Meetings start & finish on time	Meetings start late and end late	Everyone gets to talk	Certain people dominate the conversations	Decisions are made by the group	Certain people dominate decisions	Actions get accomplished	Nothing gets accomplished	Someone takes notes or minutes	No record of meetings so discussions occur over and over	Agenda is prepared and available ahead of time	No agenda	<p>Outcome</p> <ul style="list-style-type: none"> ✓ To review where we are versus where we want to be ✓ To learn from actions taken so far ✓ To make some decisions about the way forward ✓ To refine the action plan to implement our decisions <p>Situation</p> <ul style="list-style-type: none"> ✓ Welcome – expectations, agenda and outcomes ✓ What have we achieved from the previous meeting? ✓ What have we learned since the last meeting? ✓ What is the current situation? ✓ Where are we now versus where we want to be? <p>Options to choose from</p> <ul style="list-style-type: none"> ✓ What options do we have to consider moving forward? ✓ What are the consequences of our different options? ✓ Which options are the best? <p>Action planning</p> <ul style="list-style-type: none"> ✓ What shall we do first, second, third? ✓ Who will do what? ✓ When will they do it? <p>Meeting review</p> <ul style="list-style-type: none"> ✓ Did we achieve our achieve meeting outcomes? ✓ What can we do better next time?
Effective Meetings	Ineffective Meetings																
People are prepared	Nobody prepared																
Meetings start & finish on time	Meetings start late and end late																
Everyone gets to talk	Certain people dominate the conversations																
Decisions are made by the group	Certain people dominate decisions																
Actions get accomplished	Nothing gets accomplished																
Someone takes notes or minutes	No record of meetings so discussions occur over and over																
Agenda is prepared and available ahead of time	No agenda																
<p>When to Hold a Meeting</p> <p>Hold a meeting when:</p> <ul style="list-style-type: none"> • You want information/advice from your group. • You want to involve your group in solving a problem or making a decision. • There is an issue that needs to be clarified. • You have concerns that you want to share with your group. • There is a problem that involves people from different groups. • There is a problem to resolve or a decision to be made and it's not clear what the problem is or who is responsible for dealing with it. <p>Don't hold a meeting when:</p> <ul style="list-style-type: none"> • There is inadequate data/poor preparation. • Something could be communicated better by telephone, memo, or in a one-to-one discussion. • The subject is trivial. • The decision-maker has his or her mind made up. • The subject matter is so confidential or secret that it can't be shared with some group members. • Personnel issues like hiring, firing, and negotiating salaries need to be dealt with. • There is too much anger and hostility in the group. 	<p>Creating an Effective OSCAR Meeting</p> <p>O – Outcome</p> <p>All meetings are called for a reason – to achieve something. Every meeting should have a desired outcome. Therefore, in planning a meeting, the basic first step is to write down the outcome for the meeting and let the attendees know in advance what that outcome is. The second step is to let people know in advance what the process will be to achieve that outcome. You should always have a clear outcome, otherwise don't have a meeting. The result of a clear well-formed outcome will be that all the attendees turn up knowing what the meeting is attended to achieve. The clarity of the outcome and the process will keep people engaged.</p> <p>S – Situation</p> <p>When the outcome for the meeting is clear, the first item on the agenda will always be what is happening. The meeting will have been called in response of what is happening, the situation. The situation might be a problem that needs a solution, an opportunity that needs pursuing or agreement is needed on roles and responsibilities for a project. The content of a meeting is always unique and the process for a meeting can always be the same. OSCAR is such a process. During the situation part of the agenda people will be exchanging updated information and progress reports and actions that had been agreed in previous meetings. Without a clear outcome for the meeting, people can get bogged down in detail, get defensive about the lack of progress or even angry at the contribution of others. It is the focus that a clear outcome provides for a group that enables people to remind themselves as to the purpose of the meeting and stop getting stuck in the situation. A clear outcome and the clarity everyone gets from the discussion around the situation now provide momentum to move forward. Well-formed outcomes are desirable – problem situations are not. The next natural stage is to want to move to making some choices that would enable a move from the situation to the outcome.</p>																

Meeting Management – The OSCAR Coaching model to facilitate coaching and meetings |

Setting the Place

When you choose a location for your meeting, consider these factors.

- Availability of the room at the time of the meeting.
- Appropriate furniture including tables and chairs.
- Adequate lighting and ventilation.
- Free from interruptions and distractions.
- Convenience for participants.
- Cost.

Physical arrangements should also include these considerations.

- Water available for the participants.
- A flip chart, whiteboard, or overhead projector.
- Power connections if requested.

If meetings last more than an hour and a half, a break with refreshments should be scheduled.

C – Choices and consequences

Group decision making consists of brainstorming all the possible choices available, then deciding on the best choice. The best choice is the one with the highest likelihood of achieving the desired outcome. The process of brainstorming is highly creative. It is the main reason you wanted people to meet – otherwise you could have made the decisions on your own. Decision making involves making the best selection from a list of choices. The process involves evaluating the pros and cons of each choice (the consequences). The group coach has the task of ensuring the group is creative and sticks to the process that will lead to productive decision making.

A – Actions

A clear sign of a wasted meeting is for everyone to leave without any clear action planning agreed. A well-formed outcome, a clear situation and a creative decision making process, with full involvement from all people in the group, will lead to committed action planning. Groups with this kind of clarity will want to take actions. The logical process that has been followed so far will result in people wanting to take responsibility and be recognized as having contributed to the future success of the group. Action planning consists of answering three questions:-

- What actions shall we take?
- Who will take each action?
- When will each of the actions be taken?

A clear action plan with agreed responsibilities and time frames is the sign of a productive meeting. However, the only real measure of success is if the actions actually get taken and lead to the desired outcome. For us to notice this success we will need to monitor progress and review.

R – Review

The meeting will end with a review. Did the outcome for the meeting get achieved? If it did then the group can agree that the process was successful and should be followed again. If it wasn't achieved, the group can decide on how the process can be improved and used for subsequent meetings. This evaluation of the success of the meeting is very difficult if no outcome was ever present. Many meetings are held purely to review how the action plan is going. Such review meetings follow OSCAR. OSCAR is the repeatable meeting process that once learned never changes. Using OSCAR to coach groups is essentially the same skill required to run effective meetings. Understanding the OSCAR process you can now plan for any meeting.

Meeting Management – The OSCAR Coaching model to facilitate coaching and meetings |

Agenda Checklist

- ✓ Name of Group/Activity
- ✓ Date and time
- ✓ Place
- ✓ List of Attendees
- ✓ Attendance
- ✓ Minutes from previous meeting
- ✓ Committee Reports
- ✓ Unfinished Business
- ✓ New Business
- ✓ Date of next meeting
- ✓ Time of next meeting
- ✓ Adjournment

Leadership Skills

Encouraging

Group members may drop out of participating in the discussion. However, the silent member may have a valuable contribution to make. One very effective way to bring out that contribution is to pay special attention to the member for past performance or contributions.

Expressing Group Feelings

In some group problem-solving activities, members may fear blame and assume a noncommittal attitude that turns into an awkward silence. This is a critical point for the leader. Rather than have each member in turn express his or her individual ideas, the leader may express his or her sense of what the group is feeling.

Example: "We've come up with some good ideas for solving this turnover problem, but I don't think we've gotten all possible solutions on the table yet. It seems that people are nervous about expressing unconventional ideas. Remember that this is just a brainstorming suggestion, so we're not going to evaluate or judge ideas just yet – we just want to get them on the table."

Make sure that all ideas are valued.

Create a climate where people feel comfortable expressing differences of opinion. If members tend to agree, appoint a devil's advocate to bring out opposing points to view.

Harmonizing

Conflict between members may be legitimate, but it can destroy the effective functioning of the group. If the leader can mobilize the group to help two opponents explore their differences, they can then become more objective about the differences, and the emotional tension which has been built up will be drained off.

Gate-Keeping

One important role of a leader is to keep the channels of communication open. Criticisms should not be stifled, as they are often valid and stimulating. However, if criticisms become destructive, it is better to let the group itself work out the conflict openly, rather than sidestep it.

Modifying

When the leader's own ideas are attacked, the natural response is to react by defending that position or enforcing ideas with positional power. However, that reaction is usually counterproductive.

Evaluating

At some point in the meeting, members may want to finish before the objective is achieved. If and when this happens, the best way to deal with it is to focus on the objective and keep the meeting going.

Leading a Meeting

In order to accomplish a task, you as leader must follow these steps:

Initiating

There are many critical points during a meeting when the leader's action can make or break the success of the meeting. One of these points comes at the beginning. In most situations, it is preferable to begin the meeting with a clear-cut definition of the problem.

Information or Opinion-Seeking

After the problem has been clearly defined and feelings about the problem clarified, your group may expect you, as the leader, to provide your solution to the problem. However, at this point it is much more useful for you as leader to solicit more information and ideas from others. It is unlikely that you will have all the information necessary for a sound decision. Even if you feel that you can make one, a premature decision may stifle the group's feeling of participation. This will undoubtedly lead to a lack of commitment in the implementation stage.

Information or Opinion-Giving

When the group asks for more information or the leader's opinion, you should give it to them. However, in doing this, you should stick to the objective facts as you see them and avoid taking sides.

Clarifying

As the meeting progresses, the leader must continually monitor the flow of information to ensure understanding. In exploring possible causes of the problem, a lot of ideas will surface. In such a situation, the tendency is for the group to prescribe a cure before the real cause is actually determined. This is a good time for the leader to step in and review the alternatives, so that the group can begin to see more clearly the issues before them.

Summarizing

Hidden agendas can block the progress of any problem-solving meeting. An effective leader will work to uncover these roadblocks and get them out in the open. Once they are in the open, the leader should take steps to remove the roadblocks and move the group toward the desired objectives. This can be done by summarizing what has happened so far, sticking to the objective facts that have been developed, and avoiding any personal issues.

Consensus Testing

Before making the final decision, the leader should ensure that group members have sufficient commitment to implement the decision. To do this, you must check out your impressions with the group to see if there is true consensus. You need to know how the group members actually feel about the decision: whether or not they are ready to commit themselves to carry it out successfully and accept the results, providing they are clear-cut. In other words, consensus is necessary; otherwise, the plan will fail.

The impact on well managed meetings using OSCAR

- Saved time.
- Improved motivation.
- Better decision making.
- Quicker problem solving.
- Building stronger and more productive working relationships.

Group coaching using the OSCAR coaching model

Meetings that involve all the team and encourage participation and responsibility are more constructive than meetings in which the leader tells, instructs and makes all the decisions. Any meeting which involves discussion, problem solving, and action planning, is an opportunity for group coaching.

Group coaching involves:-

- ✓ Providing leadership without taking the reins.
- ✓ Focusing on asking questions instead of telling.
- ✓ Listening and building consensus

Example of generic agenda using the OSCAR process for a one hour meeting

Reminder to facilitator of meeting or group coach

Remember, the content is unique – the process always remains the same. As a group coach you are the master of the process.

O	<p>Meeting outcomes:</p> <ul style="list-style-type: none"> To review where we are versus where we want to be. To learn from actions taken so far. To make some decisions about the way forward. To refine the action plan to implement our decisions. <p>Welcome</p> <ul style="list-style-type: none"> Expectations, agenda and outcomes 	5 mins
S	<p>Progress so far:</p> <ul style="list-style-type: none"> What have we achieved since our last meeting? What have we learned since our last meeting? What is the current situation? Where are we now versus where we want to be? 	15 mins
C	<p>Options to choose from:</p> <ul style="list-style-type: none"> What options do we have to consider moving forward? What are the consequences of our different options? Which options are best? 	20 mins
A	<p>Action planning:</p> <ul style="list-style-type: none"> What shall we do first, second, third? Who will do what? When will they do it? 	15 mins
R	<p>Meeting review:</p> <ul style="list-style-type: none"> Did we achieve our meeting outcomes? What can we do better next time? 	5 mins

Activity for facilitator of next meeting

Think about a forthcoming meeting (senior team meeting, phase meeting, subject meeting, committee meeting etc.)

The meeting outcomes (what is the purpose of the meeting?)

The agenda items and the time allocated to each item.

How will use "group coaching" to maximise the effectiveness of your meeting?

What actions would you expect to come out of the meeting?

How will you close the meeting?

Facilitation of a meeting

Managers are often asked to “facilitate” rather than “instruct” or “manage” meetings, training sessions, and other small groups. Sometimes it is difficult to make that transition from “instructor” to “facilitator.” The facilitator’s role is to support people to do their best thinking. To do this, a facilitator must:

- Encourage full participation
- Promote mutual understanding
- Enable group members to search for inclusive solutions
- Teach new thinking skills

At the same time they are helping groups cultivate shared responsibilities and build sustainable agreements.

Most groups don’t know how to solve tough problems on their own. They don’t know how to build a shared framework of understanding. Without realizing it, most people edit their thinking before they speak. Who wants his/her ideas criticized before they are fully formed? Who wants to make an effort to express a complex idea if others are whispering, doodling, or watching the clock? They dread conflict and discomfort and they try hard to avoid it. They need a facilitator!

However, anyone in a group can use facilitative behaviors, whether or not they are a facilitator.

Can you identify the difference between chairing a meeting and facilitating a meeting?

APPENDIX H

**FEEDBACK ON OSCAR
COACHING MODEL TO
FACILITATE MEETINGS**



Primêre Skool

Drakensberg

Privaatsak 6646
Newcastle 2940
Tel: 034 318 5011/2
Fax: 034 318 3723
e-poc: draklee@crazyweb.co.za
www.draklee.com

To: Paul Triegaardt
46 Maple Road
Grays
Essex
United Kingdom
RM 17 6LB
paulriegardt@yahoo.co.uk

From: J.C. du Plooy
Headmaster
Drakensberg Primary School

Sir

SUMMARY OF PARTICIPATION IN RESEARCH PROJECT

It gives me pleasure to report on my experience and involvement in your research model.

The OSCAR School Management Model gives confidence to school leaders to distribute the responsibility and accountability of the academic-, curricular, co-curricular and extra-curricular management in an educational institution.

Coaching and mentoring, firstly members of management and secondly the whole educator staff component, leads to a common vision and mission directive of the route and direction to be embarked upon. This stems as a result of collective decision making which is nurtured and promoted through the application of the OSCAR Distributive Leadership Model.

This Model enhances and also simplifies management procedure in that it promotes collaboration amongst all stakeholders based on a position of trust in managers. The "recipe" is conclusive to formal implementation in a more relaxed atmosphere.

One of the major benefits of the model is that once you are familiar

" 'n Gesogte skool met die kind as kern "

with the steps and order of operational implementation, time is used more effectively and efficiently to reach implementable project management guidelines.

It is enabling in that the planning of management, the organization of people and processes involved, as well as the activation of projects, duties, etc. culminates in clear control and quality monitoring for managers. The reinventive nature of the OSCAR model causes it to sustain momentum in management procedure until finalization of specific tasks or projects.

I am convinced that this model is implementable at all levels of education management and will empower and capacitate educational leaders and educators to deliver well organized institutionalised education.

Yours Faithfully

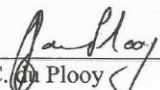

J.C. de Plooy
Headmaster

24 July 2012



PRIMÊRESKOOI
HUTTENPARK
PRIMARY SCHOOL

Tel: (034) 312 1242 Fax: (034) 315 3791 e-mail: huttenps@saschools.co.za
Private Bag/Privaatsak 6624 Newcastle 2949

14 February 2013

Hallo Paul

Thank you for forwarding the OSCAR - Training Manual. I studied the contents and was very impressed with the easy explainable format of conducting meetings.

One often has meetings which is poorly organised and which leads to frustration. Often meetings go of the rails and one never accomplish your outcomes or even get to a plan to solve problems. If one follows these "OSCAR" steps in planning a meeting, setting up an agenda and controlling one, you realise how much time one can save, if you control it in a productive way. Not even mentioning the easy way of constructing your minutes around the OSCAR example of an agenda.

I do feel that this model will be effective in stimulating and further teaching and learning, especially in subject meetings or grade meetings which often seems as a "let's do it and get over it - meeting". One can use this model to be better organised, Concerns, problems or issues can be solved in a very constructive way. Especially setting outcomes we would like to achieve, creating choices and actions to meet certain time frames. Often one discusses problems but neglect to keep to a time frame of how and when the plans must be achieved.

Creating a simple time frame for the different areas, helps in leading and facilitating the group to keep to the times, makes the running of the meeting smoother, cutting out the "chit chatting", which often leads to unproductive meetings. The group participants will be motivated, knowing what will be discussed and how long the duration of the meeting will be.

The OSCAR model gives people the opportunity to develop. It gives the team leader or manager the opportunity to coach (facilitate) other team members. Team members have the opportunity to give their opinion and to come up with ideas, especially the quite ones, as well. Often we see that one person can send a meeting into a one way direction, especially if managers don't encourage full participation or giving other a chance to be creative in thinking, trying to solve problems.

The OSCAR agenda makes provision for the monitoring of future action plans from the options one chooses. Setting time frames for each plan, when it must be done and who is responsible, makes a manager or leader administrative task easier. She/he can follow up with other team members and see where the process is going. This will already help with the next meeting because members will know that they will have to report back on time frames set out. The facilitator setting up the agenda for the next meeting will start with our previous goals or plans, which will reflect on our prior outcomes and how we can go forward from there. It is basically a short reflection on our previous meeting, to see what worked and what not. Setting our way of thinking for this meeting and being creative. By handing the agenda before the meeting to the team, it can prepare them to start thinking, which can lead to a more productive meeting, saving time.

I like the idea that the OSCAR example - make provision for a one hour meeting. I believe that one must always try to keep meetings short and simple, to the point. Team members often get discouraged with long meetings and don't come with a positive attitude to these meetings. With the OSCAR model I can see that meetings will be productive, members will be eager, they know what to expect, because it is organised.

Thank you for your research and creating this model. I believe it will make meetings 'enjoyable'.

Good luck with your features endeavours.

Greetings
Johan Delpont
Huttenpark Primary School