

TABLE OF CONTENTS

DEDICATION	I
ABSTRACT	II
KEY TERMS	IV
DECLARATION	V
ACKNOWLEDGEMENTS	VI
TABLE OF CONTENTS	VIII
LIST OF ABBREVIATIONS	XII
LIST OF TABLES	XIII
LIST OF FIGURES	XIV
LIST OF APPENDICES	XV
CHAPTER 1	1
ORIENTATION OF THE STUDY	1
1.1. BACKGROUND OF THE STUDY	1
1.2. CONTEXT AND PROBLEM OF THE STUDY	4
1.3. RATIONALE OF THE STUDY.....	7
1.4. AIM OF THE STUDY.....	9
1.5. RESEARCH QUESTIONS	10
1.6. LIMITATIONS OF THE STUDY	11
1.7. CONCLUSION	12
CHAPTER 2	13
THEORETICAL FRAMEWORK AND LITERATURE REVIEW	13
2.1 INTRODUCTION	13
2.2 TPCK THEORETICAL FRAMEWORK.....	13
2.2.1 <i>Technology Knowledge (TK)</i> :.....	15
2.2.2 <i>Content Knowledge (CK)</i> :	16
2.2.3 <i>Pedagogical Knowledge (PK)</i> :	16
2.2.4 <i>Pedagogical Content Knowledge (PCK)</i> :.....	17
2.2.5 <i>Technological Content Knowledge (TCK)</i> :	18
2.2.6 <i>Technological Pedagogical Knowledge (TPK)</i> :	18
2.2.7 <i>Technological Pedagogical Content Knowledge (TPCK)</i> :.....	19
2.3 A FEW EPISTEMOLOGICAL ISSUES/ CURRENT CHALLENGES FOR THE TPCK FRAMEWORK	22
2.3.1 <i>Technological Knowledge (TK)</i> :	24
2.3.2 <i>Pedagogical Knowledge (PK)</i> :.....	24
2.3.3 <i>Content Knowledge (CK)</i> :	24
2.3.4 <i>Technological Content Knowledge (TCK)</i> :	24
2.3.5 <i>Technological Pedagogical Knowledge (TPK)</i> :	25
2.3.6 <i>Pedagogical Content Knowledge (PCK)</i> :.....	25
2.3.7 <i>Technological Pedagogical Content Knowledge (TPCK)</i> :.....	25
2.4 HYPOTHETICAL RELATIONSHIP BETWEEN TPCK, ITS CONSTRUCTS AND LEARNERS' ACHIEVEMENT ...	26
2.5 LEARNER ACHIEVEMENT.....	28
2.5.1 <i>Learner achievement and teacher factors</i>	29

2.5.1.1	<i>Teacher factor in terms of learner achievement</i>	29
2.5.1.2	<i>Teacher factor related to qualifications</i>	29
2.5.1.3	<i>Teacher factor related to assessment</i>	30
2.5.1.4	<i>Teacher factor related to teaching</i>	30
2.5.1.5	<i>Teacher factor related to teacher beliefs</i>	31
2.5.1.6	<i>Teacher factor related to teacher teaching experience</i>	31
2.5.2	<i>Learner achievement in electricity</i>	32
2.5.3	<i>Electricity as a high school physics topic</i>	36
2.6	TPCK IN THE TEACHING CONTEXT.....	38
2.6.1	<i>Assessing teachers' TPCK</i>	39
2.7	SUMMARY OF CHAPTER.....	40
CHAPTER 3.....		42
RESEARCH DESIGN AND METHODS.....		42
3.1	INTRODUCTION.....	42
3.2	RESEARCH DESIGN.....	42
3.3	RESEARCH METHODS.....	43
3.3.1	<i>Sample and participants in the study</i>	43
3.3.2	<i>Instruments</i>	44
3.3.3	<i>Description and the development of the instruments</i>	45
3.3.3.1	Physic Teachers' Technological and Pedagogical Content Knowledge Questionnaire (PTTPCKQ) 45	
3.3.3.2	Teachers' Electricity Teaching Lesson Plans (TETLP)	47
3.3.3.3	Learners' Confirmation of Physic Teachers' Technological and Pedagogical Content Knowledge Questionnaire (LCPTTPCKQ)	47
3.3.3.4	Learner Electricity Learning Confirmatory Questionnaire (LELCQ)	50
3.3.3.5	Learner Electricity Achievement Test. (LEAT)	51
3.4	METHODOLOGICAL NORMS (VALIDITY AND RELIABILITY ISSUES).....	52
3.4.1	<i>Validity of the instruments</i>	52
3.4.1.1	Validity of the Learner Electricity Achievement Test (LEAT)	52
3.4.1.2	Validity of the Physics Teachers' Technological and Pedagogical Content Knowledge Questionnaire (PTTPCKQ)	54
3.4.1.3	Validity of the Learners' Confirmation of Physic Teachers' Technological and Pedagogical Content Knowledge Questionnaire (LCPTTPCKQ)	55
3.4.1.4	Validity of the Learner Electricity Learning Confirmatory Questionnaire (LELCQ)	55
3.4.2	<i>Reliability of instruments</i>	56
3.4.2.1	Reliability of the Learner Electricity Achievement Test (LEAT)	56
3.4.2.2	Reliability of the PTTPCKQ, LCPTTPCKQ and LELCQ	57
3.5	RESEARCH PROCEDURES.....	57
	59
3.6	DATA ANALYSIS.....	59
3.6.1	QUANTITATIVE DATA ANALYSIS.....	59
3.6.2	QUALITATIVE DATA ANALYSIS.....	60
3.7	ETHICAL CONSIDERATIONS.....	61
3.8	SUMMARY OF CHAPTER.....	63
CHAPTER 4.....		64
RESULTS.....		64
4.1	INTRODUCTION.....	64
4.2	QUANTITATIVE DATA ANALYSIS.....	65

4.2.1	<i>Descriptive statistical analysis of physics teachers' demographic data</i>	65
4.2.2	<i>Correlation Analysis</i>	68
4.2.2.1	Correlation between Physics Teachers Technological and Pedagogical Content Knowledge, experience, qualifications and their learners' achievement	69
4.2.2.2	Correlation between physics Teachers' Technological Pedagogical Content Knowledge and physics teachers' gender	70
4.2.2.3	Correlation between physics teachers' Technological Pedagogical Content Knowledge and physics teachers' age	72
4.2.2.4	Correlation between physics teachers' TK, CK, PK, TCK, PCK, TPK and physics teachers' TPCK from the teachers' responses on the PTTPCCKQ Questionnaire.	74
4.2.2.5	Correlation between physics teachers' TK, CK, PK, TCK, PCK, TPK and physics teachers' TPCK from the learners' responses on the LCPTPCCKQ Questionnaire	76
4.2.3	<i>t-Test</i>	78
4.2.3.1	t-Test comparison of the PTTPCCKQ responses and the LCPTPCCKQ responses on TK	79
4.2.3.2	t-Test comparison of the PTTPCCKQ responses and the LCPTPCCKQ responses on CK	80
4.2.3.3	t-Test comparison of the PTTPCCKQ responses and the LCPTPCCKQ responses on PK	81
4.2.3.4	t-Test comparison of the PTTPCCKQ responses and the LCPTPCCKQ responses on PCK	82
4.2.3.5	t-Test comparison of the PTTPCCKQ responses and the LCPTPCCKQ responses on TCK	83
4.2.3.6	t-Test comparison of the PTTPCCKQ responses and the LCPTPCCKQ responses on TPK	84
4.2.3.7	t-Test comparison of the PTTPCCKQ responses and the LCPTPCCKQ responses on TPCK.	85
4.2.3.8	Summary of results of the t-Test comparison of the PTTPCCKQ responses and the LCPTPCCKQ responses of the 17 common questions	86
4.2.4	<i>Qualitative data analysis</i>	87
4.2.4.1	<i>Analysis of the Teacher Electricity Teaching Lesson Plans</i>	87
4.2.4.2	Sections of electricity in the CAPS physics syllabus which were reported by learners that their teachers were neglecting to teach	97
4.3	ANSWERING THE RESEARCH QUESTIONS.	104
4.3.1	<i>Research question one</i>	104
4.3.2	<i>Research question two</i>	105
4.3.3	<i>Research question three</i>	106
4.3.4	<i>Research question four</i>	107
4.3.5	<i>Research question five</i>	108
4.3.6	<i>Research question six</i>	109
4.3.7	<i>Research question seven</i>	110
4.4	SUMMARY OF CHAPTER	111
CHAPTER 5		112
DISCUSSION OF FINDINGS		112
5.1	INTRODUCTION	112
5.2	DISCUSSION OF THE FINDINGS	112
5.2.1	<i>Research question one</i>	112
5.2.2	<i>Research question two</i>	114
5.2.3	<i>Research question three</i>	115
5.2.4	<i>Research question four</i>	116
5.2.5	<i>Research question five</i>	118
5.2.6	<i>Research question six</i>	119
5.2.6	<i>Research question seven</i>	120
5.3	SUMMARY OF FINDINGS	122
CHAPTER 6		124
CONCLUSIONS AND RECOMMENDATIONS		124

6.1	INTRODUCTION	124
6.2	OVERVIEW	124
6.3	CONCLUSION	125
6.4	RECOMMENDATIONS.....	127
6.5	RECOMMENDATIONS FOR FUTURE RESEARCH	128
REFERENCES.....		132
APPENDICES.....		145

LIST OF ABBREVIATIONS

CAPS	-	Curriculum and Assessment Policy Statement
CK	-	Content Knowledge
DoE	-	Department of Education
DoBE	-	Department of Basic Education
GPA	-	Grade Point Average
ICT	-	Information and Communication Technology
LCPTTPCKQ	-	Learners' Confirmation of Physics Teachers' Technological and Pedagogical Content Knowledge Questionnaire
LEAT	-	Learner Electricity Achievement Test
PCK	-	Pedagogical Content Knowledge
PK	-	Pedagogical Knowledge
PhET	-	Physics Education Technology
PTIM	-	Pedagogical Technological Integrated Medium
PTTPCKQ	-	Physic Teachers' Technological and Pedagogical Content Knowledge Questionnaire
SPSS	-	Statistical Package for the Social Science
TCK	-	Technological Content Knowledge
TETLP	-	Teachers Electricity Teaching Lesson Plans
TPACK	-	Technological Pedagogical Content Knowledge
TK	-	Technological Knowledge
TPCK	-	Technological Pedagogical Content Knowledge
TPK	-	Technological Pedagogical Knowledge
MST	-	Mathematics, Science and Technology

LIST OF TABLES

TABLE 1.1: COMPARISON OF NCS CANDIDATES' PERFORMANCE BY SELECTED SUBJECTS, 2012 TO 2016	5
TABLE 1.2: COMPARISON OF CANDIDATES' PERFORMANCE AT 30% AND ABOVE IN PHYSICAL SCIENCE BY PROVINCE, 2013 TO 2016 .	6
TABLE 3.1: NATIONAL SENIOR CERTIFICATE (NCS) DISTRICT PERFORMANCE, 2012 TO 2016	43
TABLE 3.2: STATEMENTS ON THE PTTPCQK ALONGSIDE ITS MODIFIED VERSION ON THE	49
LCPTTPCKQ	49
TABLE 3.3: A SUMMARY OF DATA ANALYSIS SHOWING THE INSTRUMENTS USED IN THE STUDY	61
TABLE 4. 1: TEACHERS' DEMOGRAPHIC DATA (N = 42)	67
TABLE 4. 2: SPEARMAN CORRELATION BETWEEN PHYSICS TEACHERS' TPCK, EXPERIENCE,	69
QUALIFICATIONS AND AVERAGE LEARNER MARK/ ACHIEVEMENT.....	69
TABLE 4.3: THE CROSS-TABULATION TABLE OF PHYSICS TEACHERS' GENDER COMBINED WITH TEACHERS' TPCK	71
TABLE 4.4: CHI-SQUARE TESTS OF PHYSICS TEACHERS' GENDER COMBINED WITH TEACHERS' TPCK.....	72
TABLE 4.5: THE CROSS TABULATION OF PHYSICS TEACHERS' AGE COMBINED WITH TEACHERS' TPCK	73
TABLE 4.6: CHI-SQUARE TESTS OF PHYSICS TEACHERS' AGE COMBINED WITH TEACHERS' TPCK.....	74
TABLE 4.7: SPEARMAN CORRELATION BETWEEN PHYSICS TEACHERS' TK, TPK, TCK, PK, PCK, CK AND	75
TPCK FROM THE TEACHERS' RESPONSES ON THE PTTPCQK QUESTIONNAIRE	75
TABLE 4.8: SPEARMAN CORRELATION BETWEEN PHYSICS TEACHERS' TK, TPK, TCK, PK, PCK, CK AND	77
TPCK FROM THE LEARNERS' RESPONSES ON THE LCTTPCKQ QUESTIONNAIRE	77
TABLE 4.9: SPSS OUTPUT OF THE INDEPENDENT SAMPLES T-TEST OF THE PTTPCQK RESPONSES AND THE LCPTTPCKQ RESPONSES ON TK	80
TABLE 4.10: TABLE 4.10: SPSS OUTPUT OF THE INDEPENDENT SAMPLES T-TEST OF THE PTTPCQK RESPONSES AND THE LCPTTPCKQ RESPONSES ON CK	81
TABLE 4.11: TABLE 4.11: SPSS OUTPUT OF THE INDEPENDENT SAMPLES T-TEST OF THE PTTPCQK RESPONSES AND THE LCPTTPCKQ RESPONSES ON PK	82
TABLE 4.12: SPSS OUTPUT OF THE INDEPENDENT SAMPLES T-TEST OF THE PTTPCQK RESPONSES AND THE LCPTTPCKQ RESPONSES ON PCK	83
TABLE 4.13: SPSS OUTPUT OF THE INDEPENDENT SAMPLES T-TEST OF THE PTTPCQK RESPONSES AND THE LCPTTPCKQ RESPONSES ON TCK	84
TABLE 4.14: SPSS OUTPUT OF THE INDEPENDENT SAMPLES T-TEST OF THE PTTPCQK RESPONSES AND THE LCPTTPCKQ RESPONSES ON TPK	85
TABLE 4.15: SPSS OUTPUT OF THE INDEPENDENT SAMPLES T-TEST OF THE PTTPCQK RESPONSES AND THE LCPTTPCKQ RESPONSES ON TPCK	86
TABLE 4.16: SUMMARY OF RESULTS OF THE T-TEST COMPARISON OF THE PTTPCQK RESPONSES AND THE LCPTTPCKQ RESPONSES OF THE COMMON QUESTIONS	86
TABLE 4.17: PHYSICS TEACHERS WITH TPCK AND THE TECHNOLOGIES THEY USE IN THEIR CLASSROOMS (N=31).....	93
TABLE 4.18: RESPONSES ON THE NUMBER OF LEARNERS WHO RESPONDED 'NO' PER EACH SECTION OF ELECTRICITY THEY WERE EXPECTED TO BE TAUGHT ON LELCQ QUESTIONNAIRE.....	99
TABLE 4.18: CONTINUED	100
TABLE 4.19: NUMBER AND PERCENTAGE OF LEARNERS WHO PASSED QUESTION ITEMS ON THE	103
LEAT TEST	103
TABLE 6:0:1 DISTRIBUTION OF THE PHYSICAL SCIENCE TEACHERS BY GENDER IN THE FOUR CIRCUITS OF THE NKANGALA EDUCATIONAL REGION (SOURCE: NKANGALA REGIONAL EDUCATION OFFICE).....	130

LIST OF FIGURES

FIGURE 1: TPCK FRAMEWORK ACCORDING TO KOEHLER AND MISHRA, 2009.....	14
FIGURE 2: A HYPOTHETICAL MODEL OF THE INTERRELATIONSHIPS AMONG TPCK CONSTRUCTS AND LEARNERS' ACHIEVEMENT.	27
FIGURE 3: RESEARCH PROCEDURE.....	59
FIGURE 4: COMPARISON OF THE TEACHERS' RESPONSES ON THE PTTCKQ AND THE LEARNERS' RESPONSES ON THE LCPTTPCKQ OF THE CONSTRUCTS OF THE TPCK FRAMEWORK SHOWING THE CORRELATIONS BETWEEN THE TPCK WITH ITS CONSTRUCTS (SEE SECTION 4.2.2.4 AND 4.2.2.5).....	65
FIGURE 5: THE RELATIONSHIP BETWEEN THE TEACHERS' RESPONSES TO THE PTTCKQ ON THE SIX	75
FIGURE 6: THE CORRELATION BETWEEN THE LEARNERS' RESPONSES ON THE LEARNERS' LCTTPCKQ ON THE	77
FIGURE 7: COMPARISON OF THE TEACHERS' RESPONSES ON THE PTTCKQ AND THE LEARNERS'	79
FIGURE 8: PERCENTAGE OF TEACHERS WITH TPCK AND NO TPCK.....	88
FIGURE 9: PERCENTAGE OF NATURE OF LESSON PLANS PROVIDED BY THE TEACHERS	90
FIGURE 10: PERCENTAGE OF TELEPHONIC REPOSES (FOLLOW UP) FROM THE TEACHERS.....	94
FIGURE 11: PERCENTAGES OF LEARNERS WHO RESPONDED 'NO' PER EACH SECTION OF ELECTRICITY	98

LIST OF APPENDICES

1.	Physic Teachers' Technological and Pedagogical Content Knowledge Questionnaire (PTTPCKQ)	131
2.	Learners' Confirmation of Physics Teachers' Technological and Pedagogical Content Knowledge Questionnaire (LCPTTPCKQ)	136
3.	Learner Electricity Learning Confirmatory Questionnaire (LELCQ)	139
4.	Learner Electricity Achievement Test (LEAT)	140
5.	Cognitive level complexity of the LEAT according the CAPS document	145
6.	Grade 12 Pilot Sample	147
7.	Case Processing Summary & Reliability Statistics	148
8.	Reliability of the PTTPCKQ, LCPTTPCKQ and LELCQ	149
9.	Permission to conduct research project (Ethical approval)	150
10.	Approval to conduct research from Department of Education	151
11.	Letter to the Principal	141
12.	Letter to the Educator	153
13.	Letter to the Parent	155
14.	Consent form for learner participants in the study	157
15.	Lesson Plan without technology	159
16.	Lesson Plan without technology from the Gauteng Department of Education	160
17.	Lesson Plan from Doc Scientia	168
18.	Editorial Certificate	183
19.	Similarity report	184

CHAPTER 1

ORIENTATION OF THE STUDY

1.1. Background of the study

The twenty first century classroom is no longer a place for the traditional teaching approach where the teacher is the only provider of knowledge. Today's teachers need to incorporate technology in their teaching to be effective and be able to motivate learners. Technology is playing a more progressive role with interactive and more learner centered classroom activities which interests learners more as well helping them to learn better. Alhababi, (2017) found that technology is an effective tool for both teachers and learners to enhance teaching and learning using TPCK if it is implemented properly. Khine, Ali, and Afari (2016) also found positive correlation between trainee teachers' technology knowledge and their achievements in a study conducted in the UAE.

Learner achievement in physical Sciences in South African schools lags behind the other major subjects yearly in the South African National Senior Certificate examinations (NSC). There are several teacher factors that may be responsible for low learner achievement. Some of these teacher factors are teachers' qualifications, assessment methods, teaching, beliefs and teaching experience (Berger, Giradet, Vaudroz and Crahay 2018).

A new factor, which is being researched in recent times is the Technological Pedagogical Content Knowledge (TPCK) of teachers. There is a number of researches around in-service teachers TPCK, and its contribution to their own achievement. However, research in serving

teachers TPCK in relation their learners' achievement is lacking. Hence it is the intention of this study to investigate if Physics Teachers TPCK or the lack of their TPCK may be one of the factors responsible for the low learner achievements in physical sciences.

Teachers with technological knowledge should be able to take advantage of technologies such as the Internet or make use of YouTube videos and computer simulations to mention a few technologies to enhance their own competences, thereby possibly improving learners' interests and achievements in physical sciences.

The Organization for Economic Cooperation and Development [OECD], which is an international organisation promoting policies that will improve the economic and social well-being of people around the world in well over 70 countries, reported that "science and mathematics performances do not augur well for South Africa's urgent requirements for skilled personnel in engineering, science and technology" (OECD, 2008 p.204). The OECD report posits that the problem is further exacerbated by the fact that fewer learners opt for mathematics and the physical sciences up until the matriculation examinations (OECD, 2008 p.204). For this reason, their access to high-skill areas, such as the sciences and engineering programs, remains seriously limited at the universities. The lack of access to these high-skill areas has socio-economic implications for learners, which could affect the general development of the country.

Teaching in the classroom at present no longer sustains the interest of learners and the age-old traditional approach with teachers as sole provider of information is no longer effective, especially given that teachers have to be preparing learners to acquire twenty first century skills such as critical thinking (Scott 2015). In recent years, technology has played a significant role in transforming education to more progressive and interactive activities (Al-Hariri & Al-Hattami, 2017, Koh, Chai, & Lim, 2016 and Kotoka, & Kriek, 2014). However, Khine et al. (2016) argue that, the use of technology itself does not produce positive results in quality of learning and learners' achievement. In their work, they examined studies on TPCK in various countries and reported findings from (a) research conducted with student teachers in the UAE, stating that teachers must be competent in subject knowledge, pedagogical skills and technological knowledge. Therefore, there is evidence of the interplay between subject knowledge referred to in this study as Content Knowledge (CK), pedagogical skills referred to in this study as Pedagogical Knowledge (PK) and technological skills referred to as Technological Knowledge (TK), as well as the interplay of all these three skills, called the Technological Pedagogical Content Knowledge or TPCK. The study done by Khine, Ali, & Afari, (2016) focused on preservice teachers TPCK and their own achievement in ICT. They recommended that further research be conducted other countries using to larger group of pre-service teachers as well as in-service teachers.

In this study, the TPCK conceptual framework is used to collect and analyse data about in-teachers and their learners in an educational district in South Africa. This is to help understand the complex relations between the constructs of the TPCK in relation to these teachers. In my view, this may lead to positive learner achievement; hence this study hypothesises a link

between TPCK, its constructs and learner achievement (as indicated in figure 2 under section 2.4 below). The background of this hypothesis is based on the work of Shulman (1987), who proposed three knowledge domains outside the context of technology (refer to section 2.2). CK, PK, and PCK (abbreviations already stated). In order to take technology into account, this work was then extended by Mishra and Koehler (2006) to the area of teaching and learning and proposed a conceptualisation of TCK, TPK, and TPCK. They further added teachers' knowledge about technology (TK). My intention is to investigate these knowledge domains and their relationships with the TPCK and the TPK to learners' achievement with respect to the participants in this study.

1.2 Context and problem of the study

The South African Department of Education (DoE), with the aim of improving the teaching of mathematics and science in schools, initiated the Dinaledi Schools Project. This is a project established under the national strategy for Mathematics, Science and Technology (MST) Education. The project has participating schools across South Africa. In 2001, the Dinaledi Schools Project targeted 102 schools in disadvantaged areas with the aim of improving participation in mathematics and science and provided these schools with extra resources (OECD, 2008). In 2005-2009, the DoE expressed concern that the teaching of mathematics and science in schools is not often the first choice of talented mathematics and science graduates and, as a result, there is a vicious circle of poor teaching, poor learner achievement and a constant shortage of competent teachers (OECD, 2008).

Current trends show that physical sciences results have been erratic from 2012 to 2016. Table 1.1 below shows comparison of National Senior Certificate (NSC) candidates' performance by selected subjects from 2012 to 2016. In physical sciences, there was a marginal increase in the pass percentage in 2013 from that of 2012 and then in 2014 and 2016 the pass percentage declined again.

Table 1.1: Comparison of NCS candidates' performance by selected subjects, 2012 to 2016

SUBJECTS	2012		2013		2014		2015		2016	
	TOTAL WROTE	PERCENTAGE ACHIEVED	TOTAL WROTE	PERCENTAGE ACHIEVED	TOTAL WROTE	PERCENTAGE ACHIEVED	TOTAL WROTE	PERCENTAGE ACHIEVED	TOTAL WROTE	PERCENTAGE ACHIEVED
Accounting	134978	65.6	145427	65.7	125987	68.0	140474	59.6	89507	69.5
Agric. science	78148	73.7	83437	80.7	78063	82.6	104251	76.9	80184	75.4
Business Std.	195507	77.4	218914	81.9	207659	77.9	247822	75.7	173195	73.7
Economics	134369	72.8	150114	73.9	137478	68.9	165642	68.2	101787	65.3
Geography	213735	75.8	239657	80.0	236051	81.3	303985	77.0	231588	76.5
History	94489	76.0	109046	87.1	115686	86.3	154398	84.0	132457	84.0
Life Sciences	278412	69.5	301718	73.7	284298	73.8	348076	70.4	245070	70.5
Maths Literacy	291341	87.4	324097	87.1	312054	84.1	388845	71.4	257881	71.3
Mathematics	225874	54.0	241509	59.1	225458	53.5	263903	49.1	135958	51.1
Physical Sci.	179194	61.3	184383	67.4	167997	61.5	193189	58.6	119427	62.0

Source: National Senior Certificate Examination School Subject Report, 2015 & 2016.

Mpumalanga, where this study was done, is one of the nine provinces in South Africa. From table 1.2 below it is evident that Mpumalanga was one of the worst performing provinces in physical sciences in South Africa from 2013 to 2015 in the matriculation examinations. Also, learners consistently perform poorly in physical sciences compared to other subjects. The only exception is mathematics where learners consistently performs below physical sciences (DoBE 2015 & DoBE, 2016).

Mpumalanga has four regions of which Nkangala is one (See section 3.3.1). Of the four, Nkangala performs neither best nor worst, and of the four regions, it is the closest to the researcher as substantiated under section 3.3.1. These factors motivated the researcher to take interest in this part of the country for the current study.

Table1.2: Comparison of candidates' performance at 30% and above in physical science by province, 2013 to 2016

PHYSICAL SCIENCES								
PROVINCES	2013		2014		2015		2016	
	TOTAL WROTE	% ACHIEVED AT 30% AND ABOVE	TOTAL WROTE	% ACHIEVED AT 30% AND ABOVE	TOTAL WROTE	% ACHIEVED AT 30% AND ABOVE	TOTAL WROTE	% ACHIEVED AT 30% AND ABOVE
EASTERN CAPE	25218	55.8	21855	51.5	27749	45.9	27574	49.8
FREE STATE	8288	75.8	8641	69.0	9628	69.7	8436	75.5
GAUTENG	29836	75.6	29093	68.3	30548	67.7	32001	68.5
KWAZULU NATAL	50332	66.4	45143	55.8	50163	51.8	48394	57.8
LIMPOPO	30758	65.6	26691	66.7	33680	59.6	34969	62.3
MPUMALANGA	16952	65.5	15210	58.7	17528	62.6	18917	63.6
NORTH WEST	8978	74.5	8191	64.0	9090	62.0	8605	69.6
NORTHERN CAPE	2540	61.5	2082	60.4	2777	54.3	2558	57.4
WESTERN CAPE	11481	72.6	11091	70.7	12026	73.3	11164	73.8
NATIONAL	184383	67.4	167997	61.5	193189	58.6	192618	62.0

Source: National senior certificate examination school subject report, 2015 & 2016

1.3 Rationale of the study

The topic electricity was specifically chosen as it has been reported that physics teachers in South African schools find it difficult to teach electricity as a topic (Atagana, Mogari, Kriek, Ochonogor, Ogbonnaya, Dlamini & Makwakwa, 2010). Therefore, the recommendations of this current study may provide direction to improve physics teachers' capacity in this important area of physics.

Factors affecting learners' achievement in the topic electricity with reference to the use of technology to aid the learning of electric circuits have been identified by (Stavrinides, Taramopoulos, Hatzikraniotis, and Psillos 2015). Furthermore, a literature search using JSTOR, ERIC, SpringerLink, World Wide Science, Ebsco and Google Scholar on investigating the teachers TPCK and learner achievement, yielded Farrell and Hamed (2017), Alhababi (2017), Khine, Ali, and Afari (2016) and Erdogan and Sahin (2010). Alhababi (2017) found that technology is an effective tool for both teachers and learners to enhance teaching and learning using TPCK, but Farrell and Hamed (2017) found no significant correlation between in-service teachers TPCK and learners' achievement. Khine, Ali, and Afari (2016) and Erdogan and Sahin (2010) focused on pre-service teachers TPCK and the pre-service teachers own achievement. Ali, and Afari (2016) found moderate positive correlation between achievement and TPCK and Erdogan and Sahin (2010) found that TPCK significantly predicts Grade Point Average (GPA) scores and that TPCK plays an important role in pre-service teachers' achievement. The two studies found to focus on in-service teachers TPCK and learner achievements (Alhababi 2017 and Farrell and Hamed 2017) produced conflicting findings. They also recommended further studies in this area of TPCK and learner achievement.

Naledi Pandor (2010), while Minister of Education in South Africa, stated that South Africa has to triple the number of grade 12s who pass grade 12 with a pass mark in mathematics and physical sciences in order to keep up with the rest of the world. Maree (2010) also noted that the situation of black learners in this regard is particularly worrying. This study seeks to collect and analyse data about teachers and their learners in an educational district in South Africa. The TPACK framework is used as lens and will be used to help understand the complex relations between the constructs of the TPACK in relation to these teachers.

During literature search it was it was found in a study by Lin, Tsai, Chai, & Lee (2012) who recommend in their study that future studies of teachers' TPACK should focus more research on issues such as teachers' TPACK and age, teachers' TPACK and gender, as well as teachers' use of technology. They contended that research into the above issues may help by highlighting recommendations that could improve science teachers' knowledge of integrating educational technologies in teaching with the view of improving learners' performance. Farrell et al. (2017) also recommended future studies in relationship between TPACK and its constructs as well comparing learner achievement with and without the use of technology. Therefore, this study will contribute in this regard by investigating physics teachers' TPACK, and its relationships with their demographics and how they relate in the context of the study.

In their study, Jang & Tsai (2012), indicated a new direction with regards to the TPACK model. They recommended future research by suggesting an investigation into specific strategies science teachers use when integrating technology into their classroom. To address this

recommendation, it was decided to investigate what technologies physics teachers with technological Pedagogical Content Knowledge use in teaching electricity. This study will also aim to investigate the relationship between physics teachers' technological and pedagogical content knowledge and learners' achievement.

1.4 Aim of the study

The aim of the study is to investigate the relationship between physics teachers' technological pedagogical content knowledge (TPCK) and their grade 11 learners' achievement in electricity. Teachers' TPCK and its relationship with its constructs, as well as teachers' demographics, teachers' technology use and what technologies teachers with TPCK use in teaching grade 11 electricity, (as recommended by Lin, Tsai, Chai, & Lee (2012)) will also be investigated. The relationship between the grade 11 learners' responses on their teachers' TPCK will be compared with the teachers' own responses on their own TPCK of the TPCK constructs: Technological and Pedagogical Content Knowledge (TPCK), Content Knowledge (CK), Pedagogical Knowledge (PK), Technological Knowledge (TK), Technological Content Knowledge (TCK), Pedagogical Content Knowledge (PCK) and Technological Pedagogical Knowledge (TPK). Lastly, the sections of electricity which teachers neglect to teach will be investigated literature search did not reveal any research findings in this area of study.

1.5 Research questions

This study seeks to collect and analyse data about physics teachers and their learners in an educational district in South Africa. The TPACK framework is used as lens to help understand the complex relations between the constructs of the TPACK in relation to these teachers. The research was done with grade 11 learners subjected to the teaching of electricity by their own Physics teachers. Therefore, the learners' achievement as mentioned under section 1.4 was on electricity and the above aims of the study will be researched using the following research questions:

1. What is the relationship between physics teachers' technological and pedagogical content knowledge and their learners' achievement?
2. What is the relationship between physics teachers' technological and pedagogical content knowledge and their demographics, such as qualifications, teaching experience, age and gender?
3. What is the relationship between the six TPCK constructs and the TPCK from the teachers' perspective?
4. What is the relationship between the six TPCK constructs and the TPCK from the learners' perspective?
5. Is there a corroboration between the teachers' perspective and the learners' perspective on the following TPCK constructs:
 - Technological Knowledge (TK),
 - Content Knowledge (CK),
 - Pedagogical Knowledge (PK),

- Technological Content Knowledge (TCK),
 - Pedagogical Content Knowledge (PCK),
 - Technological Pedagogical Knowledge (TPK) and
 - Technological and Pedagogical Content Knowledge (TPCK) of the participating teachers and learners?
6. What technologies do physics teachers with technological pedagogical content knowledge use in their electricity lessons?
7. What sections of electricity in the CAPS physics syllabus are teachers neglecting to teach?

1.6 Limitations of the study

The limitations of the current study include the following: Firstly, data about physics teachers' TPCK and their technology integration in the teaching of electricity were collected using questionnaires (teacher and learner questionnaires). Secondly, the lesson plans the teachers used in the teaching of their lessons. Even though the department of education expects teachers to have lesson plans when they are preparing for lessons, I found that it is not actually happening. So, teachers resort to already prepared lesson plans from textbook writers and sometimes from the department itself. Therefore, it was difficult to get the true teacher intention during lesson preparation as I had wanted. These made the data collected not sufficient as the information collected in from data may only reflect the opinions and probable intentions of the participants. This was a quantitative study with limited support qualitatively. Therefore, classroom observation and video recordings of the lessons would have been more appropriate have given the researcher vivid information about the technologies the participating teachers used in the teaching of chosen topics and hence concrete ideas about their TPCK.

In my study, the achievement test was given to the teachers to use to test the learners after they taught the topic of electricity. There is a possibility that these teachers taught their learners with the questions on the test in mind. In other words, teachers may have been dishonest and coached their learners for the test. Therefore, we recommend that future research in the same vein should endeavour to control and monitor the completion of the achievement test. This would eliminate any possible dishonesty from schoolteachers who may see the research as something used to expose their incompetence. This in my view will add more credibility to the findings of the research.

Also, this study only focused on grade 11 and electricity as a topic. This is only one of many grades and many topics in physics. With these limitations, we are not attempting to generalise the findings of this study to other topics and other grades.

1.7 Conclusion

The study's orientation was established in this chapter. The background, context of the study and the research questions were presented. In addition, the rationale of the study as well as the limitations of the study were presented.

CHAPTER 2

THEORETICAL FRAMEWORK AND LITERATURE REVIEW

2.1 Introduction

To place this study in perspective, a literature survey was conducted to present issues on the technological and pedagogical content knowledge (TPCK) framework as well as teaching of school electricity specifically. The TPCK framework, as introduced by (Mishra & Koehler, 2006), is the theoretical framework used in this study.

2.2 TPCK Theoretical framework

The “Technological, Pedagogical, and Content Knowledge (TPCK)” is a model that describes a framework consisting of different knowledge domains teachers need to acquire to become competent in successfully integrating technology in the teaching and learning processes in their various classrooms (Koehler, Mishra, Kereluik, Shin, & Graham, 2014). The Technological Pedagogical Content Knowledge (TPCK) framework is based on Shulman’s work (Shulman,1986,1987) which states that Technological Aspects of Knowledge (TK) need to be considered as an integrated part of other relevant aspects of teacher knowledge, namely Content Knowledge (CK), Pedagogical Knowledge (PK), and their intersections (see Figure 1) below (Krauskopf, Zahn & Hesse, 2012).

Since its proposal by Mishra and Koehler (2006), the TPCK has become a leading conceptual framework. Researchers have used it and are continuing to use it in two ways (i) to research and develop teachers’ integration of digital technologies in teaching and learning and (ii) to

define the competences pre - service and in - service teachers should develop in order to integrate technology in the 21st century education, (Kopcha, Ottenbreit-Leftwich, Jung, & Baser, 2014). Therefore, the TPACK framework has “influenced theory, research, and practice in teacher education and teacher professional development” (Kopcha et al., 2014, p. 101).

This study will essentially focus on the Technological Pedagogical Content Knowledge (TPCK), and its constructs - Content Knowledge (CK), Pedagogical Knowledge (PK), Technological Knowledge (TK), Pedagogical Content Knowledge (PCK), Technological Pedagogical Knowledge (TPK) and Technological Content Knowledge (TCK).

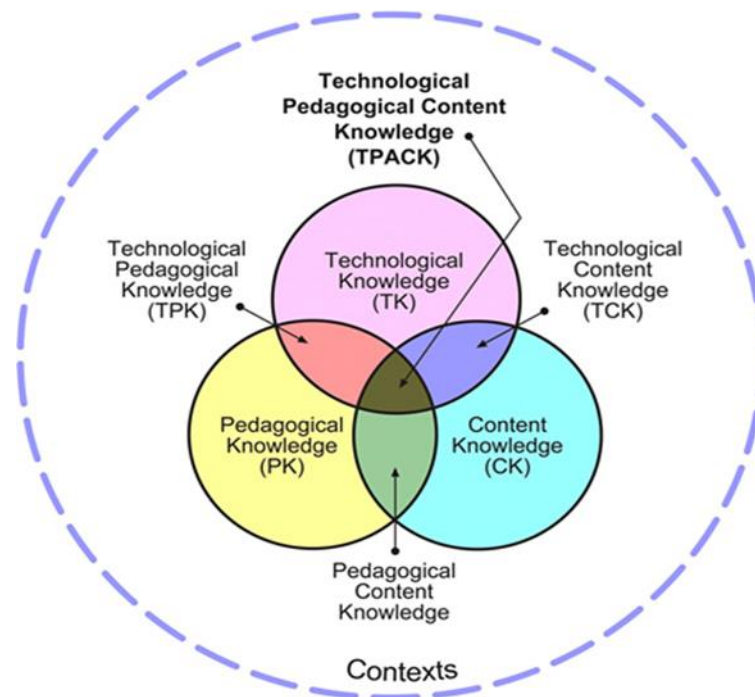

Figure 1: TPACK framework according to Koehler and Mishra, 2009.

Technological pedagogical content knowledge was introduced to the educational research field as a theoretical framework for understanding teacher knowledge required for effective technology integration (Mishra & Koehler, 2006). The TPCK framework abbreviation is sometimes referred to as TPACK to make it easier to remember and to form a more integrated whole of the three basic components of knowledge addressed: technology, pedagogy, and content (Thompson & Mishra, 2007). In figure 1, an essential understanding of teaching content with appropriate pedagogical methods and technologies are at the intersection of these three knowledge types. They were defined by (Schmidt, Baran, Thompson, Mishra, Koeler & Shin, 2009) as:

2.2.1 Technology Knowledge (TK):

Technology knowledge refers to the knowledge about various technologies, ranging from low-tech technologies such as pencil and paper, to digital technologies such as the Internet, digital video, interactive whiteboards, and software programmes.

Technology knowledge is always changing, because technology itself is changing daily. This make defining it difficult compared to knowledge domains in the TPACK framework such as pedagogy and content knowledge (Koehler and Mishra 2009). The definition of Technology knowledge can become obsolete in a short time. Hence acquiring TK can only be on going and a lifelong developmental process. TK enables teachers to complete different teaching tasks using technology and to develop different ways of teaching various topics for instance.

2.2.2 Content Knowledge (CK):

Content knowledge is the “knowledge about actual subject matter that is to be learned or taught” (Mishra & Koehler, 2006, p. 1026). Teachers must know the content they are teaching. They also have to know how the nature of knowledge is different for various content areas.

Content knowledge (CK) is teachers’ knowledge about the subject matter to be learned or taught in a specific subject like physics, chemistry or mathematics to mention a few and at the right level. This knowledge domain is vast, and so Shulman (1986) listed as components of CK to include knowledge of concepts, theories, ideas, organizational frameworks, knowledge of evidence and proof, as well as established practices and approaches toward developing such knowledge. For instance, a physics teacher, not having comprehensive content knowledge, will lack knowledge of scientific facts and theories, the scientific method, and evidence-based reasoning.

2.2.3 Pedagogical Knowledge (PK):

Pedagogical knowledge refers to the methods and processes of teaching and includes knowledge in classroom management, assessment, lesson plan development and student learning.

It is teachers’ deep knowledge about the processes and practices of teaching and learning. They include, but not limited to, overall educational purposes, values, and aims. This broad form of knowledge pertains to understanding of how learners learn, general classroom management skills, lesson planning, and learner assessment. A teacher with deep pedagogical knowledge understands how learners construct knowledge and acquire skills. As such, pedagogical knowledge requires an understanding of cognitive, social, and developmental

theories of learning and how they apply to learners in the classroom (Koehler and Mishra 2009).

2.2.4 Pedagogical Content Knowledge (PCK):

Pedagogical content knowledge refers to the content knowledge that deals with the teaching process (Shulman, 1986). Pedagogical content knowledge is different for various content areas as it blends both content and pedagogy with the goal of developing better teaching practices in the content areas.

PCK is a combination of a teacher's content and pedagogical knowledge. It is what curriculum, assessment, teaching, learning, and reporting. In addition, knowledge of the learner such as common misconceptions and ways of looking at them, how learners are forging connections among different content-based ideas, learners' previous knowledge, alternative teaching strategies that help different learners to grasp the content, and the capability to explore different ways of looking at the same idea are some of the main ingredients that make teaching effective (Tambara, 2015).

PCK was defined recently at an international summit on science PCK as the knowledge of, rationale behind, planning for, and act of teaching a specific piece of subject matter, in a specific context, to support learner learning of the material (Gess-Newsome, 2015). Since its conception of PCK as a construct, research has been conducted within various education disciplines and many frameworks have evolved in an attempt to explain the complex nature of PCK (Gess-Newsome, 2015; Lee, 2011; Loughran, Berry, & Mulhall, 2012). Notwithstanding the attention, PCK has received through research in teaching and learning, various studies

across the educational spectrum have indicated that teachers are still grappling with development of this knowledge base and its applications in the teaching and learning process (Rice and Kitchel, 2016). Hence, Hashweh, (2005) and Nilsson, (2008) agree that years of experience in teaching and a framework are the most effective ways to develop teachers PCK.

2.2.5 Technological Content Knowledge (TCK):

Technological content knowledge refers to the knowledge of how technology can create new representations for specific content. It suggests that teachers understand that by using a specific technology, they can change the way learners practice and understand concepts in a specific content area.

TCK, is at the intersection of TK and CK (see figure 1 and 2). The knowledge domain combines technology and content knowledge. Technology permeates almost everything we do in the world today, and teaching and learning are not left behind. Teachers more than ever before needs to master more than the subject content to be able to teach their specialised subject areas adequately. In addition to all the specialised knowledge and skills, they need to teach, they also need to have a deep understanding of the manner in which the subject content can be taught by the application of particular technologies. Teachers need to understand which specific technologies will be best suited for addressing subject content learning in their specialised subject areas (Koehler & Mishra, 2009).

2.2.6 Technological Pedagogical Knowledge (TPK):

Technological pedagogical knowledge refers to the knowledge of how various technologies can be used in teaching and understanding that using technology may change the way teachers teach.

TPK evolved as one of the constructs of TPCK. It is the knowledge teachers need to understand how particular technological tools can help both the teaching and learning processes in the classroom by introducing new teaching strategies (Kurt, 2018). TPK also deals with the understanding of how such tools can be used in the classroom in ways that are appropriate for the specific the lesson to be delivered.

2.2.7 Technological Pedagogical Content Knowledge (TPCK):

Technological pedagogical content knowledge refers to the knowledge required by teachers for integrating technology into their teaching in any content area. Teachers have an intuitive understanding of the complex interplay between the three basic components of knowledge (CK, PK, TK) by teaching content using appropriate pedagogical methods and technologies.

To integrate technology in the classroom successfully demand teachers to acquire the specialised knowledge of technology, pedagogy, content, and how these core components of teaching intersect each other (Archambault & Crippen, 2009). Abbitt, (2011) agree that research on these three knowledge domains as well as the integration of technology in K–12 classrooms, have emerged as a representation of the knowledge required to use technology in an educational setting in ways that are contextually authentic and pedagogically appropriate. Koehler & Mishra, (2009) emphasised these accessions when they said, TPCK is an emergent form of knowledge that goes beyond all three “core” components (content, pedagogy, and technology). It results from the interactions between content, pedagogy, and technology knowledge. Underlying truly meaningful and deeply skilled teaching with technology is TPCK, which is different from the knowledge of all three concepts individually.

Therefore, teachers need to develop fluency and cognitive flexibility not just in each of the key domains (technology, pedagogy, and content), but also how these domains and contextual parameters interrelate, so that they can effectively create their own solutions continually to become effective teachers.

Since the TPCK framework was proposed by Mishra and Koehler in 2006, over 500 TPCK-based studies of teachers' technology integration knowledge have been presented and published till date. Most of these studies were focused on development of preservice teachers' TPCK (Hofer & Harris 2012). Luik, Taimalu, and Suviste, (2018) published a research done in Estonia which aimed to: (a) develop the TPCK scale and to validate it in the Estonian context; and (b) describe the perceptions of TPCK by Estonian pre-service teachers and to find relationships between TPCK components and pre-service teacher demographics (age, gender, study level). In this research, they did a comprehensive review of literature on the work that has been done on the TPCK framework the world over. For the pose of this study I will just mention what they found when they reviewed literature without listing the actual publications. So, in their comprehensive review, they found the following:

1. *there are several papers, which deal with developing valid and reliable instruments for measuring teacher evaluations of their knowledge according the TPCK model in different countries. However, more studies of teachers from different countries are still needed to explore possible cultural differences in TPCK perceptions among pre-service and in-service teachers (Koh, Chai, & Tsai, 2010).*
2. *instruments using the TPCK framework have been used to measure evaluations of knowledge areas in the case of pre-service teachers., as well as in-service teachers and studied student perceptions of college teacher knowledge according to the TPCK framework*
3. *because these self-reported questionnaires do not measure real knowledge levels, results obtained with these instruments are called TPCK perceptions in some studies, teacher opinions on TPCK self-efficacy in others. Some of these studies only use theory-based factors constructed without exploring the construct validity of the instrument.*

4. *there are several studies indicating a greater or lesser number of factors than seven proposed initially by (Mishra and Koehler, 2006).*
5. *both pre-service teachers and in-service teachers have rated all their perceptions significantly higher than neutral. Results vary in this regard to the highest and the lowest ratings in different studies, and therefore the results are controversial.*
6. *the relationship between age and TK perceptions is more evident in the case of in-service teachers but not so much in the case of pre-service teachers and this result are also controversial across different studies*
7. *the results exploring gender differences are also controversial in the case of in-service teachers, even within same countries.*

They concluded their thorough literature review of the studies presented and published

TPCK by saying that:

8. *as the results of the previous studies indicate, there is no scale using the TPCK framework, which is suitable for all settings – in-service and pre-service teachers, different subjects and different countries. Controversial results have also been found in terms of how demographic data correlates with TPCK components and which TPCK components are rated higher.*

They therefore re-echoed what Koh et al. (2010) said that, more studies of TPCK in different countries are needed. However, Luik et al. (2018) did not report on the researches done by Khine et al. (2016); Erdogan et al. (2010) and Farrell et al. (2017), who looked at relationships between teachers' TPCK, and achievement as stated earlier under section 1.3. Therefore, this current study seeks to contribute by looking at relationships between physics teachers' TPCK and their learners' achievement among other things in the Mpumalanga province of South Africa as stated in the aim and the research questions under sections 1.4 and 1.5 respectively.

The above list of eight categorisations of many publications on the TPCK framework is to help place this current study in perspective.

2.3 A few epistemological issues/ current challenges for the TPCK framework

According to Graham (2011), even though the framework has clearly identified essential variables or constructs of the TPCK, much work needs to be done to develop construct clarity. He contends that there is need to develop precise definitions for each of the constructs in the TPCK framework. Graham (2011) posits that Cox in 2008 carried out a comprehensive analysis of literature and found 13 different definitions of TCK, 10 for TPK and 89 for TPCK. One of major confusion pointed out by Graham is that PK considerations are often mentioned in the context of TCK, yet according to the TPCK frameworks, there is no overlap between PK and TCK (see figure 1).

The lack of clarity of definitions prompted a number of researchers to attempt to clarify the definition and scope of the “technological knowledge” under investigation by identifying a particular flavour of TPCK. For example, Angeli and Valanides (2009) used the term ICT-TPCK to signify a focus on the use of information and communication technologies (ICT); Lee & Tsai (2010) used the term TPCK-W to represent a focus on web technologies; (Doering, Veletsianos, Scharber, & Miller 2009; and Doering & Veletsianos, 2007) used the term G-TPACK to represent a focus on geospatial (geographic) technologies.

Cox (2008) also tried to deal with the lack of precise definition for technology by trying to differentiate transparent technologies from emerging technologies. So, technologies like the

pencil, the chalkboard, the book, etc used universally in a classroom, were referred to as transparent technologies. In contrast, emerging technologies were defined as digital tools currently used in the classroom.

In an attempt to further clarify this issue, Koehler and Mishra (2009) stated that the definition of TK as used in their TPACK framework, is close to that of Fluency of Information Technology (FITness), as suggested by the Committee of Information Technology Literacy of the National Research Council (NRC, 1999). They argue that:

FITness goes beyond traditional notions of computer literacy to require that a person understand information technology broadly enough to apply it productively at work and in their everyday lives, to recognise when information technology can assist or impede the achievement of a goal, and to continually adapt to changes in information technology. FITness, therefore, requires a deeper, more essential understanding and mastery of information technology for information processing, communication, and problem solving than does the traditional definition of computer literacy. Acquiring TK in this manner enables a person to accomplish a variety of different tasks using information technology and to develop different ways of accomplishing a given task. This conceptualisation of TK does not posit an "end state", but rather sees it developmentally, as evolving over a lifetime of generative, open-ended interaction with technology (p. 64).

Forsell (2011: p. 9) also said "assessing TPACK requires focus on a specific technology in a particular context and in support of a clear set of curricular objectives, and it will require some measure of teachers' PCK as well".

From the previous discussion, it is therefore viable to apply broad definitions for the constructs of the TPACK framework, and researchers should apply these broad definitions to suit their specific technologies in particular contexts, in support of clear set curricular objectives.

Therefore, to distinguish between the seven constructs of the TPCK, Lin, et al (2012) attempted the definitions of each as shown below, using previous studies like (Chai, Koh, Tsai & Tan, 2011); Cox & Graham, 2009; Koehler & Mishra, 2009). In my view, researchers may use aspects of these broad definitions in their specific situations as it may apply to them.

2.3.1 Technological Knowledge (TK):

The general knowledge of emerging technologies such as using computer simulations and YouTube videos.

2.3.2 Pedagogical Knowledge (PK):

The general knowledge of instruction, including instructional principles, psychology of students, classroom management and teaching strategies.

2.3.3 Content Knowledge (CK):

The subject matter knowledge such as scientific knowledge.

2.3.4 Technological Content Knowledge (TCK):

The knowledge of applying emerging technologies to represent specific subject matter knowledge, but independent from pedagogical purpose. For instance, the knowledge of

employing computer simulations to represent the growth and decline of an animal population can be categorised as TCK.

2.3.5 Technological Pedagogical Knowledge (TPK):

The knowledge of applying emerging technologies in pedagogy of all subject domains rather than being restrictively aimed at specific content knowledge, such as the knowledge of engaging a web-based forum to be a Computer-Supported Collaborative Learning (CSCL) environment.

2.3.6 Pedagogical Content Knowledge (PCK):

The knowledge of transforming specific content knowledge into a comprehensible and accessible form for learners via a pedagogical approach, such as the knowledge of how to teach certain scientific concepts. However, the critical difference between PCK and TPCK defined in this paper is the application of emerging technologies.

2.3.7 Technological Pedagogical Content Knowledge (TPCK):

The knowledge of applying emerging technologies to enhance students' learning in specific subject matter knowledge, such as using Google Earth to help students experience the process of inquiry and learn the concepts.

These definitions provided by Lin et al (2012) are in line with that of Schmidt et al (2009). Lin et al (2012) also place emphasis on the fact that they are referring to emerging technologies and not the old technologies referred to by (Cox, 2008) as transparent technologies. As a result, it is my view that technology integration in the classroom today (digital tools), should not be confused with the transparent technologies (pencil, the chalkboard, the book, etc). The lack of clarity in the TPCK theory mentioned earlier which has been discussed by researchers led to the emergence of alternative models of TCPK for the purpose of clarity of their research. These models simply indicate that the focus is on emerging technologies and not the transparent ones. Examples are as discussed earlier where Angeli and Valanides (2009) used the term ICT-TPCK to signify a focus on the use of information and communication technologies (ICT); Lee & Tsai (2010) used the term TPCK-W to represent a focus on web technologies; (Doering, Veletsianos, Scharber, & Miller 2009; and Doering & Veletsianos, 2007) used the term G-TPACK to represent a focus on geospatial (geographic) technologies.

2.4 Hypothetical relationship between TPCK, its constructs and learners' achievement

The focus of this study is to investigate to what extent teachers' technological pedagogical content knowledge (TPCK) affects learners' achievement in their study of electricity. It is therefore hypothetically theorised in this study that teachers' TPCK has a remarkable connection with their learners' achievement. Figure 2 below depicts the hypothetical connections between the TPCK as teacher knowledge, its constructs and then learners' resultant achievement.

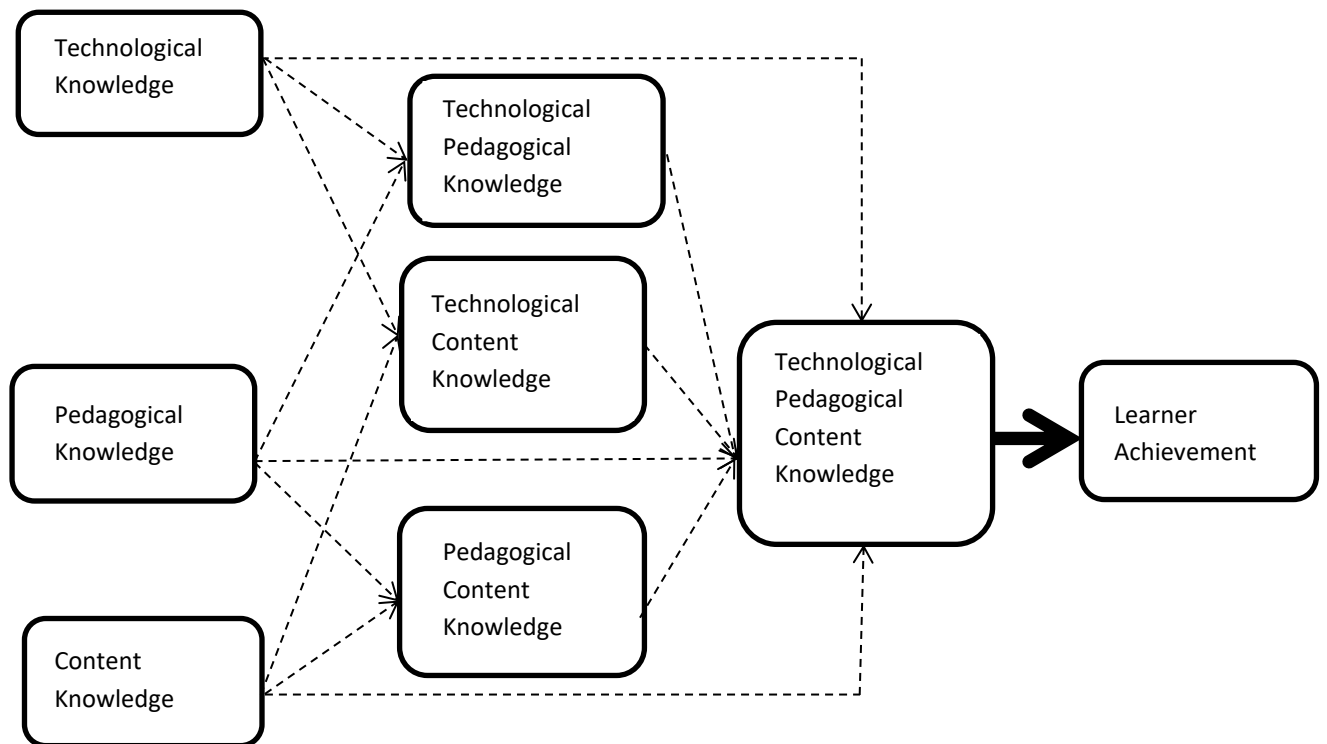

Figure 2: A hypothetical model of the interrelationships among TPCK constructs and learners' achievement.

To answer the research questions, it is envisaged that the TPCK for subject-specific pedagogies would yield a model with the seven TPCK factors (See Figure. 2) as postulated by Mishra & Koehler (2006) and modified by (Chai, Koh, Tsai, & Tan, 2011). For this study, the model of TPCK components as set up in Figure 2 is based on the framework articulated by Chai, et al (2011). The interaction between the three main components (TK, PK, and CK) gives rise to the other four derived constructs (TPK, PCK, TCK, and TPCK). As such, it is hypothesised that TK, PK, and CK contribute both directly and indirectly to the four derived constructs, as well as learner achievement as illustrated in Figure 2. The hypothesis in figure 2 is that there is relationship between TPCK, its constructs and learners' achievement, so it is vital that a discussion is presented on learner achievement.

2.5 Learner achievement

Academic achievement as the outcome of education, is defined as the extent to which a student, teacher or institution has achieved their educational goals Ward, Stoker, Murray-Ward (1996). Academic achievement is commonly measured by examinations or continuous assessment, yet there is no general agreement on how it is best tested or which aspects are most important, procedural knowledge such as skills or declarative knowledge such as facts. No general agreement regarding how best to test academic achievement, or which aspects of this are the most important to test; procedural knowledge such as skills or declarative knowledge such as facts (Green, 2013). In my study, learner achievement will be measured using a test (see section 3.3.3.5) in the form of an examination as commonly used. This is to enable us to determine the learners' achievement in the topic of electricity after their teachers teach the learners electricity.

The first education white paper had referred to the fact that “only one in five black students choose Physical Sciences and Mathematics in Standard 8, and the trend of performance in the senior certificate examinations has been low overall” (DoE, 1995, Ch. 5, Section 48). Ten years later, the Department of Education's grade 3 and grade 6 systemic evaluation reports (DoE, 2003; DoE, 2005) continued to indicate generally poor achievement.

The [OECD], which is an international organisation promoting the economic and social well-being of people around the world, concluded in their research report titled 'Reviews of National Policies for Education, South Africa', that from an absolute and comparative

perspective, and in the assessment of most commentators, learners' levels of achievement in South Africa are not commensurate with the financial investment being made. This conclusion was reached based on both local and international measures and studies of learning achievement available at the time of research. (OECD, 2008).

2.5.1 Learner achievement and teacher factors

Mamutse and Ramnarian, (2014) have grouped factors affecting learners' achievement into the following: teacher factors, learner factors, curriculum factors, school factors, and resource factors. These are broad groups and each of them can be subdivided into additional factors.

2.5.1.1 Teacher factor in terms of learner achievement

The focus of this discussion is on teacher factors in particular as they relate to learner achievement in their study of electricity. Teacher factors are related to learner achievement (Nyanhi & Ochonogor, 2014), who found in their study that in South Africa, poor achievement is also attributable to teacher factors.

2.5.1.2 Teacher factor related to qualifications

Furthermore, this conclusion is confirmed by other studies too aimed at determining factors associated with high school learners' poor performance. Mji and Makgato, (2006) found that many science teachers are unqualified to teach physical sciences due to insufficient (in terms of) subject content training and lack of professional qualifications. This was also echoed in a

study by Kriek and Basson (2008) amongst grade 10 – 12 physical sciences teachers, which found that these teachers' pedagogical content knowledge (PCK) will be adversely affected. Chin and Kayalvizhi (2002) found that in cases where teachers' PCK is inadequate, they may not be able to teach learners how to learn with respect to inquiry-based learning, such as the identification of variables amongst others.

2.5.1.3 Teacher factor related to assessment

In addition to the lack of suitable qualifications and PCK, teachers have also been found to be conservative in the way they teach and assess learners (Chan, 2010; Ramnarain, 2010). For instance, in a study of two schools (school A and school B), Chan (2010) found that there was a relative conservative feature of school (A) which imposed certain conservative measures on her teacher requirements for formal assessment of students' learning. However, school (B) was relatively open in structure and collegial in culture, so the formal assessment policy was in fact the result of a unanimous decision among the relevant teachers.

2.5.1.4 Teacher factor related to teaching

It is the view of Chan (2010) that teachers tend to adopt and maintain a traditional teacher-centred teaching approach. According to radical constructivists, a teacher or facilitator should position learners within the environment they are learning and engage them in building their own mental model with limited support provided (Kotoka and Kriek, 2014). However, teachers would most likely resist giving up control of teaching and learning in their classrooms (Anderson, 2002). This posture of teachers could become a problem for promoters of the

constructivists, as teachers tend to maintain the traditional teacher- centred teaching approach.

2.5.1.5 Teacher factor related to teacher beliefs

Teachers' beliefs about how to teach has also been found to influence the degree to which they approach their teaching, and this has implications for learners' learning and, as a consequence, their achievement. Stols and Kriek (2011) found that teacher' beliefs about the perceived usefulness of and beliefs about their level of technological proficiency are the most important predictors of teachers' intended and actual usage of technology. While Ogbonnaya, (2011) describes an overall system that guides teachers' teaching decisions and classroom instructional behaviours, Kotoka and Kriek, (2014, p. 100) confirmed this in their study on the impact of computer simulations as interactive demonstration tools on the achievement of grade 11 learners in Electromagnetism. They said that "Although the performance of the learners was established, the role of the teachers when selecting the most effective instructional designs to enable learners to understand the fundamental ideas in electromagnetism could not be overlooked" (p. 100)

2.5.1.6 Teacher factor related to teacher teaching experience

The last of the teacher factors to be discussed will be teachers' teaching experience. Ogbonnaya (2007), Rivkin, Hanushek, & Kain (2005) as well as Betts, Zau, & Rice (2003) all showed that learners of experienced teachers achieved better than learners of inexperienced teachers. Teaching experience refers to the number of years the teacher has taught the

subject at school level, practiced as education departmental facilitator or inspector or also examiner for the particular subject; for this study, the particular subject is physics.

Even though the old common adage remains, “experience is the best teacher,” some researchers found the contrary to be true in their findings. According to Rice, (2010: p. 2) “Experience matters, but more is not always better. The impact of experience is strongest during the first few years of teaching; after that, marginal returns diminish. Teachers show the greatest productivity gains during their first few years on the job, after which their performance tends to level off.” This finding was confirmed by Buddin and Zamarro, (2009) in their research conducted in Los Angeles Public Schools entitled, ‘What Teacher Characteristics Affect Student Achievement?’ They found that teachers’ experience does not in fact have any substantial effect on learners’ achievement. However, Ogbonnaya (2011) argue that the levelling of the benefit of experience could be due to more experienced teachers not continuously developing and acquiring more knowledge and skills after many years of teaching. Ergo, if more experienced teachers are motivated to continue to develop, they should become more knowledgeable; consequently, reflecting in their learners’ achievement.

2.5.2 Learner achievement in electricity

The final year of high school in South Africa is grade 12. Each grade 12 learner writes his or her end of year examinations based on the South African National Curriculum Statement (NCS). The results are analysed and used to measure the achievements of the learners in all

the subjects. A diagnostic report on the results is released every year. In these reports, key subjects are analysed question by question and presented to the teachers of the respective subjects. From the year 2011 to 2013, the reports have indicated that questions relating to electricity were poorly answered in the physical sciences paper 1. (the physics paper.) (DoBE, 2011, DoBE, 2012 and DoBE, 2013). Only in 2014 was it reported that the electricity section was satisfactorily answered (DoBE, 2014). Below are a few common errors learners make with regard to questions concerning electricity as identified in these reports:

Some Common learner errors:

- (a) Many candidates forfeited marks for one of the following reasons:
- substituting without writing the formula (DoBE, 2014: p. 183).
 - using the incorrect formula e.g. $R_p = \frac{1}{R_1} + \frac{1}{R_2}$ instead of $\frac{1}{R_p} = \frac{1}{R_1} + \frac{1}{R_2}$ (DoBE, 2014: p.183).
- (b) A number of candidates could not calculate the gradient of Ohm's Law graphs. Finding the correct coordinates from the graphs was also a huge challenge to many candidates as well as interpreting the scale of the graphs. (DoBE, 2014: p. 183).
- (c) Learners did not understand Ohm's Law and its interpretation hence cannot apply it to graphs and circuit calculations. (DoBE, 2014: p. 183).

Dega, (2012) posit that the concepts in electricity are invisible and unfamiliar to learners' everyday experiences. As a result, Rutten, van Joolingen and van der Veen, (2012) believed that the use of appropriate interactive physics simulations available for teaching electricity concepts is important to simplify the complex and invisible nature of these concepts, as they

are designed to be interactive, engaging, and also to make explicit certain visual representations. In my view, this is where the physics teachers' TPCK is very important and needs to be investigated; so that a determination of physics teachers' TPCK and its relationship with learners' achievement will help us make recommendations to empower both teachers and learners positively.

In order to improve learner achievement in this particular section of the physics paper, the following suggestions were made in the 2014 reports (DoBE, 2014: p. 184). As also stated in previous years reports, the last point (i) strongly recommends training for the teachers to enable them to teach the electricity section better.

Suggestions for improvement:

- (a) There should be ongoing revision of electric circuits done in grades 10 and 11.
- (b) Teachers should have learners practice more examples of circuits with branching and using all electrical variables (electric current, resistance, power and potential difference).
- (c) Teachers need to perform more experiments to explain why each component is connected in a particular way. For example, voltmeters are always connected in parallel.
- (d) More exercises involving explanations should be done in class.
- (e) Graphs (sketching and interpretation) should be an integral part of teaching in all knowledge areas.

- (f) Each learner should be given a graph book for physics to help them learn how to plot graphs. Problems involving graphs should be done in all sections in physics and the graph book should be utilised by learners for these problems.
- (g) When teaching internal resistance in grade 12, all concepts done in grades 10 and 11 should be included in classwork and homework exercises so as to encourage learners to revise the basic concepts of electricity.
- (h) Prescribed experiments must be done.
- (i) There is need for a focused training on current electricity (both theoretical and practical work) so that it can be taught more effectively.

The aim of this study is to investigate the relationship between physics teachers' technological pedagogical content knowledge (TPCK) and their grade 11 learners' achievement in their study of electricity. The suggestions for improvement as stated above could help learners' achievement if the teachers have the necessary TPCK and the learners become motivated through their teachers' teaching approaches to participate actively in the teaching and learning process to learn. This could help address all the issues raised from (a) to (i) as learners will could visualise the concepts in electricity better and become motivated to learn more and take ownership of their learning.

2.5.3 Electricity as a high school physics topic

Gunstone, Mulhall, (2008) have argued that there are two reasons for such concern regarding electricity in research. The first reason is that electricity is seen as a central area of physics curricula at all levels of education (primary, secondary and tertiary). The second reason is that the concepts of electricity are particularly problematic – they are highly abstract and complex in ways that make their understanding both centrally dependent on analogies.

Electricity and electric circuits are introduced to high school learners in South African schools as early as grade 8 (DoBE 2011a). This is continued in grade 9, 10, 11 and 12 (DoBE 2011b). Electricity is a very important topic in the South African high school syllabus as learners' knowledge of electricity will help them in other topics such as electromagnetism, alternating current electricity, electric generators and motors and their applications in our day to day use to name but a few. Ultimately, electricity and magnetism in the grade 12 matriculation examinations covers roughly 35 marks out of 150 marks (DoBE, 2011: p. 1183). Therefore, these 35 plus marks out of 150 marks makes electricity and magnetism the second most valuable topic after mechanics. In the same CAPS document, three grade 11 topics are selected for examination in grade 12; electric circuits taught in grade 11 is among these three topics. In my view as a teacher of physics and the Head of the Science Department, learners stand to benefit much when they have a good knowledge of basic electricity in the following ways:

1. Learners' alternative conception could be reduced. For example, Dega, Kriek and Mogese (2013: p. 1904) in their study indicated that undergraduate students still hold alternative conceptions on electric field (for example, that electric field flows from positive to negative). This was the case even though these students had completed high school and taken physics

as a subject. By placing emphasis on understanding basic electricity, students' alternative conceptions, which learners have in this regard, could be reduced.

2. More learners could pass Physical Sciences at grade 12 level. This view is supported by (Kwanda, Kriek, Basson and Lemmer, 2011: p. 294) when they said: "The misconceptions students have in basic electric circuit generally affect the overall performance of physics and hence physical sciences as a subject"

3. If learners achieve a better average in physical sciences at grade 12 level, there could be a positive impact on the science faculties at universities as students with conceptual understanding could improve the quality and quantity of intake into the science-related disciplines.

4. The science-related skills shortage could be addressed in South Africa as more learners could be admitted to pursue science-related disciplines while at universities, Universities of Technology as well TVET Colleges and become electricians.

5. Lastly, all the above benefits could help learners' decision-making capabilities when it comes to the usage and handling of electricity as well as electrical devices, especially with current power shortages and the initiation of load shedding.

2.6 TPCK in the teaching context

Using a new TPCK in the classroom requires teachers to learn. Niess, (2008: p. 5301) while describing the developmental process of mathematics teachers acquiring TPCK, stated that “These teachers are confronting an innovation – an innovation that integrates a new technology tool, new teaching and learning strategies and a revision of how they know their subject matter content as a result of the availability of the new technology”. This is why this current study is looking into physics teachers’ TPCK and their learners’ achievement in the topic electricity. These finding will inform if the teachers are implementing innovation that integrates new technologies in their teaching by finding out if there is a relationship between their TPCK and learner achievement as hypothesised in figure 2.

In the Handbook of Technological Pedagogical Content Knowledge (TPCK) for Educators (2008), numerous leading researchers provide examples of the many ways in which TPCK can be applied in teaching. Different developmental levels, ranging from early childhood to adults as well as many subject areas are looked at. In theory, high levels of TPCK are possible in a wide variety of teaching tasks. However, (Mishra & Koehler, 2006) said “There is no single technological solution that applies for every teacher, every course, or every view of teaching. Quality teaching requires developing a nuanced understanding of the complex relationships between technology, content, and pedagogy, and using this understanding to develop appropriate, context-specific strategies and representations” (p. 1029).

2.6.1 Assessing teachers' TPCK

To assess the knowledge base of teachers is challenging, therefore assessing TPCK is not easy. Research to develop measures of assessing teachers' TPCK has started and is continuing. Studies in TPCK have focused on defining and measuring this teacher knowledge and its constructs. In their study, researchers such as Alev, Karal-Eyuboglu, & Yigitc (2012), focused on investigating the development of 20 fourth grade prospective physics student teachers' PCK with technology through designing teaching activities. They concluded that the activities supported student-centric learning and students took responsibility for their own learning. Kocuglu, (2009), explore how TPCK develops in pre-service English-as-a-Foreign Language (EFL) teachers who enrolled in the required Computer-Assisted Language Learning (CALL) course confirmed the course as being helpful in developing pre-service teachers' TPCK and supporting them in practicing their TPCK.

Jang & Tsai, (2012) have also undertaken a case study to identify teachers with TPCK. In their study to examine Taiwanese elementary mathematics and science teachers' TPCK with respect to current use of IWBs as well as associations between in-service teachers' TPCK and other factors, they concluded that teachers' TPCK differed significantly based on teachers' teaching experience. Teachers with more years of teaching experience demonstrated significantly higher TPCK than did teachers who had fewer years of teaching experience. Other researchers are using the TPCK framework to develop surveys to administer to pre-service teachers (Schmidt, et al., 2009) as well as serving teachers (Archambault & Crippen, 2009) assess teachers TPCK.

However, Forssell (2011), posits that there is a challenge when evaluating teacher knowledge in a survey form, which concerns how to effectively balance the details of the individual teacher's teaching task against the applicability of the survey questions to a varied range of the teachers taking part in the research as respondents. In essence, a particular technology should be identified as well as a specific subject topic at a specific cognitive level. This current study, which is focuses on a specific grade 11 topic (electricity), makes use of the survey instrument of Schmidt et al (2009) – which has been used to survey science teachers' TPCK successfully – yet has been adapted and modified for the purposes of collecting data (see section 3.3.3.1). Examples of some of the researchers who used the survey successfully to elicit teachers TPCK include (Jang, & Tsai, 2012, Mouza, Karchmer-Klein, Nandakumar, Ozden, & Hu, 2014 and Schmidt, et al., 2009). To further support the use of the TPCK framework, Kopcha et al. (2014) particularly said that TPCK has been developed to improve teachers' technology integration to enhance teaching and learners' learning. Koh, Chai, & Tsai, (2014) also buttresses this when they said TPCK is one of the technology integration frameworks that focus on effective technology integration in terms of investigating pre-service and in-service teachers' knowledge, skills, abilities, and competencies.

2.7 Summary of chapter

The chapter presented TPCK theoretical framework and literature review that is relevant to the study. The literature reviewed included: a few; epistemological issues/ current challenges for the TPCK framework, hypothetical relationship between TPCK, its constructs and learners'

achievement, learner achievement, as well as teacher factors as one of the factors affecting learner achievement. Other topics discussed in the chapter are learner achievement in their study of electricity, electricity as a high school physics topic, TPCK in the teaching context and assessing teachers' TPCK.

CHAPTER 3

RESEARCH DESIGN AND METHODS

3.1 Introduction

This chapter describes the research design, the research sample, instruments for data collection, procedure for data collection and the methods that will be used for data analyses. It also includes a discussion of methodological norms (validity and reliability issues) and ethical considerations. The research is done with teachers and their grade 11 learners on the topic electricity. The purpose of the study was to investigate physics teachers' technological and pedagogical content knowledge and their learners' achievement in their study of electricity. A hypothetical model of the interrelationship between TPCK and its constructs as well as learner achievement is presented (see section 2.4) and the research questions (see section 1.5) are related.

3.2 Research design

This study followed an explanatory mixed method research design (Creswell, 2015). The collected quantitative data and results provided a general picture of the research problem. In order to refine, or better explain the general picture, more data and its analysis is required specifically through qualitative data collection (Creswell, 2015). This design makes use of a correlational study and a survey design to address the aim of the study. This study is investigating: the relationships between physics teachers' technological pedagogical content knowledge (TPCK) and their grade 11 learners' achievement in electricity; teachers' TPCK and its relationship with its constructs, as well as teachers' demographics; teachers' technology

use and what technologies teachers with TPCK use in teaching grade 11 electricity as stated in section 1.4 and to answer the research questions (see section 1.5) of the study.

The correlational study was used to determine whether there are relationships between teachers' technological pedagogical content knowledge (TPCK), their learners' achievement, the TPCK and its constructs, and TPCK and teachers' demographics. Qualitative data was collected using a survey to support the quantitative results.

3.3 Research methods

3.3.1 Sample and participants in the study

A purposive sampling technique (Welman, Kruger & Mitchell, 2005) was employed. This sampling technique was chosen because, whilst reviewing literature, it became known that the province of Mpumalanga is mostly underperforming and has produced disappointing grade 12 matriculation results. Mpumalanga province has four regions. Table 3.1 below shows the results of the four regions from 2012 to 2016. Of the four regions, Nkangala region is the closest to the researcher. Therefore, for this study the participants comprised of 42 physical sciences teachers and their 1423 grade 11 learners in the Nkangala district of Mpumalanga.

Table 3.1: National Senior Certificate (NCS) District performance, 2012 to 2016

	2012	2013	2014	2015	2016
	% Achieved	% Achieved	% Achieved	% Achieved	% Achieved
MPUMALANGA	70.0	77.6	79.0	78.6	63.6
BOHLABELA DISTRICT	62.5	72.0	76.8	76.7	55.0
ELHLANZENI DISTRICT	74.0	82.0	82.1	82.4	64.2
GERT SIBANDE DISTRICT	69.0	76.4	77.1	72.6	68.0
NKANGALA DISTRICT	73.0	77.5	78.1	81.7	67.0

Source: National Senior Certificate Examination School Subject Report, 2015 & 2016

3.3.2 Instruments

The study employed five instruments to collect data to answer the research questions (see section 1.5). The five instruments used to collect data were:

1. Physics Teachers' Technological and Pedagogical Content Knowledge Questionnaire (PTTPCKQ)
2. Teacher Electricity Teaching Lesson Plans (TETLP)
3. Learners' Confirmation of Physics Teachers' Technological Pedagogical Content Knowledge Questionnaire (LCPTTPCKQ)
4. Learner Electricity Learning Confirmatory Questionnaire (LELCQ)
5. Learner Electricity Achievement Test (LEAT).

The descriptions and the developments of the instruments were presented (see section 3.3.3). In research question 1, there are two variables: (physics teachers' technological pedagogical content knowledge) TPCK and their learners' achievement. Physics teachers' TPCK in this study was measured with the PTTPCKQ and TETLP. Their learners' achievement was measured with the LEAT. In order to answer research question 2, the teachers' background information such as age, gender, qualifications, subject majors, and teaching experience was collected using the PTTPCKQ. To answer research 1 to 5, LCPTTPCKQ together with PTTPCKQ were used to collect data. To answer research question 6 and 7 data were collected using the TETLP and LELCQ respectively as question 6 explores the types of representations, illustrations, examples and the ways of explanations that physics teachers used when explaining concepts, or designing activities such as examples in class, class

activities, and homework in the electricity lessons. Research question 7 explores the sections of electricity in the CAPS physics syllabus that teachers are neglecting to teach.

3.3.3 Description and the development of the instruments

3.3.3.1 *Physic Teachers' Technological and Pedagogical Content Knowledge Questionnaire (PTTPCKQ)*

This is a survey questionnaire answered by participating teachers. It was developed after literature review of 'The Survey of Pre-service Teachers' Knowledge of Teaching and Technology' (developed by Schmidt, Baran, Thompson, Mishra, Koehler, Shin (2009)) had proven successful in surveying science teachers' TPCK (see section 2.6.1). It was adapted, modified (questions that were not relevant were deleted) and used for the purpose of collecting data to answer research questions 1 to 5 specifically. For example, the original questionnaire had the statements categorised under the various constructs of the TPCK. These constructs are: Technology Knowledge (TK), Content Knowledge (CK), Pedagogical Knowledge (PK), Pedagogical Content Knowledge (PCK), Technological Content Knowledge (TCK), Technological Pedagogical Knowledge (TPK) and the Technological Pedagogical Content Knowledge (TPCK). For instance, three statements (CK) were given and these three statements were repeated for various subjects including science but not physics as follows:

- I have sufficient knowledge about science.
- I can use a scientific way of thinking.
- I have various ways and strategies of developing my understanding of science.

The above three statements were modified in the PTTPCKQ questionnaire in my study as follows:

- I have sufficient knowledge about physics.
- I can use a scientific way of thinking.
- I have various ways and strategies of developing my understanding of physics.

However, under the heading TPK there were nine statements on the original questionnaire which were not modified in anyway. They were used verbatim and on the PTTPCCKQ because these statements were suitable for the current study. The nine statements appear on the PTTPCCKQ as statements 18 to 26 (see Appendix 1).

As part of the modification in my study, the PTTPCCKQ questionnaire did not have the headings; Content Knowledge (CK), Pedagogical Knowledge (PK), etc for the different categories of the statements. The headings were omitted to reduce the number of words on the questionnaire and to allow the respondents to focus only on the statements and not the headings. The structure of PTTPCCKQ is as follows: questions 1 to 5 is on TK, 6 to 8 is on CK, 9 to 15 is on PK, question 16 is on PCK, 17 is on TCK, 18 to 26 is on TPK, and question 27 is the TPCK.

The PTTPCCKQ was pilot tested as discussed (section 3.4.1.2). The questionnaire contained two parts. The first part of the questionnaire contained basic questions to provide participants' background information such as age, gender, qualifications, subject majors, and teaching experience. The second part had 27 items, which consisted of six-point Likert Scale questions used to elicit teachers' TPCK. In addition, under each question, spaces were provided that allowed teachers to elaborate on the choices they made on the Likert Scale, as the Likert Scale

questionnaire is a structured, close-ended questionnaire. This was chosen over the open-ended type of questionnaire for the following reasons:

- To avoid unclear or useless responses that open responses may produce.
- To avoid the difficulty of scoring open-ended questions or what is usually referred to as free response questions (Gay & Airasian, 2003). The instrument is attached in Appendix 1.

3.3.3.2 *Teachers' Electricity Teaching Lesson Plans (TETLP)*

Mathers, Oliva & Laine (2008) mention lesson plans, (among) learners' performance, learners' evaluation of the teachers' teaching, peer evaluation of teacher, classroom observations, self-evaluation, and learners' work-sample analyses as a few teachers' teaching evaluation tools. Many educational studies conducted by researchers such as (Prescott, Bausch, & Bruder, 2013; Sahin, 2012; Han & Shin, 2011; Donmez, & Basturk, 2010; Wong & Lai, 2006; and Webb & Cox, 2004) also utilised teachers lesson plans as teaching evaluation tools. Therefore, participating teachers' lesson plans for electricity lessons – referred to as Teachers Electric Teaching Lesson Plans (TETLP) – were collected as data and analysed to help answer research question 6 in particular (see section 1.5 for research question 6).

3.3.3.3 *Learners' Confirmation of Physic Teachers' Technological and Pedagogical Content Knowledge Questionnaire (LCPTTPCKQ)*

Learners can be used to evaluate their teachers' teaching (see section 3.3.3.2). This suggests that learners can then confirm if topics were taught to them and how the teaching was

presented. Therefore, the LCPTTPCKQ was developed by adapting the PTTTPCKQ from (Schmidt, et al, 2009). The questionnaire also contains two parts, like the PTTTPCKQ. The first part of the questionnaire contains basic statements to obtain learners' background information such as the learner code (learner name), school code (the name of the school), learner age and gender. The second part consists of six-point Likert Scale statements similar to that of the second part of the PTTTPCKQ. The statements in the LCPTTPCKQ were employed to elicit learners' confirmation or rejection of their teachers' response in the PTTTPCKQ as well as to address their use of technology in teaching electricity. However, some items were deemed inappropriate for learners to respond to and were removed from the learners' questionnaire. Statements 1, 2, 5, 8, 14, 20, 21, 22, 24, and 25 on the PTTTPCKQ were not included for the learners on the LCPTTPCKQ. These statements are as follows:

- I know how to solve my own technical problems
- I can learn technology easily
- I have the technical skills I need to use technology
- I have various ways and strategies of developing my understanding of physics
- I am familiar with common student understandings and misconceptions
- My teacher education program has caused me to think more deeply about how technology could influence the teaching approaches I use in my classroom
- I am thinking critically about how to use technology in my classroom
- I can adapt the use of the technologies that I am learning about to different teaching activities
- I can use strategies that combine content, technologies and teaching approaches that I learned about in my coursework in my classroom and
- I can provide leadership in helping others to coordinate the use of content, technologies and teaching approaches at my school.

A careful look at these statements shows that learners could not provide correct answers to these statements on their teachers' behalf. Hence, these statements were not on the LCPTTPCKQ. The second part of the LCPTTPCKQ has only 17 items instead of the 27 for their teachers. Further clarification is presented on how the PTPCKQ is modified for the learners (see table 3.2). The statements on the PTPCKQ are placed alongside its modified version on the LCPTTPCKQ. The LCPTTPCKQ instrument is attached in Appendix 2.

Table 3.2: Statements on the PTPCKQ alongside its modified version on the LCPTTPCKQ

No.	PTPCKQ	No.	LCPTTPCKQ
3	I frequently play around with the technology.	1	My physics teacher keeps up with important new technologies.
4	I know about a lot of different technologies.	2	My physics teacher knows about a lot of different technologies.
6	I have sufficient knowledge about physics.	3	My physics teacher has sufficient knowledge of physics.
7	I can use a scientific way of thinking.	4	My physics teacher is able to apply scientific ways of thinking during his/her teaching.
10	I can adapt my teaching based-upon what students currently understand or do not understand.	5	My physics teacher develops lesson using our previous knowledge on the topic.
9	I know how to assess student performance in a classroom. Give examples	6	My physics teacher assesses our performance after lessons.
11	I can adapt my teaching style to different learners.	7	My physics teacher uses different teaching styles to accommodate different learners.
12	I can assess student learning in multiple ways. Give examples	8	My physics teacher gives different forms of assessment such as class work, homework, project and research work.
13	I can use a wide range of teaching approaches in a classroom setting.	9	My physics teacher uses a wide range(variety) of teaching approaches such as lecturing, group discussion, practical's question and answers, to teach.
15	I know how to organise and maintain classroom management.	10	My physics teacher's classroom is well organised and well managed.

Table 3.2: continued

No	PTTPCKQ	No	LCPTTPCKQ
16	I can select effective teaching approaches to guide student thinking and learning physics.	11	My physics teacher's teaching approaches are effective and that guides me in learning physics.
17	I know about technologies that I can use for understanding and doing physics.	12	My physics teacher chooses technologies that enhance my learning of physics.
18	I can choose technologies that enhance the teaching approaches for a lesson.	13	My physics teacher chooses technologies that enhance his/her teaching approaches.
19	I can choose technologies that enhance learners' learning for a lesson.	14	My physics teacher uses technologies to teach which enhances better understanding of various concepts in physics.
23	I can select technologies to use in my classroom that enhance what I teach, how I teach and what students learn.	15	My physics teacher selects technologies which enhances what he/she teaches, how he/she teaches and what I learn.
26	I can choose technologies that enhance the content for a lesson.	16	My physics teacher chooses technologies that bring out the main content of a lesson.
27	I can teach physics lessons that appropriately combine technologies and teaching approaches.	17	My physics teacher teaches lessons that appropriately combine physics, technologies and teaching approaches.

3.3.3.4 *Learner Electricity Learning Confirmatory Questionnaire (LELCQ)*

Anderson, (2004) said that for researchers to test learners, by researchers using tests not set by the learners' teacher, to evaluate the teachers' teaching, researchers must provide learners the opportunity to confirm whether they were taught the topics they will be tested on or not. This, Anderson, (2014) referred to as estimates of opportunity offered to learners for them to learn. If the estimates are low, it is suggested that efforts must be made to increase learners' opportunity to learn before they are tested. The researcher who was not the teacher of the participating learners (see section 3.3.3.5) developed the LEAT. Therefore, it is necessary to use the LELCQ to confirm or estimate the opportunity to learn presented to

the learners before they write the LEAT. This survey questionnaire was developed by using structured, close-ended questions and learners responded by indicating yes or no to 21 questions. The questions were asked to elicit learners' views as to whether the 21 subsections of the topic electricity were taught to them by their teachers (see Appendix 3). In addition, this questionnaire was developed to answer research question 7. The learners' opportunity to learn was assessed using the LELCQ. The average yes responses from the LELCQ were calculated for each participating school. The participating schools with an average percentage yes score less than 75% were eliminated from the list of participating schools as they were considered have low estimates of opportunity to learn.

3.3.3.5 *Learner Electricity Achievement Test. (LEAT)*

The LEAT test was used to obtain data about learners' achievements in their study of electricity. The test was constructed by the researcher, taking into consideration the requirements stipulated by the new Curriculum and Assessment Policy Statements (CAPS) document (DoBE, 2011). In addition, the South African past matriculation physical sciences (physics) examination papers and commonly used South African physical science textbooks were some of the resources used to construct the LEAT (see Appendix 4).

For a test to be used to make inference on learners' achievement reliably, the test should be aligned with curriculum standards that the students are expected to be taught. There is the need to check whether there is a demonstrable relationship between the content specifications intended to be evaluated on the test (Darling-Hammond, Herman, Pellegrino, et al. 2013).



Therefore, to ensure that the test items are aligned with the curriculum requirements, the content, concepts and skills required for the study of grade 11 electricity were identified using the CAPS document (DoBE, 2011a) as well as the previous knowledge required from grade 10 electricity according to CAPS (DoBE, 2011a). Questions were selected from these sources as mentioned above and were validated using a validation instrument adopted and modified from (Ogbonnaya, 2011) (see Appendix 5). The process of validation and piloting is discussed further (see section 3.4.1.1).

3.4 Methodological norms (validity and reliability issues)

3.4.1 Validity of the instruments

An instrument is valid when it satisfactorily measures what it is estimated to measure. There are four types of validity in research. These are: construct, content, face and criterion validity (Welman, Kruger & Mitchell, 2005). Construct validity refers to the consistency between the instrument and accepted concepts connected to the topics being studied. Content validity refers to the extent to which the instrument measures a representative sample of the topics treated. Face validity determines whether the instrument appears appropriate to those who will complete it. Content, construct, and face validities of the instruments in this study were established and discussed in sections below.

3.4.1.1 Validity of the Learner Electricity Achievement Test (LEAT)

The researcher constructed the LEAT questionnaire. To ensure that the questionnaire adequately covers the concepts in electricity, the researcher used the new South African

Curriculum and Assessment Policy Statement (CAPS) on physical science (DoBE, 2011a). The approved CAPS physical science textbooks (found on the Department of Basic Education textbooks catalogue) alongside past South African matriculation physical sciences (physics) examination papers were used. This was to ensure the instrument is consistent with accepted concepts connected to the topics expected to be studied. The questionnaire was given to three experienced Heads of Department (HODs) of physical sciences in secondary schools and two physical science subject facilitators to validate if the questionnaire covered the content of electricity in grade 11 in the new South African curriculum, and if the questions were within the scope of grade 11 learners. These validators were to validate the LEAT test using a validation instrument adopted and modified from (Ogbonnaya, 2011) (see Appendix 5).

The validation instrument required the validators to indicate the cognitive levels of the questions as well as justify them using the guidelines in the CAPS curriculum statement. They had to indicate why they gave a particular question a particular cognitive level. Using the guidelines in CAPS, the validators agreed on the content appropriateness of the test as well as the cognitive levels of the questions (see appendix 5). The test was then piloted with a grade 12 class of 53 learners since they had been taught electric circuits in grade 11. The pilot class wrote the test twice over two weeks. The marks were used to calculate the reliability (see section 3.4.2.1).

3.4.1.2 *Validity of the Physics Teachers' Technological and Pedagogical Content Knowledge Questionnaire (PTTPCKQ)*

This instrument was given to five physical sciences teachers for vetting. They vetted the instrument to ascertain whether the items in the instrument relates to what they were meant to measure and whether the language is appropriate for the relevant respondents. They were only requested to respond to the items and make notes on the questionnaire of items on the questionnaire that they may like clarity on.

These minimal validating procedures were taken as Schmidt, et al. (2009) had detailed the steps they used to develop and validate this framework to measure pre-service teachers' development of TPACK. Also, Lin, et al (2012) performed rigorous statistical analysis to confirm the validity of this framework and concluded that "The identified TPCK model is consistent with Mishra and Koehler's model (2006), encompassing seven factors including TK, PK, CK, TCK, TPK, PCK, and TPCK. Such a model of science teachers' TPACK is distinguishable from those identified in previous studies of teachers with diverse academic backgrounds. It is also proved that science teachers' perceptions of synthesized knowledge of technology, pedagogy, and content are significantly correlated with their notions of technological content knowledge, technological pedagogical knowledge, technological knowledge, content knowledge, pedagogical knowledge, along with pedagogical content knowledge. These findings may, hence, provide a robust theoretical basis for representing science teachers' TPACK" (p. 10).

Lee and Tsai, (2010); Archambault, & Barnett, 2010; Koh, Chai & Tsai, (2010), and Sahin, (2011) are among researchers who also validated the model. Chai, Koh, & Tsai, (2013) in their study titled, 'A Review of Technological Pedagogical Content Knowledge,' reported a significant progressive increase in the usage of the framework by researchers in various study from 2003 till 2010.

With the above reported efforts by many researchers to validate the TPCK model, the PTTPCCKQ which is adapted from it, was deemed to be valid.

3.4.1.3 *Validity of the Learners' Confirmation of Physics Teachers' Technological and Pedagogical Content Knowledge Questionnaire (LCPTTPCKQ)*

As mentioned, (see section 3.3.3.3) the LCPTTPCKQ is similar to the PTTPCCKQ. Therefore, the validity was established as discussed in section 3.3.3.3. However, due to its modification to enable learners to respond to it, the instrument was given to five physical teachers and 53 physical learners for vetting. They vetted the instruments to ascertain whether the items in the instruments relate to what they were meant to measure and whether the language is appropriate for the learner respondents. They were simply requested to respond to the items and make notes on the questionnaire of items on the questionnaire that they may like clarity on. There were no complaints from either the five teachers or the 53 learners.

3.4.1.4 *Validity of the Learner Electricity Learning Confirmatory Questionnaire (LELCQ)*

As mentioned, (see section 3.3.3.4), this questionnaire was constructed by the researcher and therefore has to be validated too. The questionnaire was given to the three experienced

Heads of Department (HODs) of physical sciences in secondary schools and two physical sciences subject facilitators (see section 3.4.4.1) to validate whether the questionnaire covered the content of electricity taught in grade 11 in the new South African CAPS curriculum. These validators were to validate the LELCQ using a validation instrument (see Appendix 5). The validation instrument required the validators to indicate by ticking 'yes' or 'no' in column 2 whether the topics listed in column 1 correspond with the topics educators are required to teach grade 11 learners according to the CAPS curriculum. The validators unanimously ticked yes to all 21 items in the questionnaire as the required topics for grade 11 electricity. The LELCQ was also then piloted.

3.4.2 Reliability of instruments

3.4.2.1 *Reliability of the Learner Electricity Achievement Test (LEAT)*

Reliability tells test users about the consistency of the scores produced in a test, while the validity tells test users about the appropriateness of a test. Both are therefore important for judging the suitability of a test or measuring instruments (Gay & Airasian, 2003: p. 141). However, (Gay & Airasian, 2003: p. 141) argue "a valid test is always reliable, but a reliable test is not always valid". For this reason, the reliability of the LEAT was established after the validity considerations, using the Spearman-Brown formula. For this purpose, the test was given to a pilot sample of 53 physical science learners who at the time were in grade 12 for testing. The pilot sample wrote the test twice within two weeks.

The marks obtained (Appendix 6) were used to calculate the Spearman correlation coefficient using SPSS version 23. The marks yielded a Spearman correlation coefficient of 0.73. Appendix 7 shows a detailed table of the SPSS results of the calculation of the Spearman correlation

coefficient. This was then used in the Spearman-Brown Formula $R = 2r / (1 + r)$, to determine the reliability of the test instrument. The Spearman-Brown formula yielded a reliability coefficient of 0.84. The interpretation of this coefficient of reliability follows from the fact that reliability is the degree to which a test consistently measures whatever it measures. The reliability of the LEAT was established as 0.84 using the Spearman-Brown formula. Reliability is usually expressed numerically ranging from 0.0 to 1.0; so that a high coefficient indicates high reliability. In this case, a reliability of 0.84 is very high and the test is deemed to be reliable.

3.4.2.2 *Reliability of the PTPCKQ, LCPTTPCKQ and LELCQ*

As discussed earlier (see section 3.4.1.2 to 3.4.1.4), the validity and reliability of the TPACK framework was done by many researchers. Yet even though the PTPCKQ and the LCPTTPCKQ were adapted from the TPACK, the reliability of these two instruments as well as the LELCQ were determined using SPSS to calculate coefficient alpha (α) (Blumberg, Cooper, Schindler, 2008). The reliabilities were determined by using SPSS to calculate coefficient alpha (α) as follows: PTPCKQ = 0.93, LCPTTPCKQ = 0.89, and LELCQ = 0.86. These reliabilities are shown in Appendix 8. As indicated above, a high coefficient alpha indicates high reliability.

3.5 Research Procedures

The study begins with a thorough review of literature on the topic under consideration in order to conduct a detailed enquiry into the research that has already been done in this field of research. From this literature, the instruments (see section 3.3.2) were developed and used

to collect data to answer the research questions stated (see section 1.5). The validity and reliability of these instruments were then pursued according to laid down principles. These validity and reliability issues were discussed in detail (see section 3.4). Piloting of the data collecting instruments was then conducted to correct shortcomings which become real only when the instruments have been tested. The researcher applied and obtained ethical clearance from the relevant stakeholders (see section 3.7). According to the CAPS document, electricity should be taught in schools throughout the country between July and August, which is in the third quarter of the school's calendar. With the participants' consent attained, already before the teaching of electricity, the data collection stage of the research was then implemented. This research procedure is depicted diagrammatically in figure 3 below.

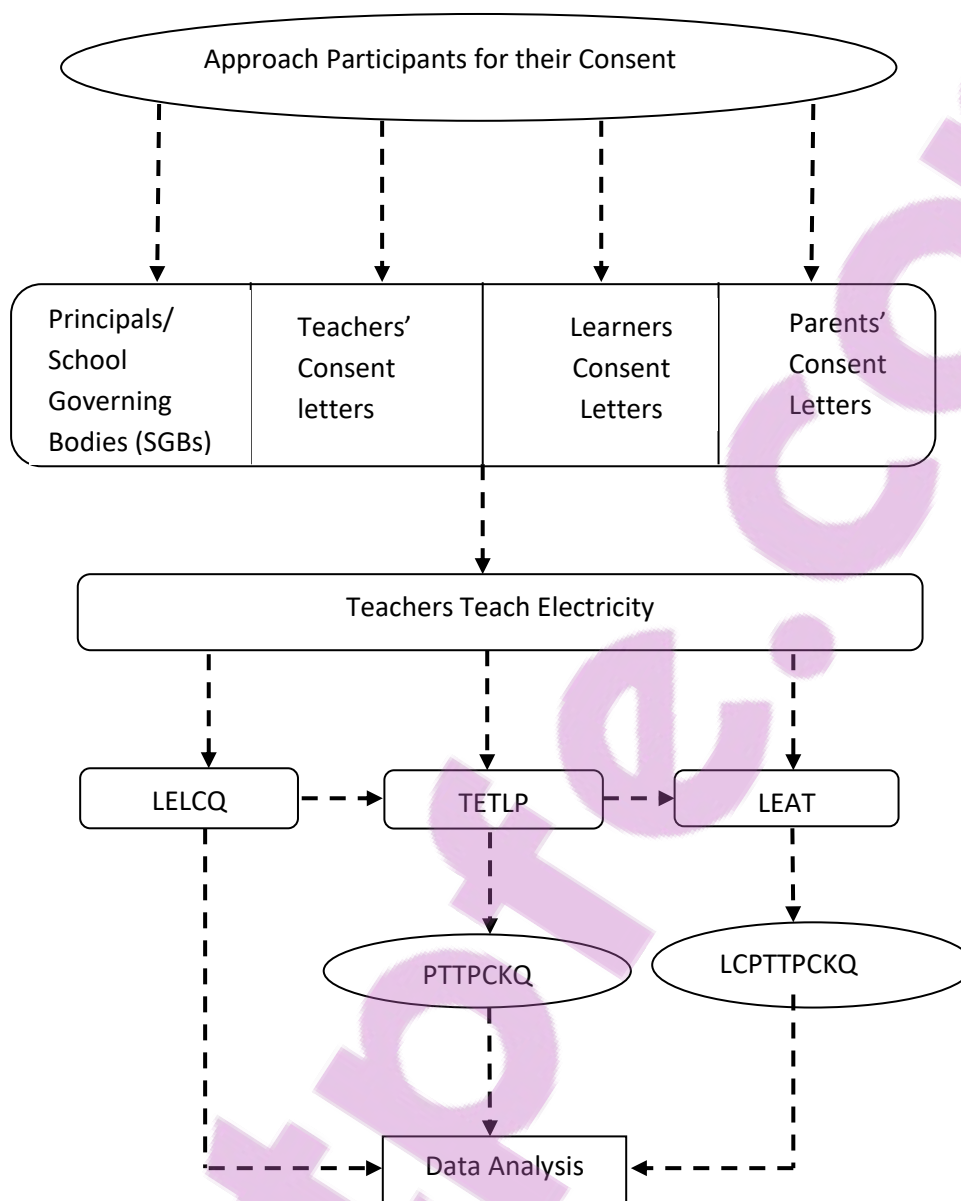

Figure 3: Research procedure.

3.6 Data analysis

3.6.1 Quantitative data analysis

Quantitative data gathered was analysed using descriptive and inferential statistics in a correlational study and survey design. Spearman's correlation coefficient (two-tailed) was calculated using SPSS at 95 % confidence interval between physics teachers' TPCK and their

learners' achievement, physics teachers TPCK and their demographics, physics teachers TPCK and the six constructs of the TPCK from the teachers' own perspective, as well as Physics teachers TPCK and the six constructs from their learners' perspective. A t-test was also calculated using SPSS to compare the means of the responses of the teachers and the learners on the constructs of the TPCK. A summary of the data analysis showing the instruments used in the study and the research questions they answer is shown (see table 3.3). Details of these quantitative data analyses carried out in this study are described in section 4.2.

3.6.2 Qualitative data analysis

The qualitative data collected from Physics Teachers' Electricity Teaching Lesson Plan (TETLP) was analysed using document analysis. The Learner Electricity Learning Confirmatory Questionnaire (LELCQ) was also analysed qualitatively. A summary of the data analysis showing the TETLP and LELCQ instruments to answer research questions 6 and 7 used in the study is as shown in table 3.3 below. Detailed explanation of the qualitative data analysis of this study is given in section 4.2.4

Table 3.3: A summary of data analysis showing the instruments used in the study

RESEARCH QUESTIONS	INSTRUMENTS	ANALYSIS
Q1 Q2 Q3	PTTPCKQ LEAT	Each teachers' responses on PTTPCKQ was recorded and coded in SPSS. Each teachers' learners' average marks on the LEAT were calculated. The responses on the PTTPCKQ and the average LEAT marks were correlated to answer Q1. Teachers' TPCK from PTTPCKQ were correlated with their demographics to answer Q2 from teachers' perspective and the TPCK were correlated with its six constructs to answer Q3 from learners' perspective.
Q4	LCPTTPCKQ	Each learner response on the LCPTTPCKQ was documented per question per school and the mode of the responses were taken as the school's response to that question. This was done for all the TPCK constructs. Then the constructs were correlated with the TPCK to answer Q4.
Q5	PTTPCKQ & LCPTTPCKQ	t-Test analysis was performed using SPSS to compare the means of the responses of the teachers and the learners on the constructs of the two questionnaires. This was to see if there was (a) collaboration between the teachers and their learners, and to enable us to answer Q5.
Q6	TETLP	The lesson plans of the teachers who reported to have TPCK on the PTTPCKQ, were selected. These lesson plans were analysed qualitatively to see what technologies they used in their electricity lessons.
Q7	LELCQ	The 'yes' and 'no' responses on the LELCQ were tallied. Percentage 'yes' was calculated for each schools' 'yes' responses and used as an opportunity to learn offered to the learners. Then the 'no' responses were counted for each of the 21 sections of electricity according to the CAPS syllabus. Percentages of these were calculated in Excel to determine the sections that were neglected by the teachers.

3.7 Ethical considerations

The researcher applied and received ethical clearance from the Ethics Review Committee of the University of South Africa (see Appendix 9), after receiving ethics approval from the

Mpumalanga Department of Education granting permission to conduct research in their schools in the Nkangala region of the province (See Appendix 10). These are requirements before any research can be carried out in the University of South Africa and in the Mpumalanga Department of Education. This is to ensure that the research conducted by the students of the University of South Africa complies with the protection of the rights of the subjects as well as to ensure that due process is followed. Also, as the principals, teachers and learners and their parents are required to give consent in any research, particularly where minors in schools are involved, their informed consent was sought in writing before the data collection stage of the study was implemented. These letters as well as the consent forms can be found in Appendices 11, 12, 13 and 14.

Since the participants are very instrumental to the success or failure of any research, the researcher believes that he has a particular responsibility to the teachers and learners as subjects of the study. One of the responsibilities of the researcher to the participants in this study is to ensure that they are protected from any victimisation, information distortions or any other forms of practices that may infringe on their rights as participants in the study. The researcher was guided by the fact that participants in a research study have the right to be informed about the aims, purposes and likely publication of findings of the research and to give their informed consent before participating in the research. For this reason, the researcher met with the selected teachers and the learners involved in the study and explained what was required of them in the research. It was also emphasised to them that participation in the study is voluntary and that nobody will be victimised in any way – as was stated in their ethics letter. They were also informed in the letter that they could also withdraw from the research if they wanted to.

3.8 Summary of chapter

The chapter described the research design, the methodology used in carrying out the study and the participants in the study. It outlined the instruments used, described the instruments, how the instruments were constructed, and the validity and reliability of the instruments was also discussed. Furthermore, the chapter reported on the pilot study and the ethical procedures followed. The data collected, and analysis will be discussed in the following chapter in order to answer the research questions.

CHAPTER 4

RESULTS

4.1 Introduction

The aim of this chapter is to present the results in the form of data analyses of the research conducted to enable the provision of answers to the research questions that guided the study. To investigate the relationship between the teachers' TPCK and their learners' achievement, the following analyses were done: Teachers' knowledge in each of the constructs of TPCK were analysed. From the results of the analyses, the teachers were grouped according to the level of their TPCK. As hypothesised in figure 2, Learners were grouped according to the TPCK of their teachers. Achievements of individual teachers' grouped learners were averaged and compared with their teachers' TPCK and a determination of the relationship between the teachers' TPCK and their learners' achievements were made in the correlational analysis (see section 4.2.2). Other correlational analysis to answer research questions 2 and 3 are also discussed (see section 4.2.2).

Also, a comparison between the teachers' responses on the PTTCKQ and the learners' responses on the LCPTTPCKQ of the seven constructs of the TPCK framework (TK, CK, PK, PCK, TCK, TPK, and TPCK) were made using the independent sample t-Test as in figure 4, 5, 6 and 7 and further discussed in section 4.2.3. Figure 4 is a representation of how the constructs of the TPCK from the teacher and the learner questionnaire compare in terms of correlation with the TPCK. Figures 5 represents the relationship between the teachers' responses to the PTTCKQ on the six TPCK constructs and TPCK and figure 6 represents same but according to

learners from the LCPTTPCKQ. Figure 7 then represents a comparison of these responses from the PTPCKQ and LCPTTPCKQ using t-test.

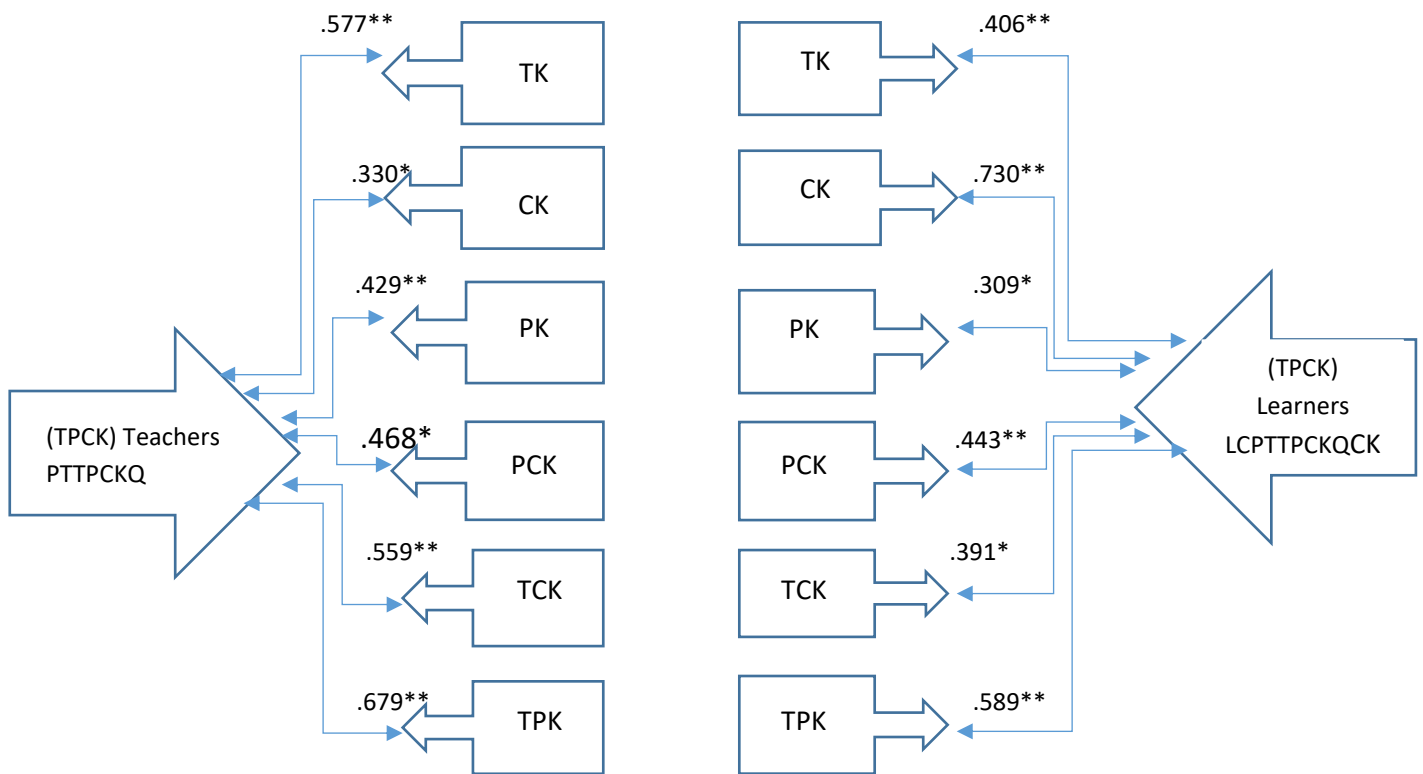

Figure 4: Comparison of the teachers' responses on the PTPCKQ and the learners' responses on the LCPTTPCKQ of the constructs of the TPCK framework showing the correlations between the TPCK with its constructs (see section 4.2.2.4 and 4.2.2.5).

4.2 Quantitative data analysis

4.2.1 Descriptive statistical analysis of physics teachers' demographic data

The teachers' demographic information regarding their qualifications, subject specialisation and years of teaching experience is shown in table 4.1. The table shows that most of the physical sciences teachers who took part in the study were male. They form 90% of the sample. It also shows that approximately 93% of the teachers majored in physical sciences

and about 71% of them had taught for over 5 years, that is 33% of them taught for over 10 years but 29% of them taught for between 0 to 5years. The teachers (52%) are older than 40years, 21% of them are between 36 to 40years old, 14% are between 26 to 30years and 12% are between 31 to 35years of age. Of the 42 participating teachers, only 11 (26%) had diplomas, the rest 31 (74%) having higher degrees.

Table 4. 1: Teachers' Demographic data (N = 42)

Gender	Number
Male	38
Female	4
Age Range	
20 – 25	0
26 – 30	6
31 – 35	5
36 – 40	9
41 +	22
Teaching Experience	
0 - 5 Years	12
6 - 10 Years	9
11 - 15 Years	14
16 - 20 Years	3
Over 20 Years	4
Teachers' Qualifications	
Teachers' certificate	0
ACE	0
Diploma	11
Higher Diploma	3
Bachelor's degree	15
Honours Degree	10
Master's Degree	3
Physical Sciences Major	
Yes	39
No	3

4.2.2 Correlation Analysis

Correlation analysis was used to ascertain if there is any relationship between physics teachers' TPCK and their learners' achievement in the topic electricity. The participating teachers' score on question 27 of the Physics Teachers' Technological and Pedagogical Content Knowledge Questionnaire (PTTPCKQ) was used as teachers own reported (TPCK) while learners' achievement was measured using the learners' scores on the learners' test, referred to as Learner Electricity Achievement Test (LEAT).

The average LEAT score of the learners of each teacher was used as the measure of the teacher's learners' achievement. The PTTPCKQ instrument for the teachers' self-evaluation was a Likert Scale type questionnaire, which is an interval scale. Hence, Spearman's correlation was used to determine the appropriate coefficients as indicated in table 4.2 below.

Spearman's correlation coefficient between physics teachers' technological and pedagogical content knowledge and the measure of their learners' achievements were calculated using SPSS at 95% confidence interval. The correlation result being significant at $p < 0.05$ means that the probability of obtaining the correlation by chance is less than five out of 100 (5%).

4.2.2.1 Correlation between Physics Teachers Technological and Pedagogical Content Knowledge, experience, qualifications and their learners' achievement

Table 4.2 shows the correlation matrix of Spearman's correlation between physics teachers' technological and pedagogical content knowledge, their qualifications, their learners' average marks and their experiences. The table shows that there were positive relationships between physics teachers' experience and their learners' achievements as well as physics teachers' TPCK and their qualifications. There was also a positive statistical relationship between physics teachers' TPCK and their learners' achievement. However, the correlations between the physics teachers' TPCK and their learners' achievement was not statistically significant, but the correlation between physics teachers' experience and (their) learners' achievement as well as physics teachers' TPCK and their qualifications, were found to be statistically significant.

Table 4. 2: Spearman correlation between physics teachers' TPCK, Experience, Qualifications and Average Learner Mark/ Achievement

Variables	Physics Teachers' Experience	Average Learner Mark	Physics Teachers' Qualifications	Physics Teachers' TPCK
Physics Teachers' Experience	1			
Average Learner Mark	.390*	1		
Physics Teachers' Qualifications	-.010	-.003	1	
Physics Teachers' TPCK	-.134	.280	.334*	1

*. Correlation is significant at the 0.05 level (2-tailed).

4.2.2.2 *Correlation between physics Teachers' Technological Pedagogical Content Knowledge and physics teachers' gender*

The chi-square test was used as it is a statistical test to compare observed data with the expected data to determine relationships. The chi-square test is intended to test the likelihood that an observed distribution is due to chance or not due to chance under an assumption of independence between the two variables (physics Teachers' Technological Pedagogical Content Knowledge and physics teachers' gender). The chi-square table gives the p -value. If the p -value is less than 0.05, then a statistically significant association exists between different categories of data. This means that the results cannot be attributed to chance and that a real association exists between the variables. The chi-square value gives information on whether the association is significant or not, but it does not give information on how strong or weak the association is. If the chi-square test shows significant association, then the phi test is performed for a 2X2 data table and Cramer's V test is performed for bigger data table than a 2X2. Table 4.3 below shows the cross-tabulation table of physics teachers' gender combined with physics teachers' TPCK. The observed count and the expected counts in the table are different therefore the chi-square test in table 4.4 below was used to determine if they are different enough for the association to be deemed significant. Expected counts are the projected frequencies in each cell if there is no association between the variables. Then the expected counts will be contrast with the observed counts, cell by cell. The more the difference, the higher the resultant statistics.

Table 4.3: The cross-tabulation table of physics teachers' gender combined with teachers' TPCK

		TPCK					Total	
		Strongly Disagree	Disagree	Slightly Disagree	Slightly Agree	Agree		Strongly Agree
Gender Male	Count	1	4	5	12	12	4	38
	Expected Count	.9	3.6	4.5	12.7	11.8	4.5	38.0
Female	Count	0	0	0	2	1	1	4
	Expected Count	.1	.4	.5	1.3	1.2	.5	4.0
Total	Count	1	4	5	14	13	5	42
	Expected Count	1.0	4.0	5.0	14.0	13.0	5.0	42.0

The Pearson chi-square test of independence was performed to examine the relation between physics teachers' Technological Pedagogical Content Knowledge (TPCK) and physics teachers' gender (see table 4.4). The relation between these variables was not significant; $\chi^2(5, N = 42) = 2.879, p = .719$. This implies that there is no relationship between physics teachers' gender and their TPCK. It can be seen below table 4.4 that (a. 10 cells 83.3% have expected count of less than 5. The minimum expected count is .10) This 83.3% should have been 20% or less. As it is more than the 20% the assumptions for the chi-square test is violated and hence, we use the Likelihood Ratio values and not the Pearson chi-square values.

Table 4.4: Chi-Square Tests of physics teachers' gender combined with teachers' TPCK

	Value	df	Asymp. Sig. (2-sided)
Pearson Chi-Square	2.109 ^a	5	.834
Likelihood Ratio	2.879	5	.719
Linear-by-Linear Association	.998	1	.318
N of Valid Cases	42		

a. 10 cells (83.3%) have expected count less than 5. The minimum expected count is .10.

4.2.2.3 *Correlation between physics teachers' Technological Pedagogical Content Knowledge and physics teachers' age*

Tables 4.5 and 4.6 below are similar to tables 4.3 and 4.4 under section 4.2.2.2 above, hence the analysis under this section will be similar to that of section 4.2.2.2. The observed count and the expected counts are also different in table 4.5 as it was in table 4.4, therefore the chi-square test in table 4.6 below was used to determine if they differ enough for the association to be deemed significant.

Table 4:5: The cross tabulation of physics teachers' age combined with teachers' TPCK

			TPCK					Total	
			Strongly Disagree	Disagree	Slightly Disagree	Slightly Agree	Agree		Strongly Agree
Age	26 - 30	Count	0	1	0	1	3	1	6
		Expected Count	.1	.6	.7	2.0	1.9	.7	6.0
	31 - 35	Count	0	0	0	5	0	0	5
		Expected Count	.1	.5	.6	1.7	1.5	.6	5.0
	36 - 40	Count	0	1	1	3	3	1	9
		Expected Count	.2	.9	1.1	3.0	2.8	1.1	9.0
	40 +	Count	1	2	4	5	7	3	22
		Expected Count	.5	2.1	2.6	7.3	6.8	2.6	22.0
Total		Count	1	4	5	14	13	5	42
		Expected Count	1.0	4.0	5.0	14.0	13.0	5.0	42.0

As evident in table 4.6 below, the relation between these variables was not significant; $\chi^2(15, N = 42) = 16.613, p = .343$. This implies that there was no relationship between physics teachers' age and their TPCK. It can be seen below the table 4.6 that (a. 22 cells 91.7% have expected count less than 5. The minimum expected count is .12). This 91.7% should have been 20% or less. As it is more than the 20% the assumptions for the chi-square test is again violated and hence, we use the Likelihood Ratio values from the table below and not the Pearson chi-square values.

Table 4.6: Chi-Square tests of physics teachers' age combined with teachers' TPCK

	Value	df	Asymptotic Significance (2-sided)
Pearson Chi-Square	14.729 ^a	15	.471
Likelihood Ratio	16.613	15	.343
Linear-by-Linear Association	.307	1	.579
N of Valid Cases	42		

a. 22 cells (91.7%) have expected count less than 5. The minimum expected count is .12.

4.2.2.4 *Correlation between physics teachers' TK, CK, PK, TCK, PCK, TPK and physics teachers' TPCK from the teachers' responses on the PTTPCCKQ Questionnaire.*

Figure 5 diagrammatically represents Correlations between physics teachers' TPCK constructs and physics teachers' TPCK from the teachers' responses on the PTTPCCKQ Questionnaire. Table 4.7 shows the correlation matrix of Spearman's correlation between physics teachers' Technological Knowledge(TK), Content Knowledge(CK), Pedagogical Knowledge(PK), Technological Content Knowledge(TCK), Pedagogical Content Knowledge(PCK), and Technological Pedagogical Knowledge(TPK) against their technological and pedagogical content knowledge (TPCK). The table shows that there were positive statistically significant relationships between all the constructs of the physics teachers' TPCK and their TPCK. The TPCK constructs with the highest positive statistically significant correlations with the TPCK are TPK at .679 followed by TK at .577, TCK at .559, PCK at .468 and PK at .429; all at 0.01 significant level. Then the CK is also positive statistically significantly correlated with the TPCK but with the least correlation value of .330 at 0.05 significant level.

Table 4.7: Spearman correlation between physics teachers' TK, TPK, TCK, PK, PCK, CK and TPCK from the teachers' responses on the PTPCKQ Questionnaire

Variables	Physics Teachers TK	Physics Teachers TPK	Physics Teachers TCK	Physics Teachers PK	Physics Teachers PCK	Physics Teachers CK
Physics Teachers' TPCK	.577**	.679**	.559**	.429**	.468**	.330*

*. Correlation is significant at the 0.05 level (2-tailed).

**. Correlation is significant at the 0.01 level (2-tailed).

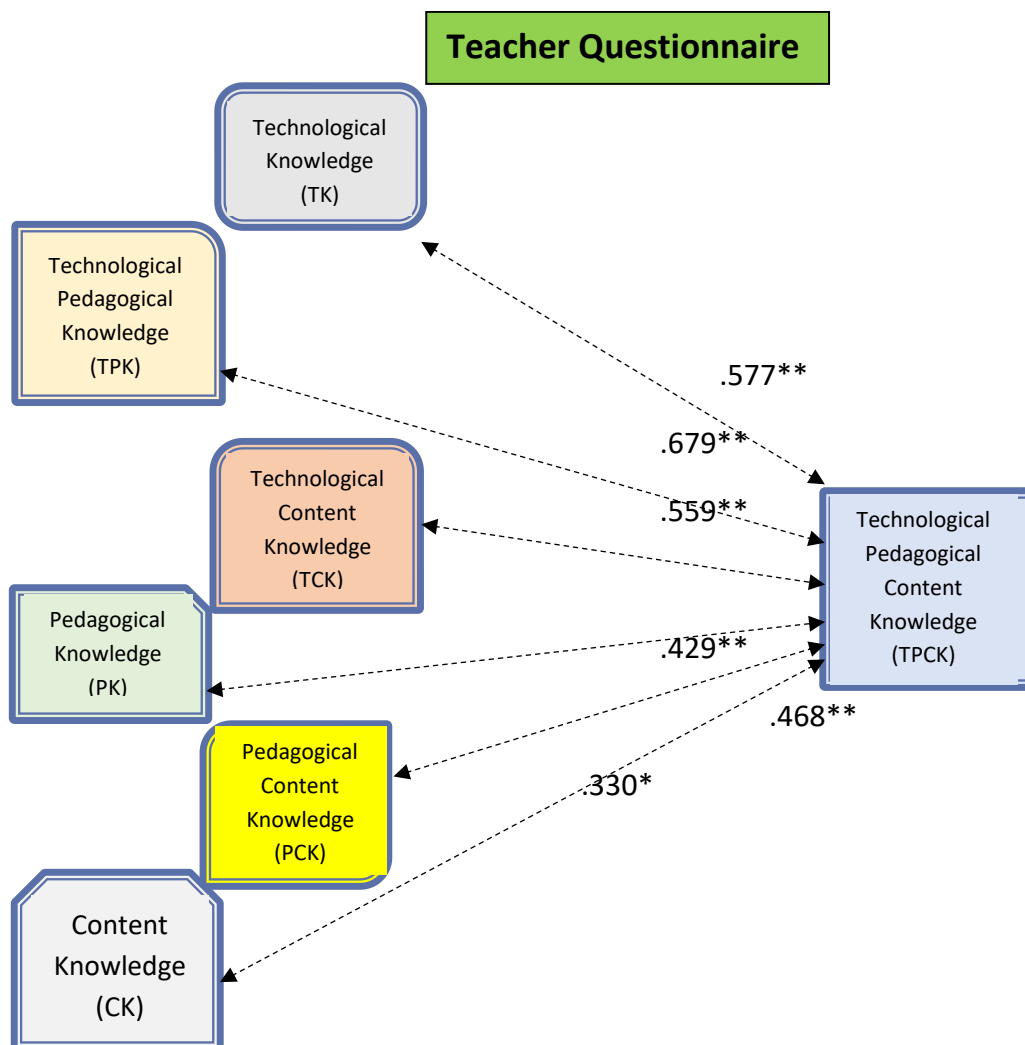

Figure 5: The relationship between the teachers' responses to the PTPCKQ on the six TPCK constructs and TPCK.

Figure 5 above further provides a clear diagrammatical view of these correlations. In the figure, the six TPCK constructs on the left are linked with the TPCK on the right with dotted lines. The correlation coefficients are then written on the dotted lines.

4.2.2.5 *Correlation between physics teachers' TK, CK, PK, TCK, PCK, TPK and physics teachers' TPCK from the learners' responses on the LCTTPCKQ Questionnaire*

Figure 6 provides a clear diagrammatical view of these correlations. Table 4.8 shows the correlation matrix of Spearman's correlation according the learners' responses on the LCTTPCKQ Questionnaire between their physics teachers' Technological Knowledge(TK), Content Knowledge(CK), Pedagogical Knowledge(PK), Technological Content Knowledge(TCK), Pedagogical Content Knowledge(PCK), and Technological Pedagogical Knowledge(TPK) against their Technological and Pedagogical Content Knowledge (TPCK). The table shows that there were positive statistically significant relationships between all the constructs of the physics teachers' TPCK and their TPCK in the learners' view. The TPCK constructs with the highest positive statistically significant correlations with the TPCK are CK at .730 followed by TPK at .589, PCK at .448, and TK at .406, all at 0.01 significant level. TCK and PK are also positive statistically significant but with the least correlation coefficients of .391 and .309 respectively at significant level of 0.05.

Table 4.8: Spearman correlation between physics teachers' TK, TPK, TCK, PK, PCK, CK and TPCK from the learners' responses on the LCTTPCKQ Questionnaire

Variables	Learners Reported TK	Learners Reported TPK	Learners Reported TCK	Learners Reported PK	Learners Reported PCK	Learners Reported CK
Learners' Reported TPCK	.406**	.589**	.391*	.309*	.443**	.730**

*. Correlation is significant at the 0.05 level (2-tailed).

**. Correlation is significant at the 0.01 level (2-tailed).

In the figure 6, the six TPCK constructs on the left are linked with the TPCK on the right with dotted lines just as in figure 5. The correlation coefficients are then written on the lines.

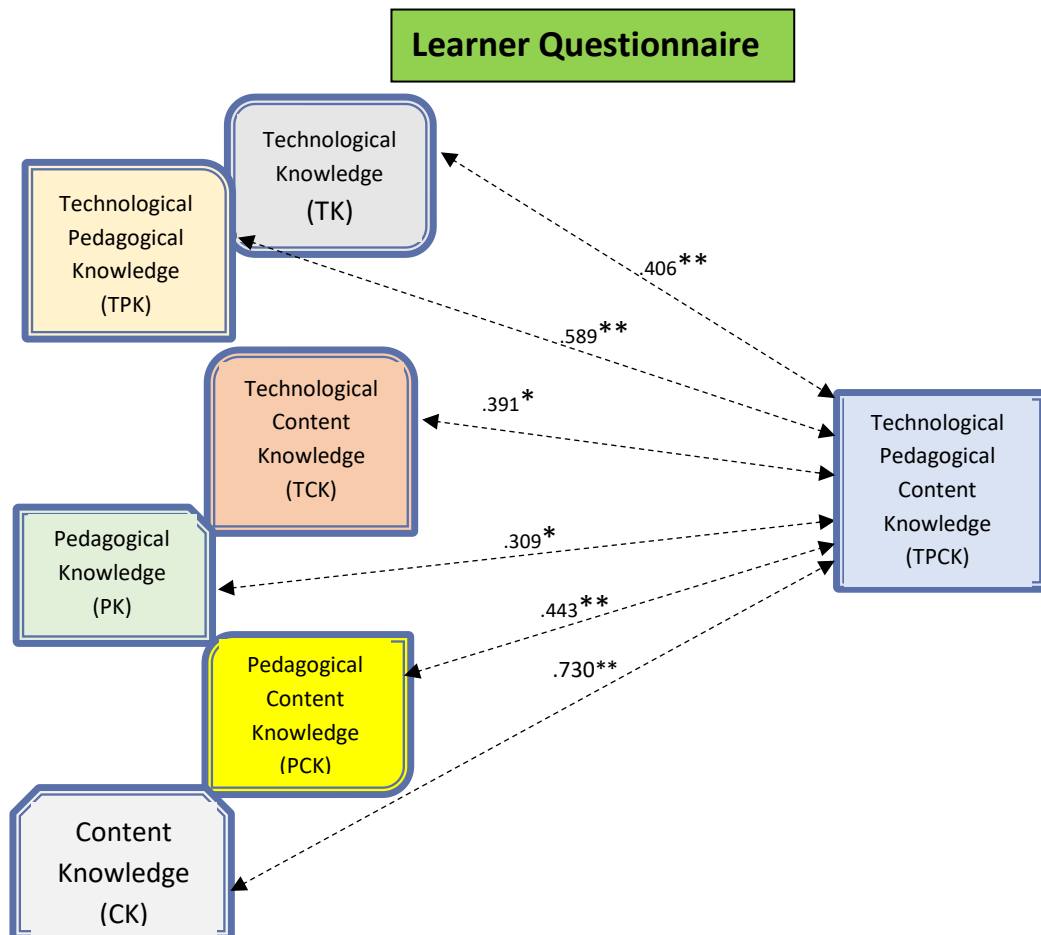

Figure 6: The correlation between the learners' responses on the Learners' LCTTPCKQ on the six TPCK constructs and the TPCK of their teachers.

4.2.3 t-Test

Figure 7 provides a clear diagrammatical view of the t-Test analysis. To compare the responses of the teachers on the PTTPCCKQ to their learners' responses on the LCTTPCKQ, t-test analytic tool using SPSS was employed under the following sub- sections and represented in figure 7. In the figure, the means from the t-Tests are written next to the constructs for both questionnaires. This was to determine if there are any corroborations between the learners' responses on the LCTTPCKQ and their teachers' responses on the PTTPCCKQ of the constructs of the Technological and Pedagogical Content Knowledge (TPCK). The learners' responses on the LCTTPCKQ were first tallied for all the 42 schools and the mode responses per question were taken as the learners' responses. The 17 questions were then categorised into the constructs of the TPCK and coded in SPSS as TK3, TK4, CK1, CK2, PK1, PK2, PK3, PK4, PK5, PK7, PCK, TCK, TPK1, TPK2, TPK6, TPK9, and TPCK. Averages of the constructs with two or more questions (TK, CK, PK, and TPK) were calculated for both the teacher and the learner questionnaires. This reduced the 17 questions to 7 (see section 4.2.3.8).

As mentioned in section 3.3.3.3, the LCTTPCKQ consists of six-point Likert Scale questions similar to that of the PTTPCCKQ and it was used to help elicit learners' confirmation or rejection of their teachers' response on the PTTPCCKQ. A few items deemed inappropriate for learners to respond to were removed to enable learners to respond to it. In summary, the LCPTTPCKQ has 17 items instead of the 27 for their teachers. The instrument is attached in Appendix 2. The t-Test was therefore performed on the 17 similar questions (which were further reduced to 7) of the LCPTTPCKQ and the PTTPCCKQ as shown in table 4.16.

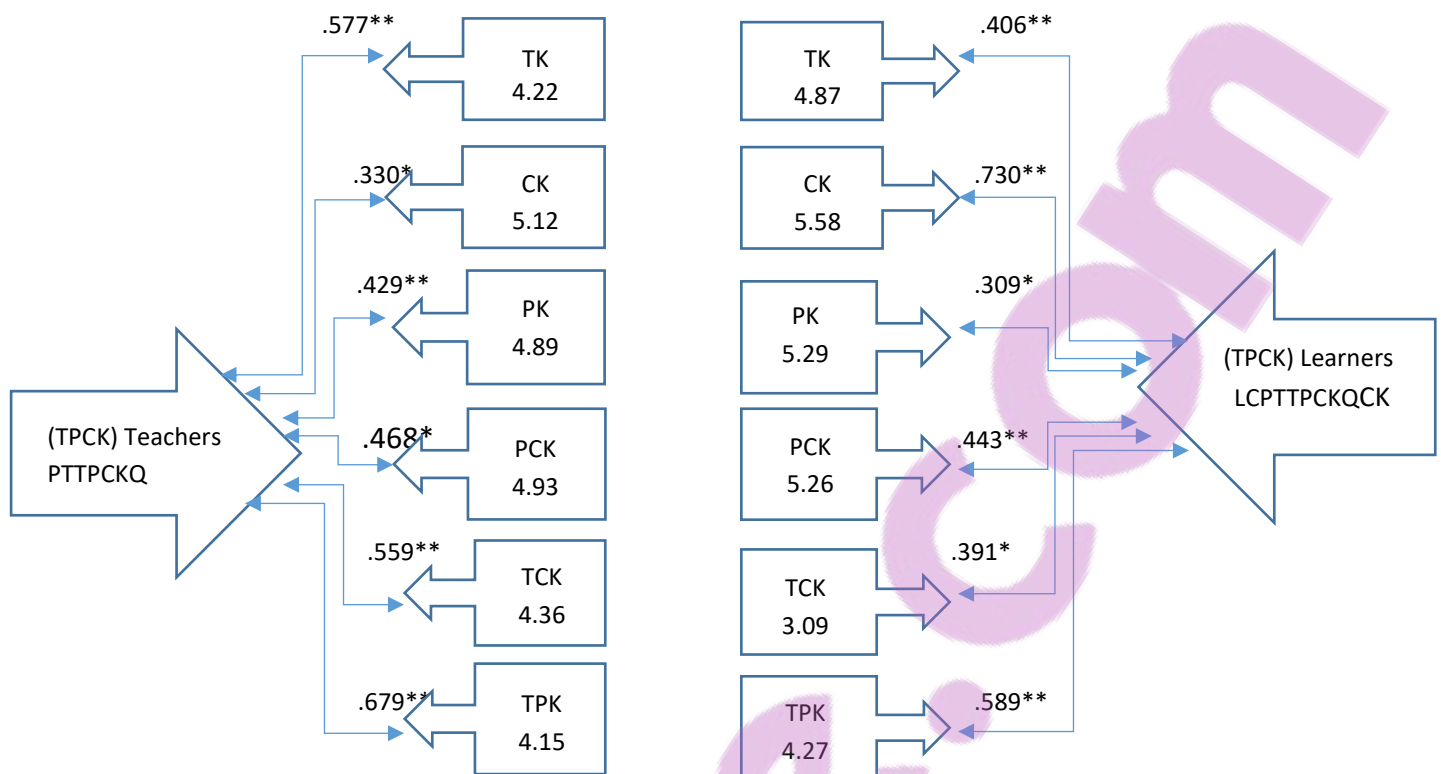

Figure 7: Comparison of the teachers' responses on the PTTTPCKQ and the learners' responses on the LCPTTPCKQ of the constructs of the TPCK framework showing the correlations and the t-Test means between the TPCK with its constructs.

4.2.3.1 t-Test comparison of the PTTTPCKQ responses and the LCPTTPCKQ responses on TK

The Likert Scale questionnaire used in this study uses the following scale: strongly disagree = 1, disagree = 2, slightly disagree = 3, slightly agree = 4, agree = 5, and strongly agree = 6. From table 4.9 (group statistics) the means of learners as well as that of their teacher are 4.8690 and 4.2262 respectively. Therefore, as the means of both learners and their teachers is greater than 4, it indicates that they corroborated each other on the constructs TK; they slightly agree to TK. The Independent Sample t-Test was used to compare the responses of the teachers and their learners to ascertain whether they differ significantly. Table 4.9 below shows the SPSS output of the independent samples t-Test on the TK of the PTTTPCKQ and LCPTTPCKQ questionnaires.

The results in table 4.9 (Independent Samples Test) shows that the significance value ($p < .05$) is less than .05 at 95% confidence interval ($\alpha = .05$) which means that the t-test (with 82 degrees of freedom) was statistically significant. This implies that the response of the learners on the LCPTTPCKQ ($M = 4.8690$, $s = 0.82683$) differed significantly from the response of the teachers on the PTPCKQ ($M = 4.2262$, $s = 1.14339$) on TK. The interpretation being that the difference is not due to chance.

Table 4.9: SPSS output of the independent samples t-Test of the PTPCKQ responses and the LCPTTPCKQ responses on TK

Group Statistics										
Respondent		N	Mean	Std. Deviation	Std. Error Mean					
TK for Both	Learners	42	4.8690	0.82683	0.12758					
	Teachers	42	4.2262	1.14339	0.17643					

Independent Samples Test										
		Equality of		t-test for Equality of Means						
		F	Sig.	t	df	Sig. (2-tailed)	Mean Difference	Std. Error Difference	Interval of the	
TK for Both	Equal variances assumed	7.222	0.009	2.953	82	0.004	0.64286	0.21773	0.20973	1.07598
	Equal variances not assumed			2.953	74.672	0.004	0.64286	0.21773	0.20909	1.07662

4.2.3.2 *t-Test comparison of the PTPCKQ responses and the LCPTTPCKQ responses on CK*

From table 4.10 below (group statistics) the means of the learners as well as their teachers' responses are 5.5833 and 5.1190 respectively for CK. The mean values of both learners and their teachers are greater than 5. It indicates that they corroborated each other on the constructs CK. On CK ($p < .05$) at 95% confidence interval ($\alpha = .05$) meaning that the t-test (with 82 degrees of freedom) in the (Independent Samples Test) table was statistically significant. This implies that the responses of the learners on the LCPTTPCKQ ($M = 5.5833$, s

= 0.48030) differed significantly from the response of the teachers on the PTTPCCKQ (M = 5.1190, s = 0.46606). The interpretation being that the difference is not due to chance.

Table 4.10: Table 4.10: SPSS output of the independent samples t-Test of the PTTPCCKQ responses and the LCPTTPCKQ responses on CK

Group Statistics					
Respondent		N	Mean	Std. Deviation	Std. Error Mean
CK for Both	Learners	42	5.5833	0.48030	0.07411
	Teachers	42	5.1190	0.46604	0.07191

Independent Samples Test										
		Equality of		t-test for Equality of Means						
		F	Sig.	t	df	Sig. (2-tailed)	Mean Difference	Std. Error Difference	Interval of the	
CK for Both	Equal variances assumed	2.028	0.158	4.496	82	0.000	0.46429	0.10327	0.25886	0.66971
	Equal variances not assumed			4.496	81.926	0.000	0.46429	0.10327	0.25885	0.66972

4.2.3.3 *t-Test comparison of the PTTPCCKQ responses and the LCPTTPCKQ responses on PK*

From table 4.11 below (group statistics) the results are as follows: on PK the means of the responses are 5.2937 and 4.8929 respectively. The mean values of both learners and their teachers are greater than 4. It indicates that they corroborated each other on the constructs PK.

On PK ($p < .05$) at 95% confidence interval ($\alpha = .05$) meaning that the t-test (with 82 degrees of freedom) in the (Independent Samples Test) table was statistically significant. This implies that the responses of the learners on the LCPTTPCKQ (M = 5.2937, s = 0.49906) differed significantly from the response of the teachers on the PTTPCCKQ (M = 4.8929, s = 0.75153).

The interpretation being that the difference is not due to chance.

Table 4.11: Table 4.11: SPSS output of the independent samples t-Test of the PTPCKQ responses and the LCPTTPCKQ responses on PK

Group Statistics					
Respondent		N	Mean	Std. Deviation	Std. Error Mean
PK for Both	Learners	42	5.2937	0.49906	0.07701
	Teachers	42	4.8929	0.75153	0.11596

Independent Samples Test										
		Equality of		t-test for Equality of Means						
		F	Sig.	t	df	Sig. (2-tailed)	Mean Difference	Std. Error Difference	Interval of the	
PK for Both	Equal variances assumed	3.939	0.051	2.879	82	0.005	0.40079	0.13920	0.12387	0.67771
	Equal variances not assumed			2.879	71.273	0.005	0.40079	0.13920	0.12325	0.67834

4.2.3.4 *t-Test comparison of the PTPCKQ responses and the LCPTTPCKQ responses on PCK*

Learners and their teachers corroborated each other on the PCK, LCPTTPCKQ (M = 5.2619) and PTPCKQ (M = 4.9286) as indicated in table 4.12 (Group Statistics) below. These mean values represent agreement as discussed under section 4.2.3.1. From the Independent Samples Test table below, it shows that ($p < .05$) at 95% confidence interval ($\alpha = .05$) meaning that the *t*-test (with 82 degrees of freedom) was statistically significant. This implies that the response of the learners on the LCPTTPCKQ differed statistically significantly from the response of the teachers on the PTPCKQ and these differences are not due to chance.

Table 4.12: SPSS output of the independent samples t-Test of the PTTPCCKQ responses and the LCPTTPCKQ responses on PCK

Group Statistics										
Respondent		N	Mean	Std. Deviation	Std. Error Mean					
PCK for Both	Learners	42	5.2619	0.73450	0.11334					
	Teachers	42	4.9286	0.71202	0.10987					

Independent Samples Test										
		Equality of		t-test for Equality of Means						
		F	Sig.	t	df	Sig. (2-tailed)	Mean Difference	Std. Error Difference	Interval of the	
									Lower	Upper
PCK for Both	Equal variances assumed	0.114	0.737	2.112	82	0.038	0.33333	0.15785	0.01933	0.64734
	Equal variances not assumed			2.112	81.921	0.038	0.33333	0.15785	0.01932	0.64735

3.2.3.5 *t-Test comparison of the PTTPCCKQ responses and the LCPTTPCKQ responses on TCK*

Under this section learners and their teachers did not corroborate each other on the TCK, LCPTTPCKQ (M = 3.0952) and PTTPCCKQ (M = 4.3571) as indicated in table 4.13 (Group Statistics) below. The learners’ mean value of 3.0952 indicates that they slightly disagree but their teachers slightly agree with the question on the TCK with a mean value of 4.3571. Then from the Independent Samples Test table, the significance value is less than .05 ($p < .05$) at 95% confidence interval ($\alpha = .05$) meaning that the t-test (with 82 degrees of freedom) was statistically significant. This implies that the mean value responses of the learners on the LCPTTPCKQ differed statistically significantly from the mean response of their teachers on the PTTPCCKQ and this difference is not due to chance.

Table 4.13: SPSS output of the independent samples t-Test of the PTTPCCKQ responses and the LCPTTPCKQ responses on TCK

Group Statistics					
Respondent		N	Mean	Std. Deviation	Std. Error Mean
TCK for Both	Learners	42	3.0952	1.97311	0.30446
	Teachers	42	4.3571	1.05510	0.16281

Independent Samples Test										
		Equality of		t-test for Equality of Means						
		F	Sig.	t	df	Sig. (2-tailed)	Mean Difference	Std. Error Difference	Interval of the	
									Lower	Upper
TCK for Both	Equal variances assumed	44.949	0.000	-3.655	82	0.000	-1.26190	0.34525	-1.94872	-0.57509
	Equal variances not assumed			-3.655	62.675	0.001	-1.26190	0.34525	-1.95191	-0.57190

4.2.3.6 *t-Test comparison of the PTTPCCKQ responses and the LCPTTPCKQ responses on TPK*

The learners and their teachers corroborated each other on TPK with the following mean values, LCPTTPCKQ (M = 4.2857) and PTTPCCKQ (M = 4.1508) as shown in table 4.14 (Group Statistics) below. From the Independent Samples Test table, the significance value is greater than .05, On TPK (p = .611), at 95% confidence interval ($\alpha = .05$), which indicates that their t-tests 82 degrees of freedom was not statistically significant. This implies that the mean value of the response of the learners on the LCPTTPCKQ does not differ statistically significantly from that of their teachers on the PTTPCCKQ as shown in table 4.14 (group statistics) below. The interpretation being the difference is due to chance.

Table 4.14: SPSS output of the independent samples t-Test of the PTTCKQ responses and the LCPTTPCKQ responses on TPK

Group Statistics					
Respondent		N	Mean	Std. Deviation	Std. Error Mean
TPK for Both	Leaners	42	4.2857	1.26222	0.19477
	Teachers	42	4.1508	1.15854	0.17877

Independent Samples Test										
		Equality of		t-test for Equality of Means						
		F	Sig.	t	df	Sig. (2-tailed)	Mean Difference	Std. Error Difference	Interval of the	
TPK for Both	Equal variances assumed	3.074	0.083	0.510	82	0.611	0.13492	0.26437	-0.39099	0.66084
	Equal variances not assumed			0.510	81.405	0.611	0.13492	0.26437	-0.39105	0.66089

4.2.3.7 *t-Test comparison of the PTTCKQ responses and the LCPTTPCKQ responses on TPK.*

The last question that appeared on both the teachers’ and learners’ questionnaire elicits TPK. It means that if the response to the last question (question 27 for teachers and question 17 for learners) is four (4), five (5) or six (6), then the teacher is reported to have TPK. The learners and their teachers corroborated each other on this as well; LCPTTPCKQ (M = 5.3333) and PTTCKQ (M = 4.1667) as indicated in table 4.15 (Group Statistics) below. These mean values represent agreement as discussed earlier. From the Independent Samples Test table below, it shows that ($p < .05$) at 95% confidence interval ($\alpha = .05$) meaning that the t-test (with 82 degrees of freedom) was statistically significant. This implies that the mean response of the learners on the LCPTTPCKQ differed statistically significantly from that of their teacher on the PTTCKQ as indicated in table 4.15 below and this difference is not due to chance.

Table 4.15: SPSS output of the independent samples t-Test of the PTTPCCKQ responses and the LCPTTPCKQ responses on TPCK

Group Statistics					
Respondent		N	Mean	Std. Deviation	Std. Error Mean
TPCK for Both	Leaners	42	5.3333	0.65020	0.10033
	Teachers	42	4.1667	1.22806	0.18949

Independent Samples Test										
		Equality of		t-test for Equality of Means						
		F	Sig.	t	df	Sig. (2-tailed)	Mean Difference	Std. Error Difference	Interval of the	
TPCK for Both	Equal variances assumed	10.170	0.002	5.441	82	0.000	1.16667	0.21441	0.74013	1.59321
	Equal variances not assumed			5.441	62.312	0.000	1.16667	0.21441	0.73810	1.59523

4.2.3.8 Summary of results of the t-Test comparison of the PTTPCCKQ responses and the LCPTTPCKQ responses of the 17 common questions

Table 4.16 below shows the summary results of the t-tests for each of the 17 common questions (which are now reduced to 7 due to the calculation of averages) on the PTTPCCKQ and LCPTTPCKQ at 95% confidence interval ($\alpha = .05$). In table 4.16 below are the question numbers, their codes, the mean values and the two-tailed significance (p) values as they appear in SPSS outputs from table 4.9 to 4.15 above to summarise all the SPSS outputs.

Table 4.16: Summary of results of the t-Test comparison of the PTTPCCKQ responses and the LCPTTPCKQ responses of the common questions

Questions	Codes	Means		Significance (p) value (2-tail)
		Learners	Teachers	
1	TK	4.8690	4.2262	.004*
2	CK	5.5833	5.1190	.000*
3	PK	5.2931	4.8929	.005*
4	PCK	5.2619	4.9286	.038*
5	TCK	3.0952	4.3571	.000*
6	TPK	4.2667	4.1508	.611
7	TCPK	5.3333	4.1667	.000*

* Statistically significant difference

The summary in table 4.16 above therefore shows that all the mean values are greater than 4 for both learners and teachers, except in TCK where it is below 4 for the learners. The Likert Scale questionnaire used in this study made use of the scale of 1 to 6 as Strongly Disagree = 1, Disagree = 2, Slightly Disagree = 3, Slightly Agree = 4, Agree = 5, and Strongly Agree = 6. Therefore, as the mean values of both learners and their teachers were above 4, it indicated that they corroborated each other on the constructs of all TPCK except TCK. But as the Significance p values of questions on all the TPCK constructs were less than (.05) except TPK, it implied that the mean values of the learners on the LCPTTPCKQ differed statistically significantly from those of their teachers on the PTPCKQ. This is interpreted, as the difference in the mean values is not due to chance. However, the Significance p values of questions on TPK was .611 and therefore greater than (.05), implying that the TPK responses of the learners on the LCPTTPCKQ did not differ significantly from the TPK responses of the teachers on the PTPCKQ.

4.2.4 Qualitative data analysis

4.2.4.1 Analysis of the Teacher Electricity Teaching Lesson Plans

There were 42 teacher participants in this study, of which 31 indicated in their responses on the PTPCKQ question 27 (Q27) that they have TPCK. This constituted 74% of the teachers with TPCK and the rest 11 (26%) of them reported no TPCK. The pie chart in figure 8 below represents this information more pictorially.

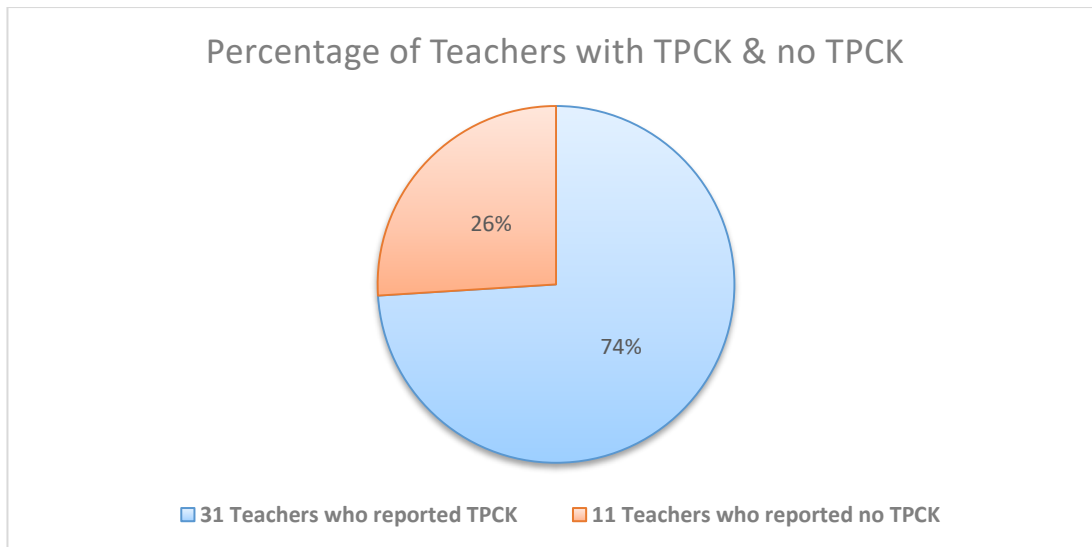

Figure 8: Percentage of teachers with TPCK and no TPCK.

After reviewing the PTTCKQ it become evident that many of the teachers did not provide qualitative data that is requested on the questionnaire for which spaces were provided. However, the majority of them merely indicated the scales of 1 to 6 in the appropriate boxes provided to indicate whether they agree or disagree with the 27 statements. Three examples of such responses from three different teachers for question 27(Q27) are shown in vignette 1, 2 and 3. These vignettes show that the teachers responded by writing 5, 6 and 5 in the appropriate boxes but did not elaborate to provide qualitative data.

Vignette 1

27 I can teach physics lessons that appropriately combine technologies and teaching approaches. 5

Vignette 2

27 I can teach physics lessons that appropriately combine technologies and teaching approaches.

Vignette 3

27 I can teach physics lessons that appropriately combine technologies and teaching approaches.

The teachers' electricity teaching lesson plans were also analysed as one of the research instruments (section 3.3.3 and 3.3.3.2). This was done to provide likely information on the types of technologies the teachers use in their classroom. Fourteen (14) teachers constituting 33% of the participants did not provide any lesson plans. Seven (7) teachers (17%) provided lesson plans with no indication of any technology usage in the lesson. Teachers are expected to have lesson plans written before going to teach the lessons. However, this not what is happening in the schools as I visited the schools to collect data. Teachers now rely on prepared lesson plans by textbook writers and lesson plans from other sources. An example of these lesson plans can be found in Appendix 15. Two of the teachers provided a lesson plan they received from another province (via The Gauteng Department of Education) which also did not indicate any technology usage in the lessons (see Appendix 16). However, eight (8) teachers (19%) provided a lesson plan from Doc Scientia, a company that compiles educational materials for schools, learners and educators in Physical Sciences, Technical Sciences and the Natural Sciences (see appendix 17). The pie chart in figure 9 below represents this information pictorially:

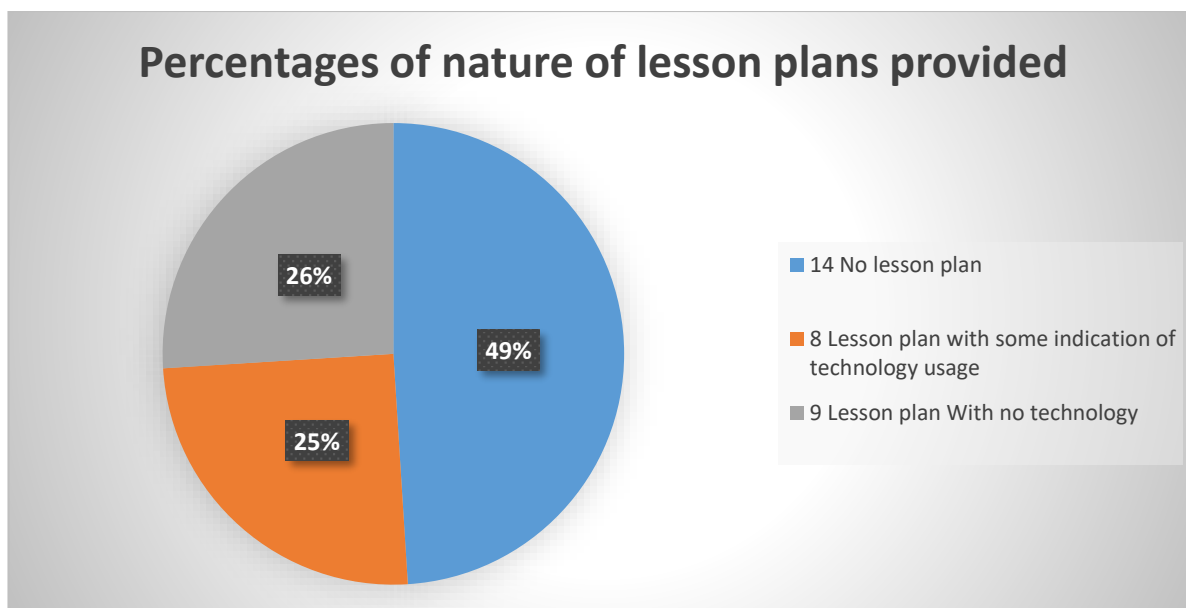



Figure 9: Percentage of nature of lesson plans provided by the teachers

In the Doc Scientia lesson plan, under the heading ‘resources’, Doc Scientia Physical Sciences Textbook 1 Grade 11, Page 256 – 304 was the resource indicated to be used for the delivery of the lessons (Bernardo, du Plessis, du Plessis, Fanoy, Jones, Lees – Rolfe, Reynecke, Schmidt, Smith, 2015). In the textbook, page 267 has 2 Quick Response (QR) codes which learners and teachers can scan using their smart phones and tablets with the QR code scanner application installed. A YouTube weblink then appears, which takes them straight to videos and simulations relating to the topic. Page 269 also had 3 of these QR codes as well. This presents 5 different weblinks for electric circuits alone. Below is vignette 4 and vignette 5 showing pages 267 and 269 of the Doc Scientia textbooks which displays the QR codes mentioned:

Vignette 4

electricity and magnetism

Examples

- An electric current flows through an ohmic resistor. When a current of 0,2 A flows through the resistor, the voltmeter connected across it reads 5 V. Calculate a) the resistance of the resistor and b) the current flowing through the resistor when the voltmeter reads 7,2 V.

a) $R = \frac{V}{I}$
 $= \frac{5}{0,2}$
 $= 25 \Omega$

b) $I = \frac{V}{R}$
 $= \frac{7,2}{25}$
 $= 0,288 \text{ A}$

- The current flowing through an ohmic resistor is I when the potential difference across the resistor is V. The temperature of the resistor remains constant. What current flows through the resistor when the potential difference across it is halved? Motivate your answer.

From Ohm's law $V \propto I$ for an ohmic resistor at a constant temperature. If V is halved then I will also be halved. The current is therefore $\frac{1}{2}I$.

Interesting facts

Did you know that your skin is a resistor?
 What current flows through a person who touches a 240 V power point?
 Wet skin $\pm 1\,000 \Omega$ $I = \frac{V}{R} = \frac{240}{1\,000} = 240 \text{ mA}$ (= fatal)
 Dry skin (young) $\pm 10\,000 \Omega$ $I = \frac{V}{R} = \frac{240}{10\,000} = 24 \text{ mA}$ (= serious shock)
 Dry skin (old) $\pm 100\,000 \Omega$ $I = \frac{V}{R} = \frac{240}{100\,000} = 2,4 \text{ mA}$ (= light shock)

Quick facts

The hotter the conductor, the higher the resistance

Do you still remember?

Resistors in series

The same current flows through each of the resistors in series in a circuit.

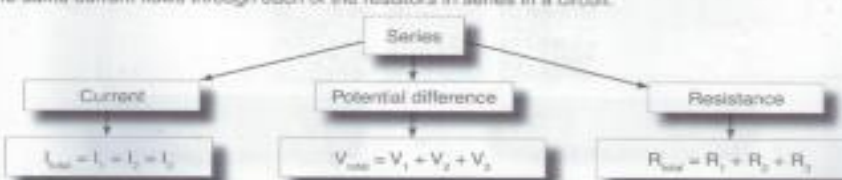

```

graph TD
    Series[Series] --> Current[Current]
    Series --> PD[Potential difference]
    Series --> Resistance[Resistance]
    Current --> I_tot["I_tot = I_1 = I_2 = I_3"]
    PD --> V_tot["V_tot = V_1 + V_2 + V_3"]
    Resistance --> R_tot["R_tot = R_1 + R_2 + R_3"]
    
```

Doc Scientia PHYSICS textbook and workbook - Grade 11 267

Vignette 5

electricity and magnetism

Examples

Consider the following section of a circuit. The voltmeters have very large resistance. Calculate the values of the readings on V_1 and V_2 respectively.

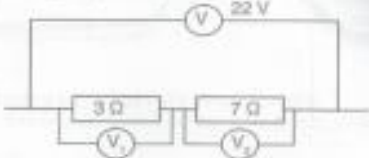

Solution:
Potential difference divides in ratio 3:7

$$V_1 = \left(\frac{3}{10}\right)22$$

$$V_1 = 6,6 \text{ V}$$

$$V_2 = \left(\frac{7}{10}\right)22$$

$$V_2 = 15,4 \text{ V of } 22 - 6,6 = 15,4 \text{ V}$$

Examples

Consider the following section of a circuit. The ammeters do not have any resistance. Calculate the values of the readings on ammeters A_1 and A_2 respectively if the reading on ammeter A = 1,5 A.

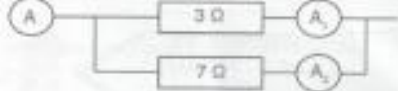

Solution:
Current divides in ratio 7:3

$$\therefore I_1 = \frac{7}{10} \times 1,5$$

$$= 1,05 \text{ A}$$

$$\therefore I_2 = \frac{3}{10} \times 1,5$$

$$= 0,45 \text{ A}$$

Note
The smaller resistor allows the larger current through.



Doc Scientific PHYSICS textbook and workbook - Grade 11 269

To ascertain which technologies the 31 teachers who reported having TPCK are using in their classroom, I phoned them as a follow up to request that they elaborate on their responses to question 27 (Q27) as the majority of them did not complete the questionnaire fully. Table 4.17 below represents the 31 teachers' codes, their responses to Q27 on the Likert Scale, their telephonic responses on the type of technologies they use in their classrooms, and information on their lesson plans.

Table 4.17: Physics teachers with TPCK and the technologies they use in their classrooms (N=31)

Teacher Code	Q27	Telephonic Responses from Teachers	Lesson Plan Provision
1	5	Did not answer the phone	Doc Scientia lesson plan
2	5	Did not answer the phone	No lesson plan presented
4	6	PhET Simulations, YouTube Videos and Power Point Presentations	No lesson plan presented
5	4	Did not answer the phone	No Technology indicated in lesson plan
6	4	Did not answer the phone	No Technology indicated in lesson plan
8	5	Did not answer the phone	No lesson plan presented
9	6	Mindset Videos, YouTube Videos and Power Point Presentations	No lesson plan presented
11	6	Did not answer the phone	No lesson plan presented
12	4	Did not answer the phone	No Technology indicated in lesson plan
13	6	Interactive White Board, Mindset Videos, PhET Simulations, YouTube Videos and Power Point Presentations	Doc Scientia lesson plan
15	5	Smart Board, Mindset Videos, YouTube Videos and Power Point Presentations	Doc Scientia lesson plan
16	5	Interactive White Board, Mindset Videos, YouTube Videos and Power Point Presentations	Doc Scientia lesson plan
17	5	Did not answer the phone	Doc Scientia lesson plan
18	4	Did not answer the phone	No Technology indicated in lesson plan
19	4	Did not answer the phone	No Technology indicated in lesson plan
20	5	Simulations, Mindset Videos, YouTube Videos and Power Point Presentations	Departmental lesson plan with no technology indicated.
21	4	Did not answer the phone	No Technology indicated in lesson plan
22	5	Did not answer the phone	No lesson plan presented
23	4	Did not answer the phone	Doc Scientia lesson plan
26	5	Did not answer the phone	No lesson plan presented
29	4	Did not answer the phone	No Technology indicated in lesson plan
30	5	Did not answer the phone	No lesson plan presented
31	4	Mindset Videos, YouTube Videos and Power Point Presentations	Departmental lesson plan with no technology indicated.
34	4	Interactive White Board, YouTube Videos and Power Point Presentations	No lesson plan presented
36	4	Did not answer the phone	No lesson plan presented
37	5	Interactive White Board, YouTube Videos, Power Point Presentations and Simulations	No lesson plan presented
38	4	Did not answer the phone	No lesson plan presented
39	5	Did not answer the phone	No lesson plan presented
40	6	Interactive White Board, Simulations, YouTube Videos and Power Point Presentations	Doc Scientia lesson plan
41	4	Did not answer the phone	No lesson plan presented
42	5	PhET Simulations, YouTube Videos and Power Point Presentations	Doc Scientia lesson plan

With reference to table 4.17, it is clear that 20 out of the 31 teachers were evasive and did not answer the phone to respond to the telephonic questions. However, 3 of the 20 provided Doc Scientia lesson plans, and this presupposes that they or their learners may be using the weblinks (QR codes on vignette 4 and 5) indicated in the Doc Scientia textbook. The eleven (11) teachers who responded indicated that they use technology. The pie chart in Figure 10 below represents this information:

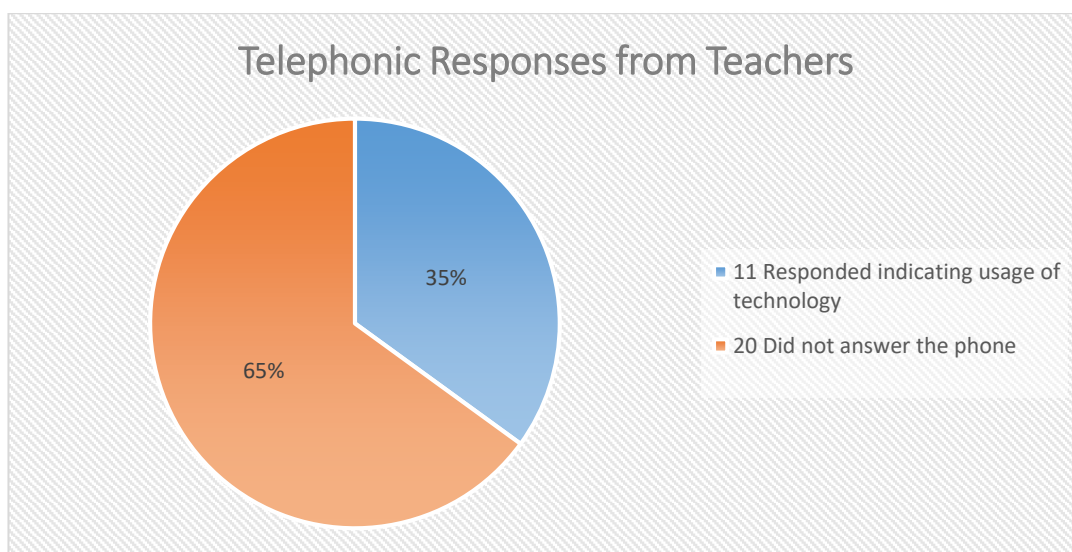

Figure 10: Percentage of telephonic Responses (follow up) from the teachers.

The 11 teachers who responded indicated that they used PhET Simulations, YouTube Videos, Power Point Presentations, Interactive White Boards, and Mindset Videos. Three examples of such responses (vignette 6 to 8) from three different teachers to question 27(Q27) are shown below. These vignettes were sample responses from the few teachers who answered the qualitative part of the PTPCKQ questionnaire. The samples of vignettes below also show responses to question 26(Q26) because they further strengthen the explanation in Q27. For instance, in vignette 6, the teacher's response on statement 26 indicated that the teacher

uses simulations when there is no apparatus for practical lessons. This response indicates that the teacher has TPCK and that is what statement 27 (Q27) was eliciting. In vignette 7 the teacher's response also mentioned the use of simulations to enhance lessons in statement 26.

Vignette 6

- 26 I can choose technologies that enhance the content for a lesson. 5
I normally use simulations to teach
my learners practical lessons where there are no apparatus
- 27 I can teach physics lessons that appropriately combine technologies and teaching approaches. 5
I use simulations to unearth that
enquiries love in learners using simulations

Vignette 7

- 26 I can choose technologies that enhance the content for a lesson. 5
Mindset donation helped me see good
simulations for lesson enhancement.
- 27 I can teach physics lessons that appropriately combine technologies and teaching approaches. 5
only ready made lesson from Mindset
helps me in this approach.

The third example (vignette 8) below displays other responses such as responses on statements 2, 3, 4, 5, 13, 21, 25, and 26 because in the statement in question 27 (Q27), the teacher responded "as mentioned above, I can integrate technology and teaching approaches." The responses in statements 2, 3, 4, 5, 13, 21, 25 and 26, mentioned simulations, smartboards and other relevant technologies among others, which is an indication of technology usage in the classroom by this teacher. A few of these schools are designated Science, Mathematics

and Technology (SMT) Schools, so they have some of these facilities supplied by the Mpumalanga Department of Education.

Vignette 8

- 2 I can learn technology easily. 5
I'm Computer Literate and Can use Simulations to teach my learners.
- 3 I frequently play around with the technology. 5
I like to browse the internet for info on educational esp. Science Content.
- 4 I know about a lot of different technologies. 5
I Know about Simulations, internet using a Computer and Smartboard.
- 5 I have the technical skills I need to use technology. 5
I Can operate a Computer with ease and use it or incorporate it in my lesson
- 13 I can use a wide range of teaching approaches in a classroom setting. 4
I use normal teaching methods, Smartboard, Simulations & group work.
- 21 I am thinking critically about how to use technology in my classroom. 6
Technology is now part of our lives, I always try to incorporate it in my lessons
- 25 I can provide leadership in helping others to coordinate the use of content, technologies and teaching approaches at my school. 6
As one of Computer literate educators in the school, I'm always available to help others.
- 26 I can choose technologies that enhance the content for a lesson. 6
I Can easily choose relevant technologies to enhance my lessons
- 27 I can teach physics lessons that appropriately combine technologies and teaching approaches. 5
Already mentioned above, I can intergrate technology and teaching approaches

4.2.4.2 *Sections of electricity in the CAPS physics syllabus which were reported by learners that their teachers were neglecting to teach*

Table 4.18 below shows the participating 42 schools with the number of their learners responding 'no' to various sections of the 21 sub-sections of the main topic electricity, according to the CAPS document on the Learner Electricity Learning Confirmatory Questionnaire (LELCQ). At the top of the table are the 21 sub sections and below it, the number of 'no' responses per section per school. Below all the 'no' responses for the 42 schools are the totals of the 'no' responses per section and then a calculation of their percentages. This is to help determine the sections of electricity that teachers were neglecting to teach according the learners.

The LELCQ instrument was discussed (see section 3.3.3.4 and Appendix 3). From table 4.18 below, it is clear that, sections 3, 12, 21, 4, 19, 20, 15 and 18 out of the 21 sections had percentages greater than five percent (5%) with section 3, having the highest percentage of 12.9%. Section 12 (9.3%), section 21 (8.1%), section 4 (8%), section 19 (5.8%), section 20 (5.8%), section 15 (5.5%), and section 18 is (5.2%). This information is also summarised in the bar chart in Figure 11 below.

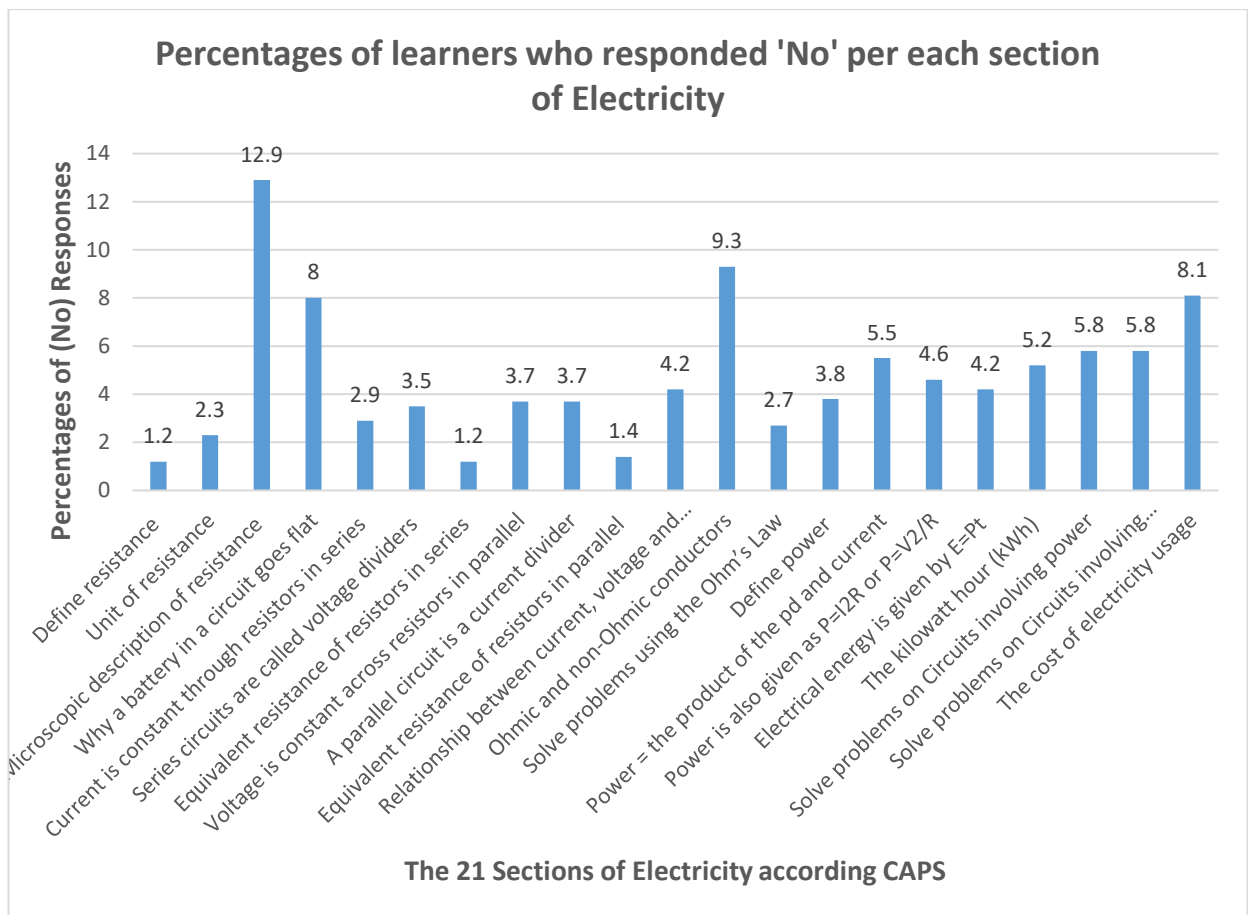

Figure 11: Percentages of learners who responded 'no' per each section of electricity

These sections are also on the instrument (see Appendix 3) as: define resistance; difference between Ohmic and non-Ohmic conductors; the cost of electricity usage; why a battery in a circuit goes flat. The others concerned solving problems, involving circuits, including the concept of power; including the concept of electrical energy; electrical power dissipated in a device is equal to the product of the potential difference across the device and current flowing through it i.e. $P=IV$ and then finally the kilowatt hour (kWh), which refers to the use of 1 kilowatt of electricity for 1 hour.

Table 4.18: Responses on the number of learners who responded 'no' per each section of electricity they were expected to be taught on LELCQ Questionnaire

	The 21 Sections of Electricity according to CAPS																				
	1	2	3	4	5	6	7	8	9	10	11	12	13	14	15	16	17	18	19	20	21
	Define resistance	Unit of resistance	Microscopic description of resistance	Why a battery in a circuit goes flat	Current is constant through resistors in series	Series circuits are called voltage dividers	Equivalent resistance of resistors in series	Voltage is constant across resistors in parallel	A parallel circuit is a current divider	Equivalent resistance of resistors in parallel	Relationship between current, voltage and resistance	Ohmic and non-Ohmic conductors	Solve problems using the Ohm's Law	Define power	Power = the product of the pd and current	Power is also given as $P=I^2R$ or $P=V^2/R$	Electrical energy is given by $E=Pt$	The kilowatt hour (kWh)	Solve problems on Circuits involving power	Solve problems on Circuits involving electrical energy	The cost of electricity usage
Schools	Number of learners who responded (No) per section																				
1	0	0	18	8	1	3	0	1	2	0	3	18	3	0	0	2	6	7	4	4	10
2	0	0	12	12	0	2	0	1	0	3	1	1	0	10	10	8	8	6	6	4	11
3	0	0	11	2	0	0	0	1	0	0	3	12	0	0	0	0	0	0	1	1	0
4	0	0	3	3	6	1	0	5	7	0	2	2	1	1	2	0	0	1	4	0	1
5	2	1	25	14	8	8	4	7	4	3	7	6	5	3	6	5	3	4	6	2	2
6	5	0	22	13	0	5	0	1	2	2	3	0	1	1	2	1	0	0	1	2	2
7	0	2	9	6	1	6	0	1	1	1	1	1	2	0	3	0	0	0	2	5	3
8	6	13	7	13	8	10	3	13	2	4	3	7	5	7	7	7	9	6	12	10	15
9	1	1	5	8	1	1	1	0	1	0	0	3	0	0	2	0	1	1	0	1	0
10	0	14	5	9	6	8	0	12	3	0	5	15	0	3	3	1	5	6	7	6	11
11	0	0	0	0	0	0	0	0	0	0	0	0	0	0	0	0	0	0	0	0	0
12	0	3	23	13	4	1	0	4	2	0	7	12	3	2	3	1	3	1	5	9	0
13	1	6	12	7	10	8	4	4	14	1	10	13	6	5	11	9	7	5	6	3	6
14	2	3	28	19	7	7	0	6	10	0	3	22	2	0	3	0	0	2	2	8	2
15	0	1	6	2	0	1	0	1	1	0	3	1	0	0	0	0	0	1	1	1	1
16	0	1	8	4	0	0	0	0	0	0	3	1	0	0	0	0	0	1	1	0	0
17	7	3	40	23	3	17	5	14	20	2	15	19	7	6	16	8	11	21	16	10	34
18	9	2	9	8	6	13	5	9	10	6	9	20	8	10	15	16	9	13	19	15	15
19	0	0	10	2	1	0	0	1	0	0	3	13	0	0	0	0	0	0	1	1	0
20	4	6	34	19	17	6	2	4	6	3	26	24	6	9	10	8	5	13	21	21	41

Table 4.18: continued

	The 21 Sections of Electricity according to CAPS																				
	1	2	3	4	5	6	7	8	9	10	11	12	13	14	15	16	17	18	19	20	21
	Define resistance	Unit of resistance	Microscopic description of resistance	Why a battery in a circuit goes flat	Current is constant through resistors in series	Series circuits are called voltage dividers	Equivalent resistance of resistors in series	Voltage is constant across resistors in parallel	A parallel circuit is a current divider	Equivalent resistance of resistors in parallel	Relationship between current, voltage and resistance	Ohmic and non-Ohmic conductors	Solve problems using the Ohm's Law	Define power	Power = the product of the pd and current	Power is also given as $P=I^2R$ or $P=V^2/R$	Electrical energy is given by $E=Pt$	The kilowatt hour (kWh)	Solve problems on Circuits involving power	Solve problems on Circuits involving electrical energy	The cost of electricity usage
Schools	Number of learners who responded (No) per section																				
21	1	0	5	1	2	0	0	2	0	0	1	0	0	0	2	1	0	1	0	1	3
22	0	1	9	7	1	6	0	1	1	2	2	2	0	3	0	0	0	2	4	3	
23	0	2	3	1	1	2	1	6	7	0	1	10	3	2	4	3	3	12	7	7	16
24	1	2	5	0	3	2	1	5	3	0	0	2	3	1	4	1	2	1	2	2	1
25	0	0	12	12	0	2	0	1	0	3	1	1	0	13	13	12	12	10	10	8	11
26	0	0	24	15	4	2	1	3	4	1	2	23	1	1	6	11	6	7	13	12	9
27	1	1	9	13	0	1	3	1	3	0	6	11	5	18	18	12	11	13	10	12	21
28	1	1	12	8	0	0	2	1	2	0	9	9	5	14	10	10	8	6	6	10	18
29	2	2	14	7	4	2	3	3	3	3	3	7	3	1	4	3	4	0	5	5	3
30	0	3	6	7	6	5	5	8	2	6	5	4	7	5	9	7	3	3	5	4	2
31	0	1	29	29	2	0	0	3	1	0	0	28	1	0	5	1	6	14	2	3	26
32	1	7	41	11	7	12	5	14	11	9	22	45	19	11	16	19	7	12	11	17	16
33	0	0	4	0	1	1	1	0	0	1	0	2	1	17	19	22	22	22	21	19	15
34	0	5	2	1	1	0	1	0	0	1	1	1	0	1	0	0	0	0	1	1	
35	2	6	22	7	0	3	0	5	3	1	8	20	3	1	6	7	9	2	4	4	2
36	1	1	8	3	0	0	0	0	2	1	0	4	0	0	0	0	0	0	1	1	0
37	1	1	7	7	2	2	1	5	6	1	2	8	4	9	9	9	8	11	10	10	12
38	0	1	5	1	1	2	1	4	7	0	1	8	3	2	4	3	3	10	6	7	15
39	0	0	0	1	0	0	0	0	0	0	0	0	0	0	0	0	1	0	1	0	0
40	2	2	5	3	0	0	0	0	2	1	0	4	0	0	0	0	0	0	2	2	0
41	0	2	15	7	2	5	0	2	6	0	0	0	2	1	1	0	1	1	4	3	0
42	0	0	1	0	1	0	0	0	1	2	0	0	0	0	0	0	0	0	0	0	0
TOTALS	51	96	528	330	122	150	56	157	158	67	182	391	124	168	241	203	190	231	256	255	349
Percentages	1.2	2.3	12.9	8	2.9	3.5	1.2	3.7	3.7	1.4	4.2	9.3	2.7	3.8	5.5	4.6	4.2	5.2	5.8	5.8	8.1

Table 4.19 below shows the participating 42 schools with the numbers and percentages of their learners who passed the various items on the LEAT test. At the top of the table are the questions divided into five items as questions 1, 2, 3.1, 3.2, 4.1 and 4.2. The number of learners who passed these items per school are represented and their percentages calculated using Microsoft Excel.

Below all the number of learners who passed these items for the 42 schools are the totals and then a calculation of the total percentages. This is to help determine the items on the test that learners perform less. These items with fewer performances will then be compared with sections of electricity that teachers were neglecting to teach to enable the researcher to determine if there are any correlations.

On the LEAT test, question 1 is on one-word type items, question 2 is on multiple choice, question 3.1 is on calculation of cost of electric energy using electric power and question 3.2 is on ways to save electricity cost at home. Question 4.1 is on circuits and how to investigate the relationship between the current passing through and the potential difference across resistor in terms of dependent and independent variables. In addition they had to indicate how to use these variables from a graph to calculate the gradient of the graph and hence calculate the resistance of the resistor as captured in sub questions of 4.1. Question 4.2 is on how to calculate the effective resistance of the circuit, how to calculate voltage, and how to calculate the resistance of a resistor in the given electric circuit as in the sub questions of question 4.2.

From table 4.19, the percentage of learners who passed the different items on the test can be seen from the bottom part of the table as question 1 is 73%, question 2 is 69%, question 3.1 is 53%, question 3.2 is 86%, question 4.1 is 62% and question 4.2 is 30%.

This analysis from table 4.19 show that 70% of the learners fail to answer question 4.2 correctly. The question (4.2), is on how to calculate the effective resistance of the circuit, how to calculate voltage, and how to calculate the resistance of a resistor in the given electric circuit. The analysis from table 4.19 is consistent with that in table 4.18 where 5.8% of the learners reported that teachers neglected to teach section 15 (electrical power dissipated in a device is equal to the product of the potential difference across the device and current flowing through it i.e. $P=IV$) and section 19 (how to solve/calculate problems involving: Circuits, including the concept of power) and these are the sections on which question 4.2 is based.

Question 3.1 also had 47% of the learners who fail to answer it correctly. The question (3.1), is on how to calculate the cost of electric energy using electric power. The analysis from table 4.19 is consistent with that in table 4.18 where 8.1% of the learners reported that teachers neglected to teach section 21 (the cost of electricity usage, given the power specifications of appliances used and the duration if the cost of 1 kWh is given). 38% of the learners failed to answer question 4.1 correctly. This is also consistent with that in table 4.18 where 4.2% of the learners reported that teachers neglected to teach section 11 (how to determine the relationship between current, voltage and resistance at constant temperature using a simple circuit)

Table 4.19: Number and percentage of learners who passed question items on the LEAT test

School Code	No. Wrote	Questions											
		Q1		Q2		Q3				Q4			
		No. Passed		No. Passed		No. Passed		No. Passed		No. Passed		No. Passed	
		Q1	%	Q2	%	Q3.1	%	Q3.2	%	Q4.1	%	Q4.2	%
1	33	33	100	24	73	33	100	33	100	25	76	4	12
2	21	17	81	10	48	4	19	15	71	10	48	4	19
3	16	10	63	10	63	8	50	15	94	9	56	1	6
4	11	11	100	4	36	3	27	10	91	9	82	5	45
5	59	34	58	39	66	40	68	50	85	42	71	9	15
6	46	20	43	26	57	27	59	30	65	17	37	0	0
7	17	8	47	8	47	7	41	15	88	10	59	3	18
8	17	10	59	10	59	6	35	14	82	13	76	0	0
9	12	11	92	12	100	11	92	9	75	8	67	8	67
10	29	28	97	22	76	13	45	24	83	21	72	2	7
11	13	8	62	10	77	8	62	13	100	7	54	8	62
12	48	44	92	44	92	47	98	41	85	35	73	47	98
13	71	24	34	40	56	33	46	66	93	26	37	9	13
14	51	41	80	31	61	34	67	47	92	42	82	40	78
15	30	17	57	20	67	16	53	27	90	15	50	5	17
16	29	16	55	22	76	15	52	23	79	14	48	7	24
17	51	43	84	30	59	25	49	48	94	43	84	1	2
18	43	17	40	19	44	8	19	40	93	11	26	2	5
19	16	16	100	11	69	9	56	14	88	16	100	3	19
20	79	70	89	62	78	15	19	73	92	52	66	45	57
21	15	11	73	10	67	1	7	12	80	13	87	0	0
22	19	18	95	16	84	3	16	14	74	16	84	2	11
23	44	28	64	32	73	41	93	34	77	39	89	4	9
24	9	2	22	4	44	9	100	8	89	3	33	0	0
25	20	20	100	9	45	7	35	16	80	15	75	0	0
26	47	35	74	35	74	28	60	45	96	40	85	38	81
27	39	38	97	26	67	0	0	31	79	39	100	24	62
28	20	10	50	10	50	16	80	10	50	9	45	2	10
29	22	13	59	11	50	21	95	17	77	8	36	4	18
30	37	30	81	23	62	4	11	36	97	7	19	0	0
31	37	27	73	22	59	12	32	33	89	23	62	4	11
32	91	82	90	69	76	44	48	77	85	48	53	28	31
33	31	29	94	26	84	0	0	28	90	27	87	5	16
34	32	13	41	22	69	9	28	20	63	7	22	4	13
35	61	52	85	42	69	48	79	56	92	26	43	14	23
36	29	10	34	20	69	8	28	20	69	14	48	3	10
37	20	20	100	20	100	20	100	20	100	20	100	16	80
38	29	21	72	20	69	2	7	21	72	20	69	6	21
39	18	15	83	14	78	18	100	17	94	5	28	3	17
40	31	19	61	30	97	31	100	31	100	28	90	24	77
41	47	36	77	28	60	44	94	43	91	17	36	19	40
42	33	32	97	33	100	30	91	32	97	30	91	28	85
TOTAL	1423	1039	73	976	69	758	53	1228	86	879	62	435	30

4.3 Answering the research questions.

The results of the data analyses presented from sections 4.2 above were used to answer the research questions that guided this study. These questions are addressed in the following sections.

4.3.1 Research question one

The first research question as stated under section 1.5 was: What is the relationship between physics teachers' technological and pedagogical content knowledge and (their) learners' achievement?

In order to answer this research question, there was the need to determine the possible relationship between the physics teachers' technological and pedagogical content knowledge (TPCK) and (their) learners' achievement. Teachers' TPCK was measured using the physics Teachers' Technological and Pedagogical Content Knowledge Questionnaire (PTTPCKQ) and their learners answered Learners' Confirmation of Physics Teachers' Technological and Pedagogical Content Knowledge Questionnaire (LCPTTPCKQ) to confirm or reject their teachers' reported TPCK (see section 3.3.2).

Learners also wrote the Learner Electricity Achievement Test (LEAT) as a measure of physics teachers' learners' achievement. In addition to the above-mentioned instruments, the lesson plans (Teachers Electricity Teaching Lesson Plans (TETLP)) used by the teachers to teach electricity was also collected and analysed as stated above.

To answer the question of whether there is any relationship between physics teachers' technological and pedagogical content knowledge and their learners' achievement, the data gathered was analysed quantitatively using inferential statistics. The data was analysed using correlation analysis while statistical inference was taken at 0.05 alpha level. There was a positive statistical relationship between physics teachers' TPCK and their learners' achievement, but this was not statistically significant. The result is displayed in Table 4.2 [Spearman's rho (42) = .28, p = .072].

4.3.2 Research question two

The second research question was: What is the relationship between physics teachers' technological and pedagogical content knowledge and their demographics, such as qualifications, teaching experience, age and gender? As shown in table 4.2, it was found that a positive, statistically significant relationship existed between physics teachers' experience and their learners' achievement [Spearman's rho (42) = .39, p = .011], as well as physics teachers' TPCK and their qualifications [Spearman's rho (42) = .33, p = .003].

A chi-square test was used to determine the relationship between physics teachers' TPCK, gender and their age (tables 4.3 & 4.4 and 4.5 & 4.6 respectively). This statistical test is used to compare observed data with the expected data. From table 4.4, the Pearson chi-square test of independence was performed to examine the relation between physics Teachers' Technological Pedagogical Content Knowledge (TPCK) and physics teachers' gender. The relationship between these variables was not statistically significant; $\chi^2(5, N = 42) = 2.879, p$

= .719. This implied that there was no relationship between physics teachers' gender and their TPCK. The chi-square test in table 4.6 was used to determine the association between physics teachers' TPCK and their age. As evident in table 4.6, the relation between these variables was not significant, $\chi^2(15, N = 42) = 16.613, p = .343$. This implied that there is no relationship between physics teachers' age and their TPCK.

In summary, a positive, statistically significant relationship existed between physics teachers' experience and their learners' achievement as well as physics teachers' TPCK and their qualifications. However, there was no statistically significant relationship between physics teachers' gender and their TPCK as well as their age and their TPCK.

4.3.3 Research question three

The third research question was: What is the relationship between the six TPCK constructs and the TPCK from teachers' perspective?

In order to answer this research question, the need was to determine the possible relationship between the physics Teachers' Technological Knowledge(TK), Content Knowledge(CK), Pedagogical Knowledge(PK), Technological Content Knowledge(TCK), Pedagogical Content Knowledge(PCK), and Technological Pedagogical Knowledge(TPK) against their Technological and Pedagogical Content Knowledge(TPCK). Physics teachers' TPCK was measured using the Technological and Pedagogical Content Knowledge Questionnaire (PTTPCKQ) as discussed under section 3.3.2.

The data was analysed quantitatively using inferential statistics also. The data was analysed using correlation analysis while statistical inference was taken at 0.05 and 0.01 alpha levels. There was a positive statistically significant relationship between physics teachers' TK and TPCK, CK and TPCK, PK and TPCK, TCK and TPCK, PCK and TPCK as well as TPK and TPCK. The result as displayed in Table 4.3 as well as Figure 4, shows that the TPCK constructs with the highest positive statistically significant correlations with the TPCK are TPK at .679 followed by TK at .577, TCK at .559, PCK at .468 and PK at .429; all at 0.01 significant level. The CK is also positive statistically significant with the TPCK but with the least correlation value of .330 at 0.05 significant level.

4.3.4 Research question four

The fourth research question was: What is the relationship between the six TPCK constructs and the TPCK from learners' perspective? To answer this research question, the need was to again determine the possible relationship between the physics Teachers' Technological Knowledge(TK), Content Knowledge(CK), Pedagogical Knowledge(PK), Technological Content Knowledge(TCK), Pedagogical Content Knowledge(PCK), and Technological Pedagogical Knowledge(TPK) against their Technological and Pedagogical Content Knowledge (TPCK) but from the learners' perspective. This time, Learners' Confirmation of Physics Teachers' Technological and Pedagogical Content Knowledge Questionnaire (LCTTPCKQ) was used (this time) to measure teachers' TPCK as discussed under section 3.3.2.

In order to answer research question four, the data gathered, again, was analysed quantitatively using inferential statistics. The data was analysed using correlation analysis while statistical inference was taken at 0.05 and 0.01 alpha levels. There was a positive statistically significant relationship between physics teachers' TK and TPCK, CK and TPCK, PK and TPCK, TCK and TPCK, PCK and TPCK as well as TPK and TPCK. The result as displayed in Table 4.4 as well as figure 5, shows that from the learners' perspective, the TPCK constructs with the highest positive statistically significant correlations with the TPCK are CK at .730 followed by TPK at .589, PCK at .448, and TK at .406; all at 0.01 significant level. TCK and PK are also positive statistically significant but with the least correlation coefficients of .391 and .309 respectively at significant level of 0.05.

4.3.5 Research question five

In order to answer research question five, the need was to compare the responses of the teachers on the PTTTPCKQ to their learners' responses on the LCTTPCKQ. t-Test analytic tool using SPSS was employed to determine if there was any corroboration between the learners' responses on the LCTTPCKQ and their teachers' responses on the PTTTPCKQ of the constructs of the Technological and Pedagogical Content Knowledge (TPCK) (See figure 7). The fifth research question was: Is there corroboration between the teachers' perspective and the learners' perspective on the following TPCK constructs:

- Technological Knowledge (TK),
- Content Knowledge (CK),
- Pedagogical Knowledge (PK),
- Technological Content Knowledge (TCK),

- Pedagogical Content Knowledge (PCK),
- Technological Pedagogical Knowledge (TPK) and
- Technological and Pedagogical Content Knowledge (TPCK) of the participating teachers and learners(?)

As discussed, (see section 4.2.3) and summarized in table 4.16 above, the mean values of both learners and their teachers were above 4; this indicated that they corroborated each other on all the constructs of TPCK except TCK, where it is below 4 for the learners. Yet as the significance p values of questions on all the TPCK constructs were less than (.05) except TPK, it implied that the mean values of the learners on the LCPTTPCKQ differed statistically significantly from those of their teachers on the PTTTPCKQ. This is interpreted as the difference in the means values is not being due to chance. However, the Significance p values of questions on TPK was .611 and therefore greater than (.05), and this implied that the TPK responses of the learners on the LCPTTPCKQ did not differ significantly from the TPK responses of the teachers on the PTTTPCKQ (see figure 7).

4.3.6 Research question six

The sixth research question was: What technologies do physics teachers with technological and pedagogical content knowledge use in their electricity lessons?

In order to answer this research question, the need was to find out the technologies teachers use during their teaching. The survey questionnaire we used to elicit teachers' TPCK (PTTTPCKQ) had open space provided after each question to enable teachers to substantiate

and provide more qualitative data on each question. However, as discussed under section 4.2.4, the majority of teachers did not provide the qualitative information. Hence telephone calls were made (information gathered telephonically is displayed in table 4.15). The learners of these teachers answered (LCPTTPCKQ) to confirm or reject their teachers' reported TPCCK discussed earlier. In addition, the lesson plans (Teachers Electricity Teaching Lesson Plans (TETLP)) supposed to be used by the teachers to teach electricity was also collected and analysed as discussed earlier under section 4.2.4. Table 4.17 displays information of this data. From the data analysed, the common technologies being used by a small percentage (25%) of these teachers are PhET Simulations, YouTube Videos, Power Point Presentations, Interactive White Boards, and Mindset Videos.

4.3.7 Research question seven

The seventh research question was: What sections of electricity in the CAPS physics syllabus were reported by the learners that their teachers were neglecting to teach?

In order to answer this question, the Learner Electricity Learning Confirmatory Questionnaire (LELCQ) was used to collect information about the sub-sections of the main topic electricity and analysed as discussed earlier under section 4.2.4.2.

From the analysis, it showed that 8 sections out of the 21 sections had percentages of respondents between 12.9% and 5.2% reporting that they were not taught these sections. Section 3 had the highest percentage of 12.9% followed by sections 12 at 9.3%, 21 at 8.1%, 4 at 8.0%, 19 and 20 at 5.8%, 15 at 5.5%, and section 18 had the lowest percentage of the

selected eight sub-sections of electricity at be 5.2%. The selected eight sub-sections were those sub-sections with a percentage higher than 5% (see Figure 9 and table 4.18). These sections that were reported by the learners to have been neglected by their teachers were described on the LELCQ instrument in Appendix 3 as: resistance, difference between Ohmic and non-Ohmic conductors, cost of electricity usage, and why a battery in a circuit goes flat. The others concerned solving problems involving circuits (including the concept of power), solving problems involving circuits (including the concept of electrical energy), electrical power dissipated in a device is equal to the product of the potential difference across the device and current flowing through it i.e. $P=IV$, and finally the kilowatt hour (kWh), which refers to the use of 1 kilowatt of electricity for 1 hour.

4.4 Summary of chapter

The chapter presented the results of the study, analysis of test results and analysis of the questionnaires. The seven research questions were also answered in this chapter.

CHAPTER 5

DISCUSSION OF FINDINGS

5.1 Introduction

This chapter will provide a brief account of what happened during the study and discuss the findings that were used to answer the research questions. The chapter also presents the implications of the findings.

5.2 Discussion of the Findings

The findings of the study will be discussed under this section to follow the chronology of the research questions in the study.

5.2.1 Research question one

The first research question that guided this study was: What is the relationship between physics teachers' technological and pedagogical content knowledge and their learners' achievement? As discussed earlier (see section 1.3) two studies were found to focus on in-service teachers TPCK and learner achievements (Alhababi, 2017 and Farrell and Hamed, 2017). These two studies came out with conflicting findings and therefore, recommended further studies in this area of TPCK and learner achievement. This recommendation is what motivated me to undertake this study.

From the analysis, it was shown in section 4.2 that positive statistical relationship existed between physics teachers' TPCK and their learners' achievement in the topic electricity. Yet

this relationship was not statistically significant. This finding is in line with the findings of (Farrell and Hamed, 2017). What is unique about my study is that it sought to find a relationship between teachers TPCK and learner achievement in electricity while the study by (Farrell and Hamed,2017) uses a value-added model to find relationship between teachers and their learners but not in a specific subject topic as recommended by (Jang and Tsai, 2012).

Although my finding is not statistically significant, there is a positive relationship between the teachers' TPCK and their learners' achievement. Mishra and Koehler (2006) argue that TPCK is created when teachers employ their technological knowledge, pedagogical knowledge, and content knowledge to create specific ICT-integration strategies. Teachers' ICT integration strategies reflect their consideration of content, pedagogy, learners' characteristics, and technology in relation to school and classroom context. This finding is in line with the findings of studies by Koh, Chai, Lim, (2016) who researched improvement in student learning outcomes during a teacher professional development and reported that five of the seven design teams were able to make pedagogical changes towards 21st century learning, and six of the teams experienced improvement in student learning outcomes. Koh, Chai, Wong, & Hong, (2015) stated that "Literature has recognised TPCK as a distinct type of knowledge needed for ICT-integrated lesson design". However, the focus of this study is on investigating relationship between physics teachers' TPCK and their learners' achievement. Because Jang and Tsai (2012) examined the TPCK of elementary math and science teachers in Taiwan and found that teachers with more experience had significantly higher TPCK and reported that there were no studies found that examined the TPCK of teachers by subject area and student achievement. This assertion by Jang and Tsai (2012) also energised me to undertake my study.

Hence, my study did not prescribe any particular ICT integration strategies for use in the teaching of the topic electricity in the 42 participating schools as indicated in the hypothetical model (see Figure 2 under section 2.4). It is my strong contention that if specific ICT-integration strategies were used consciously and prescribed in the current study, my investigation may have produced not only a positive relationship, but also a statistically significant relationship between physics teachers' TPCK and their learners' achievement.

5.2.2 Research question two

The second research question that guided this study was: What is the relationship between physics teachers' technological and pedagogical content knowledge and their demographics, such as age, gender, qualifications, subject majors and teaching experience? Analysis of results from table 4.2 shows that a positive, statistically significant relationship existed between physics teachers' experience and their learners' achievement as well as physics teachers' TPCK and their qualifications.

However, tables 4.3, 4.4, 4.5 and 4.6 shows that there was no statistically significant relationship between physics teachers' gender and their TPCK as well as their age and their TPCK. These findings agree with the findings of prior research, suggesting that in-service teachers' age and gender have no significant influence on their TPCK. Koh et al. (2014), Chai, Koh, Tsai, & Tan, (2011) and Lin, Tsai, Chai, Lee, (2013). But other studies found differences. In a research to find relationships between TPCK components and pre-service teacher demographics, Luik, et al. (2018) found that male pre-service students perceived their technology knowledge higher than females. They sampled 413 pre-service teachers of which

there were 355 (86.0%) female respondents and 54 (13.1%) male respondents. Haridussilm, (2016) indicated that in Estonia, only 12% of the teachers working in their institutions are males, so the gender division in the sample was in accordance with the actual situation in schools. This situation of gender disparity is consistent with this current study however we had fewer females (10%) compared to 90% males as discussed (see section 6.5). Lin et al. (2013) also indicated that gender differences exist in in-service teachers' TPCK. These contradictory results in exploring gender differences merit more investigations in future studies.

5.2.3 Research question three

The third research question that guided the study was: What is the relationship between the six TPCK constructs and the TPCK from teachers' perspective? From the analysis shown in table 4.7 and further displayed in figure 5 and 7, it shows that there were positive statistically significant relationships between all the constructs of the physics teachers' TPCK and their TPCK. The TPCK constructs were positive and statistically significant at different levels. Some of the constructs emerged as more strongly correlated than others. The constructs with the more strongly positive statistically significant correlations with the TPCK were TPK at .679 followed by TK at .577, TCK at .559, PCK at .468, and PK at .429; all at 0.01 significant level. The CK is also positive statistically significantly correlated with the TPCK but with the least correlation value of .330 at 0.05 significant level. In the TPACK framework, TCK, TPK, and TPCK represent components that describe the interactions between Shulman's general knowledge domains and technology referred to as the T - Domains; TK appears to be a unique knowledge component that is comparable to teachers' content knowledge; yet, in the case of TK, the

content refers to the technologies (Scherer, Tondeur, & Siddiq, 2017). In my study, TPK, TK and TCK correlated more, with TPCK than the rest (PCK, PK and CK) from the teachers' questionnaire. The High correlation of TPK, TK and TCK (the T – Domains) is consistent with the assertion of (Scherer et al., 2017) when they said that TK appears to be a unique knowledge component because TPCK itself is part of the T – Domains and that may be why the teachers' questionnaire TPK, TK and TCK correlated more with TPCK. Graham (2011) said researchers must work together to articulate ways that the TPCK constructs are related to each other. Angeli & Valanides (2015) further echoed this when they said that although Mishra and Koehler (2006) have described TPCK in a transformative way from the start, conceptualising TPCK as a distinct body of knowledge is not arising automatically from its adjacent sub-domains. In addition, the literature has not directly addressed the assumed relations among the seven (TK, PK, CK, TPK, TCK, PCK, and TPCK) proposed constructs. In my study, we found relationships between teachers' TK, PK, CK, TPK, TCK, PCK, and (their) TPCK. The results show in this study that all the constructs correlated positively and statistically significantly with the TPCK, with the T – Domains correlating higher with the TPCK than the others as reported earlier above.

5.2.4 Research question four

The fourth research question that guided the study was: What is the relationship between the six TPCK constructs and the TPCK from learners' perspective? As discussed in 4.3.4 above, we found relationships between physics teachers' TK, PK, CK, TPK, TCK, PCK, and their TPCK. The results show that some of the constructs of the TPCK correlate higher with the TPCK according to the responses by the teachers on the teachers' questionnaires (PTTPCKQ). This

correlation of physics teachers' TK, PK, CK, TPK, TCK, PCK, and their TPCK was done using the learners' questionnaire (LCTTPCKQ) The results, as shown in table 4.8 and also in Figure 6 and 7, were that there were positive statistically significant relationships between all the constructs of the physics teachers' TPCK and their TPCK in their learners' view. This confirmed what their teachers reported of themselves. Just like that of their teachers, some of the constructs emerged more strongly correlated than others. However, the TPCK constructs with the highest positive statistical significance correlations with the TPCK are not the T – Domains in the case of the learners' questionnaire. The correlations are mixed, with CK the highest correlated at .730 followed by TPK at .589, PCK at .448, and TK at .406; all at 0.01 significant level. TCK and PK are also positive statistically significant but with the least correlation coefficients of .391 and .309 respectively at a significant level of 0.05. The results of my study further add to already existing studies where TPCK dimensions appear to be rather mixed; comparing the teachers and learners reports on how TPCK constructs correlates with TPCK in his current study, it is evident that the correlations differ. Koehler, Mishra, Kereluik, Shin, & Graham, (2014) argued that the "high degree of correlation between the subscales of TPACK raise questions about the extent to which the components of TPACK are, in fact, separate components" (p. 106). Also, Chai, Koh, and Tsai (2016) concluded in their study on a review of the quantitative measures of Technological Pedagogical Content Knowledge, that when the factors are analysed together, construct validity for all seven factors may be problematic" (p. 90). Graham (2011) already pointed out that there are unclear boundaries between the TPACK knowledge domains and that this (still) calls for further theoretical development as well as empirical research. Voogt, Fisser, van Braak, & Tondeur, (2013) suggested in-depth studies on either the technical or the non-technical constructs of the TPCK in order to understand the nature of these constructs.

5.2.5 Research question five

The fifth research question that guided this study was: Is there a collaboration between the learners' responses on the Learners' Confirmation of Physics Teachers' Technological and Pedagogical Content Knowledge Questionnaire (LCTTPCKQ) and their teachers' responses on the Physics Teachers' Technological and Pedagogical Content Knowledge Questionnaire (PTTPCKQ) on the following seven TPCK constructs: Technological Knowledge (TK), Content Knowledge (CK), Pedagogical Knowledge (PK), Technological Content Knowledge (TCK), Pedagogical Content Knowledge (PCK), Technological Pedagogical Knowledge (TPK), and Technological and Pedagogical Content Knowledge (TPCK) of the participating teachers?

As diagrammatically represented in figure 7, and discussed earlier (see section 4.3.5), t-Test was employed to determine if there were any corroborations between the learners' responses on the LCTTPCKQ and their teachers' responses on the PTTPCKQ. From the analysis, the mean values of both learners and their teachers were above 4 (see figure 7) indicating that they corroborated each other on all the constructs of TPCK except TCK. However, as the Significance p values of questions on all the TPCK constructs were less than (.05), except TPK, it implied that the mean values of the learners on the LCPTTPCKQ differed statistically significantly from those of their teachers on the PTTPCKQ. This is interpreted as the difference in the means values not being due to chance. However, the Significance p values of questions on TPK was .611 and therefore greater than (.05), and this implied that the TPK responses of the learners on the LCPTTPCKQ did not differ significantly from the TPK responses of the teachers on the PTTPCKQ.

It was a challenge to find a study that employed these tactics of using learners to confirm or otherwise reject their teachers' reported TPCK. It is my submission that this approach is possible and may be used innovatively to elicit teachers' TPCK.

5.2.6 Research question six

The sixth research question that guided this study was: What technologies do physics teachers with technological and pedagogical content knowledge use in their electricity lessons? Analysis of results from table 4.17 (see section 4.2.4) showed that the common technologies being used by the participating teachers are PhET Simulations, YouTube Videos, Power Point Presentations, Interactive White Boards, and Mindset Videos. As discussed (see section 4.2.4 and 4.3.3), we made use of the teachers' electricity teaching lesson plans, the Doc Scientia textbook a few teachers used, the survey instruments the learners and the teachers responded to (LCTTPCKQ and PTPCKQ), and also telephonic responses from a few of the teachers in order to arrive at this result. Bilici, Guzey, & Yamak (2016) in their study, which was a TPACK-focused science methods course for pre-service teachers, also used lesson plans as well microteaching observations as data collection tools successfully in a manner as was done in my study.

It is worth mentioning that with the lesson plans collected from the teachers, it was clear that the teachers do not make a conscious effort to talk about what technologies they intend to use in their lessons, even if they do use them. Interestingly, 74% of the teacher participants indicated in their responses to PTPCKQ question 27 (Q27) that they have TPCK. Also, as

discussed under (see 4.2.3.8) and summarised in table 4.16, both of these teachers and their learners corroborated (teachers' and their learners' responses matched) each other on all the constructs of TPCK except TCK. Even though the teachers and their learners gave positive reports of teachers' TPCK, the teachers did not obviously made mention of what technologies they used in their lesson plans. In my view, this is because the format of lesson plans teachers were exposed to from their institutions of training and in-service training programmes, does not mention or create a column for technological resources to be used in the lesson even though there may be usage of technologies during the lesson deliveries. I can surmise that the teachers do not realise that technological resources used could be mentioned on the lesson plan just as other resources, such as books and study guides, calculators, chalk and chalk boards, are as resources (see Appendix 15 and 17).

5.2.6 Research question seven

The seventh research question that guided this study was: What sections of electricity in the CAPS physics syllabus did learners report their teachers were neglecting to teach? Data were collected using the Learner Electricity Learning Confirmatory Questionnaire (LELCQ) for the purposes finding out what the Grade 11 learners were taught and as well what they were not taught by their teachers during the teaching of the sections of electricity. The data collected were analysed and the results are in section 4.3.7.

As discussed earlier (see section 2.5.2), diagnostic reports on the results is released every year. From the year 2011 to 2013, the diagnostic reports indicated that content related to

electricity was poorly answered in the physical sciences paper 1 (the physics paper) (DoBE, 2011, DoBE, 2012 and DoBE, 2013). In order to improve learner achievement in this particular section of the physics paper, suggestions were made in 2014 reports that strongly pointed at training the teachers to enable them to teach the electricity section better. Some of these suggestions related to the sections in the findings of this current study.

In a study in Australia titled 'Physics Teachers' Perceptions of the Difficulty of Teaching Electricity', Gunstone, & Mulhall, (2008) reported that eight high school physics teachers interviewed were very uncertain of their own understandings of voltage/ potential/EMF, they (the eight high school teachers) went through changes of ideas as they thought about questions and were also extremely uncomfortable about this content. The researchers (Gunstone, & Mulhall) were particularly concerned that some the teachers interviewed view the topic of electricity as easy to teach even though they also view it as hard for students to learn. If teachers are uncomfortable about the content necessary to teach electricity and also perceive their learners as having difficulty learning the contents, as alluded to by (Gunstone, & Mulhall, 2008), then these might be some of the reasons why teachers in the current study neglected to teach some sections of the electricity content to the learners. The voltage/ potential mentioned by (Gunstone, & Mulhall, 2008) in their study is consistent with some of the sections neglected by the teachers in my own study.

5.3 Summary of findings

The purpose of this study was to investigate the relationship between physics teachers' Technological Pedagogical Content Knowledge (TPCK), their TK, PK, CK, TPK, TCK, PCK (TPCK constructs), their demographics, and their learners' achievement in the study of electricity as well as what technologies they use while teaching electricity. Learners were also used to investigate the relationship between physics teachers' Technological Pedagogical Content Knowledge (TPCK) and its constructs as well as the sections of electricity which their teachers had neglected to teach them. It was found that there was a positive statistical relationship between physics teachers' TPCK and their learners' achievement, yet it was not statistically significant. A positive statistically significant relationship existed between physics teachers' TPCK and its six constructs, both from learners' and teachers' perspectives. A positive statistically significant relationship also existed between physics teachers' TPCK and their experience as well as their TPCK and their learners' achievement. Physics teachers' TPCK and their qualifications also recorded a positive statistically significant relationship. However, there was no statistically significant relationship between physics teachers' gender and their TPCK as well as their age and their TPCK.

Relating to the six constructs of the TPCK, the learners' responses on the Learners' Confirmation of Physics Teachers' Technological and Pedagogical Content Knowledge Questionnaire (LCTTPCKQ) and their teachers' responses on the Physics Teachers' Technological and Pedagogical Content Knowledge Questionnaire (PTTPCKQ) were compared. It was found that the learners and their teachers corroborated each other on all the constructs of TPCK except TCK. It was also found that the common technologies being

used by those teachers with TPCK were PhET Simulations, YouTube Videos, Power Point Presentations, Interactive White Boards, and Mindset Videos. Lastly, it was also found that 8 sections of the 21 sections showed that between 12.9% and 5.2% of respondents reported that they were not taught these sections. The sections that learners reported not being taught by the teachers are: resistance, difference between Ohmic and non-Ohmic conductors, the cost of electricity usage, why a battery in a circuit goes flat, solving problems involving circuits (including the concept of power), electrical power dissipated in a device is equal to the product of the potential difference across the device and current flowing through it i.e. $P=IV$ and then finally, the kilowatt hour (kWh), which refers to the use of 1 kilowatt of electricity for 1 hour.

CHAPTER 6

CONCLUSIONS AND RECOMMENDATIONS

6.1 Introduction

This presents an overview of the study and summarises the major findings of the study and draws a conclusion upon which recommendations are made.

6.2 Overview

Many African nations are aiming at technological development so they may move away from the over dependence on natural raw resources. To achieve this, science and mathematics education must be given priority as these can affect positively on the technological development of any nation. However, achievements in science and mathematics at school level does not augur well for South Africa's urgent need for skilled personnel in engineering, science and technology. For this reason, this study investigated physics teachers' Technological Pedagogical Content Knowledge (TPCK) and their learners' achievement in the study of electricity. For this investigation, we chose electricity because it has been reported that a good number of physics teachers in South African schools find it difficult to teach electricity (see section 1.3). As stated earlier, Khine et al (2016) argue that the use of technology itself does not produce positive results in the quality of learning and students' achievement. Therefore, teachers must be competent in content knowledge, pedagogical knowledge and technological knowledge. The Technological Pedagogical Content Knowledge (TPCK) as a conceptual framework can guide teachers to understand the complex relations between the components of the TPCK framework. Therefore, the aim of this research was to

investigate physics teachers' technological and pedagogical content knowledge and their learners' achievement in the study of electricity. Hence, the seven research questions were formulated to guide this research (see section 1.5).

To answer the research questions, the study followed an explanatory mixed method research design (see section 3.2). This design makes use of a correlational study and a survey design. The design collects quantitative data where the results provide a general picture of the research problem. To better explain the general picture, more information (specifically qualitative data) was collected and analysed. The summary of these results are highlighted in section 5.3 above.

6.3 Conclusion

The findings of the study contribute to fill the gap identified by Jang and Tsai, (2012) and recently re-echoed by Farrell & Hamed, (2017) when they recommended that studies in TPCK and learner achievement in specific topics should be conducted. The findings of the study showed that there was a positive, statistically significant relationship between physics teachers' experience and their learners' achievement, physics teachers' TPCK and their TK, PK, CK, TPK, TCK and PCK as well as physics teachers' TPCK and their qualifications. This study has therefore confirmed the saying: "Experience is the best teacher" as the more experienced teachers' learners' achieved better in the LEAT test, and the most qualified teachers in the sample have higher TPCK, which indicates that teachers with higher TPCK produced learners who achieved better in the test. A positive statistical relationship between physics teachers' TPCK and their learners' achievement was also found as a result of this study, but this finding

was not statistically significant. Even though the relation between the physics teachers' TPCK and learners' achievement was not statistically significant, it emerged that it could also be a factor, much like physics teachers' experience and their qualifications. Studies such as Kriek & Stols, (2010) and Stols, Kriek & Ogbonnaya, (2008) have shown that learners' achievement is related to teachers' instructional practices. However, the study found no statistically significant relationship between physics teachers' gender and their TPCK as well as their age and their TPCK.

The study also found that the common technologies being used by a small percentage (25%) of the participating teachers to teach were PhET Simulations, YouTube Videos, Power Point Presentations, Interactive White Boards, and Mindset Videos. The teachers did not indicate these in their teaching lesson plans as expected, but a few of them indicated using some of these technologies when they answered the PTTCKQ. For some, the technologies they were using was revealed through telephonic questioning and for others, the textbook they had indicated using in their lesson plans had some features such the QR bar codes. As discussed earlier (see section 4.2.4.1). In general, it appears many of teachers do not consciously plan to use certain technologies before they go to class hence, they do not indicate it on their lesson plans, even if they end up using them. This notwithstanding, there is evidence that the teachers use technologies, as it was found in the study that the learners and their teachers corroborated each other on all the constructs of TPCK except TCK. These are the teachers out of the 42 teachers who indicated that they do have TPCK when they answered the PTTCKQ (question 27 (Q27)). The study also found that teaching a few of the sections of electricity were being neglected by the teachers. These sections were: resistance, difference between Ohmic and non-Ohmic conductors, the cost of electricity usage, why a battery in a circuit goes

flat, solving problems involving circuits (including the concept of power), electrical power dissipated in a device is equal to the product of the potential difference across the device and current flowing through it i.e. $P=IV$ and then finally, the kilowatt hour (kWh), which refers to the use of 1 kilowatt of electricity for 1 hour.

6.4 Recommendations

Technological Pedagogical Content Knowledge (TPCK) is crucial for efficient teaching with technologies therefore teacher education programmes should provide pre-service teachers with opportunities to develop their TPCK so that they can successfully incorporate technology into their teaching. These teacher education programmes should help develop lesson plan templates that will train teachers to consciously plan with technology integration in mind and indicate this in their lesson plans. Stols & Kriek, (2011), Oh & Reeves, 2014 and Koh, et al (2015) in their studies made similar recommendations. They recommended that the teacher training programmes of the Universities be updated to equip new teachers with the required knowledge and skills to handle computer-based teaching effectively. Also, in-service training programmes need to be organised for newly appointed teachers using experienced serving teachers whose experience the newly appointed teachers can tap into and ultimately bring about learner achievement as hypothesised by this study (see section 2.4). Teacher experience was found to have a statistically significance relationship with learners' achievement in this study.

Even though there is evidence found as a result of this study that the teachers have TPCK, they did not indicate what technologies they would use in their electricity lesson plans. This

evidence emanated from the teachers themselves reporting their TPCK (76%) (see section 4.2.4) as well as the learners corroborating their teachers on all the constructs of TPCK except TCK. It is therefore recommended that the Department of Education liaise with other relevant stakeholders in education to help teachers to develop a consciousness of technological integration when planning their lessons. Also, the department should develop more teaching resources using common technologies the teachers in this study indicated using during their lessons (PhET Simulations, YouTube Videos, Power Point Presentations, Interactive White Boards, and Mindset Videos) and even more. These technologies should be made readily available and accessible to the teachers to plan with and to integrate them in their teaching on a regular basis.

6.5 Recommendations for future research

It is my belief that there are many further investigations that can be developed from my study. It is for this reason that we would like to point out a few possible avenues in an attempt to precipitate other researchers to use my research as their starting point. We recommend that further studies investigate the relationship between physics teachers' TPCK and learners' achievement using other topics in physics such as electrostatics, electromagnetism, photoelectric effect and other topics, which may seem too abstract to teach without real teaching and learning materials.

This study did not provide information on which of the TPCK constructs contributed the most in terms of integrating technologies and promoting learner achievement the specific topic electricity. In this regard, the contribution of the specific constructs towards learner

achievement specialised subjects (topics) still need to be determined by future researchers developing designs, which could prescribe particular technology integration interventions in future.

Self-reported items measured physics teachers' TPCK as well as the constructs of the TPCK. Their learners were used to check for possible confirmation or otherwise. We recommend that in future, an investigation to determine the extent to which these self-reports are susceptible and sensitive to response partiality – evident in a case of overrating or simply agreeing with any positive prompt. We therefore encourage researchers to examine the extent to which the TPCK self-efficacy measure corresponds to an actual performance-based measure for more samples of both pre-service and in-service teachers.

Future research may also repeat this study using grades other than grade 11 to see if similar results will emerge. Attention should also be paid to gender equity in the sampling of the teacher participants in future studies. From this study, it appears that male teachers mostly teach physics. Even though purposive sampling was used to select the Nkangala region, the sampling of the 42 schools in the region was random. As discussed earlier (see section 4.2.1 and 5.2.2), that of the 42 teachers who participated, only 4 (10%) were females. This is consistent with study of (Luik, et. Al., 2018) discussed earlier. Only 10% female teachers participated because, it was found after data collection that Nkangala educational region is divided in to four circuits currently and table 6.1 shows the physical science teacher distribution across the circuits by gender. Of these four circuits the research data was mostly collected from KwaMhlanga and Morelete where the female teacher populations were 20% and 26% respectively because of proximity to the researcher.

Table 6:0:1 Distribution of the physical science teachers by gender in the four circuits of the Nkangala educational region (Source: Nkangala Regional Education Office)

Circuits	Male		Female	
	Number	%	Number	%
KwaMhanga	46	79	12	20
Siyabuswa	35	56	27	44
Emalahleni	32	57	24	42
Morelete	28	73	10	26
Total	141	66	73	34

Therefore, with hindsight, it is suggested that future studies should employ sampling techniques that will be sensitive to gender representation in order to increase the number of female teachers participating.

We are suggesting also that future research should develop a lesson template which provides for a column for technology integration under the heading ‘resources and name’ as well as the heading ‘technological tools or resources’ to determine what technologies the teachers use in the delivery of their lessons. This will help teachers to consciously think of technology integration during the planning stages of the lesson and help researchers to easily identify which technologies the teachers are thinking of using in their lessons.

Other methods could be used to gather information about the technologies physics teachers used in their lesson delivery. These may include, but are not limited to, lesson observation and using video recorders to record the lessons, then analysing the videos later to collect the required information. To verify the statistical data, qualitative data may be gathered through interviews. These methods could yield concrete evidence of what technologies physics teachers with TPCK in a study like this used during their lesson delivery. Hence, we recommend that researchers who wish to extend this study look at how to innovatively make

use of a few of these methods, in addition to my methods, or even in isolation in order to collect data.

REFERENCES

- AACTE Committee on Innovation and Technology (Ed.), (2008). *The Handbook of Technological Pedagogical Content Knowledge (TPCK) for Educators*. Routledge. 363 pages.
- Abbitt, J.T. (2011). Measuring Technological Pedagogical Content Knowledge in Preservice Teacher Education, *Journal of Research on Technology in Education*, 43:4, 281-300, DOI: 10.1080/15391523.2011.10782573
- Alev, N., Karal-Eyuboglu, I.S., & Yigit, N. (2012). Examining pre-service physics teachers' pedagogical content knowledge (PCK) with Web 2.0 through designing teaching activities. *Procedia - Social and Behavioral Sciences* 46 (2012) 5040 – 5044
- Alhababi, H. H. (2017). "Technological Pedagogical Content Knowledge (Tpack) Effectiveness on English Teachers and Students in Saudi Arabia". *Dissertations*. 456. <https://digscholarship.unco.edu/dissertations/456>
- Al-Hariri MT, Al-Hattami AA. (2017). Impact of students' use of technology on their learning achievements in physiology courses at the University of Dammam. *J Taibah Univ Med Sc* 2017;12(1): 82e85.
- Anderson, L. W. (2004). *Increasing teacher effectiveness*. (2nd ed.). Paris: UNESCO International Institute for Educational Planning. <http://www.unesco.org/iiep>
- Anderson, R.D. (2002). Reforming science teaching: What research says about inquiry. *Journal of Science Teacher Education*, 13(1), 1-12.
- Archambault, L. M., & Barnett, J. H. (2010). Revisiting technological pedagogical content knowledge: Exploring the TPACK framework. *Computers & Education*, 55(4), 1656-1662. doi:10.1016/j.compedu.2010.07.009
- Archambault, L., & Crippen, K. (2009). Examining TPACK among K-12 online distance educators in the United States. *Contemporary Issues in Technology and Teacher Education*, 9(1). Retrieved from <http://www.citejournal.org/vol9/iss1/general/article2.cfm>

- Atagana, H.I., Mogari, L.D., Kriek, J., Ochonogor, E.C., Ogbonnaya, U.I., Dlamini, J.J. & Makwakwa, E.G. (2010). An intervention into educators' and learners' difficulties in some topics in mathematics, science and technology: a report of ISTE 2010 Winter School. *A research report*. Pretoria: Unisa.
- Berger, J.L., Girardet, C., Vaudroz, C. & Crahay, M. (2018). Teaching Experience, Teachers' Beliefs, and Self-Reported Classroom Management Practices: A Coherent Network. *SAGE open*, 8(1), 1-12.
- Bernardo, R., du Plessis, H., du Plessis, S., Fanoy, S., Jones, E., Lees – Rolfe, P., Reynecke, J.M.K., Schmidt, M., Smith, L. (2015). *Doc Scientia Physics Test and Workbook. Grade 11 Physical Sciences*. Doc Scientia Press, pp. 256 – 304, ISBN 978-1-920537-16-6
- Betts, J. R., Zau, A. C., & Rice, L.A. (2003). Determinants of student achievement: New Evidence from San Diego. San Francisco, CA: Public Policy Institute of California.
- Bilici, S. C., Guzey, S. S., & Yamak, H. (2016). Assessing pre-service science teachers' technological pedagogical content knowledge (TPACK) through observations and lesson plans. *Research in Science & Technological Education* Vol. 34(2) 237-251
- Blumberg, B., Cooper, D.R., Schindler, P.S. (2008). *Business Research Methods*. (2nd.ed.) London: McGraw-Hill.
- Buddin, R. & Zamarro, G. (2009). What Teacher Characteristics Affect Student Achievement? Findings from Los Angeles Public Schools. *Journal of Urban Economics*, Vol. 66, No. 2, September 2009, pp. 103–115; available as RP-1410 at <http://www.rand>.
- Chai, C. S., Koh, J. H. L., & Tsai, C. C. (2016). A review of the quantitative measures of Technological Pedagogical Content Knowledge (TPACK). In M. C. Herring, M. J. Koehler, & P. Mishra (Eds.), *Handbook of Technological Pedagogical Content Knowledge (TPACK) for Educators* (2 ed., pp. 87 106). New York, London: Taylor & Francis.
- Chai, C.-S., Koh, J. H.L., & Tsai, C.C. (2013). A Review of Technological Pedagogical Content Knowledge. *Educational Technology & Society*, 16 (2), 31–51.

- Chai, C.S., Koh, J.H.L., Tsai, C.C. (2010). Facilitating preservice teachers' development of technological, pedagogical, and content knowledge (TPACK). *Educ Technol Soc* 13 (4), 63–73
- Chai, C.S., Koh, J.H.L., Tsai, C.C., Tan, L.W.L. (2011). Modelling primary school pre-service teachers' Technological Pedagogical Content Knowledge (TPACK) for meaningful learning with information and communication technology (ICT). *Computer Education* 57(1):1184–1193. doi:10.1016/j.compedu.2011.01.007
- Chan, H, N. (2010). *How do teachers' beliefs affect the implementation of inquiry-based learning in the PGS Curriculum? A case study of two primary schools in Hong Kong.* Doctoral thesis, Durham: Durham University.
- Chin, C. & Kayalvizhi, G. (2002). Posing questions for open investigations: What questions do pupils ask? *Research in Science & Technological Education*, 20(2), 269-287. Cohen, L., Manion, L., & Morrison, K. (2007). *Research Methods in Education*. (6th ed.) New York: Routledge.
- Cox, S. (2008). *A conceptual analysis of technological pedagogical content knowledge* (Doctoral dissertation). Retrieved from ProQuest Dissertations and Theses database. (UMI No. 3318618)
- Cox, S., Graham, C.R. (2009) Diagramming TPACK in practice: using an elaborated model of the TPACK framework to analyse and depict teacher knowledge. *Tech Trends* 53(5):61
- Creswell, J. W. (2015). *A Concise Introduction to Mixed methods research*. (5th ed.) California: SAGE Inc.
- Cuban, L. (2001). *Oversold and underused: Computers in the classroom*. Cambridge: Harvard University Press.
- Darling-Hammond, L., Herman, J., Pellegrino, J., et al. (2013). Criteria for high-quality assessment. Stanford, CA: Stanford Center for Opportunity Policy in Education.

- Dega, B., Kriek, J., & Mogese, T. (2013). Students' Conceptual Change in Electricity and Magnetism using Simulations: A Comparison of Cognitive Perturbation and Cognitive Conflict. *Journal of Research in Science Teaching* 50(6), 677-698. Doi: 10.1002/tea.21096.
- Dega, B.G. (2012). *Conceptual Change through Cognitive Perturbation using Simulations in Electricity and Magnetism: A Case Study in Ambo University, Ethiopia*. Unpublished doctoral thesis, of the University of South Africa, Pretoria.
- DoBE (Department of Basic Education) (2011a). *Curriculum and Assessment Policy Statement (CAPS) Grades 10-12: Physical Sciences*. Department of Basic Education.
- DoBE (Department of Basic Education) (2011b). *Report on the National Senior Certificate Examination: National diagnostic report on learner performance*. Pretoria: Department of Basic Education.
- DoBE, (Department of Basic Education) (2014). *Report on the National Senior Certificate Examination: National diagnostic report on learner performance*. Pretoria: Department of Basic Education.
- DoBE (Department of Basic Education) (2015). *National Senior Certificate Examination report*: Pretoria: Department of Basic Education.
- DoBE (Department of Basic Education) (2016). *National Senior Certificate Examination report*: Pretoria: Department of Basic Education.
- DoE (Department of Education) (1995). *White Paper on Education and Training*, 15 March, Department of Education, Cape Town.
- DoE (Department of Education) (2003). "Review of the Financing, Resourcing and Cost of Education in Public Schools", *Government Gazette*, Vol. 543, 14 March, Department of Education, Pretoria
- DoE (Department of Education) (2005). *Guidelines for Inclusive Learning Programmes*, Department of Education, Pretoria.

- Doering, A., & Veletsianos, G. (2007). An investigation of the use of real-time, authentic geospatial data in the k-12 classroom. *Journal of Geography*, 106(6), 217–225.
- Doering, A., Veletsianos, G., Scharber, C., & Miller, C. (2009). Using the technological, pedagogical, and content knowledge framework to design online learning environments and professional development. *Journal of Educational Computing Research*, 41(3), 319–346. doi:10.2190/EC.41.3.d.
- Donmeza, G., Basturka, S. (2010). Pre-service mathematical teachers' knowledge of different teaching methods of the limit and continuity concept. *Procedia Social and Behavioral Sciences* 2, 462–465
- DoS (Department of Statistics). (2011). Mid-year population estimate. Pretoria: Department of Statistics.
- Erdogan, A., & Sahin, I. (2010). Relationship between math teacher candidates' technological pedagogical and content knowledge (TPACK) and achievement levels. *Procedia—Social and Behavioral Sciences*, 2(2), 2707–2711.
- Farrell, I.K. & Hamed, K.M. (2017) Examining the Relationship Between Technological Pedagogical Content Knowledge (TPACK) and Student Achievement Utilizing the Florida Value-Added Model, *Journal of Research on Technology in Education*, 49:3-4, 161-181, DOI: 10.1080/15391523.2017.1328992
- Forsell, K.S. (2011). *Technological Pedagogical Content Knowledge: Relationships to Learning Ecologies and Social Learning Networks*. Unpublished doctoral thesis, of the Stanford University, Stanford California.
- Gay, L.R., & Airasian, P. (2003). *Educational Research: Competencies for analysis and application* (7th ed.). Columbus: Merrill, Prentice Hall.
- Gess-Newsome, J. (2015). A model of teacher professional knowledge and skill including PCK. In A. Berry, P. Friedrichsen, & J. Loughran (Eds.), *Re-examining pedagogical content knowledge in science education* (pp. 28-42). New York, NY: Routledge.
- Graham, C. R. (2011). Theoretical considerations for understanding technological pedagogical content knowledge (TPACK). *Computers & Education*, 57, 1953–1960.

- Green, S. (2013). *Assessment is essential* (11th ed.) Content Technologies Inc.
- Gunstone, R., Mulhall, P.J. (2008). Physics Teachers' Perceptions of the Difficulty of Teaching Electricity. *Research in Science Education*, 39, 515–538.
- Han, I., Eom, M., & Shin, W.S. (2011). Multimedia case-based learning to enhance pre-service teachers' knowledge integration for teaching with technologies. *Teaching and Teacher Education* 34, 122 – 129
- Hashweh, M. Z. (2005). Teacher pedagogical constructions: A reconfiguration of pedagogical content knowledge. *Teachers and Teaching: Theory and Practice*, 11(3), 273-292. doi:10.1080/13450600500105502
- Hofer, M. J. and Harris, J. (2012). "TPACK Research with Inservice Teachers: Where's the TCK?" *Book Chapters*. 9. <https://scholarworks.wm.edu/bookchapters/9>
- Hsu, C.-Y., Tsai, M.-J., Chang, Y.-H., & Liang, J.-C. (2017). Surveying In-Service Teachers' Beliefs about Game-Based Learning and Perceptions of Technological Pedagogical and Content Knowledge of Games. *Educational Technology & Society*, 20 (1), 134–143
- Jang, S.J. & Tsai, M. F. (2012). Exploring the TPACK of Taiwanese elementary mathematics and science teachers with respect to use of interactive whiteboards. *Computers & Education* 59, 327–338
- Jang, S.J. & Tsai, M. F. (2012). Exploring the TPACK of Taiwanese elementary mathematics and science teachers with respect to use of interactive whiteboards. *Computers & Education* 59, 327–338
- Jang, S.J., Tsai, M.F. (2012). Exploring the TPACK of Taiwanese elementary mathematics and science teachers with respect to use of interactive whiteboards. *Computers & Education* 59 (2012) 327–338
- Khine, M.S., Ali, N. & Afari, E. (2016). Exploring relationships among TPACK constructs and ICT achievement among trainee teachers. *Education and Information Technologies*, 22(1) 1573-7608

- Kocuglu, (2009). Exploring the technological pedagogical content knowledge of pre-service teachers in language education. *Procedia - Social and Behavioural Sciences* 1 (2009) 2734–2737
- Koehler, M. J., & Mishra, P. (2009). What is technological pedagogical content knowledge? *Contemporary Issues in Technology and Teacher Education*, 9(1), 60-70.
- Koehler, M. J., Mishra, P., Kereluik, K., Shin, T. S., & Graham, C. R. (2014). The Technological Pedagogical Content Knowledge Framework. In M. J. Spector, D. M. Merrill, J. Elen, & J. M. Bishop (Eds.), *Handbook of Research on Educational Communications and Technology* (pp. 101-111). New York, NY: Springer.
- Koh, J. H. L., Chai, C. L., Lim, W. Y. (2016). Teacher Professional Development for TPACK-21CL Effects on Teacher ICT Integration and Student Outcomes. *Journal of Educational Computing Research* Vol 55, Issue 2, pp. 172 - 196 10.1177/0735633116656848
- Koh, J. H. L., Chai, C. S., & Tsai, C.-C. (2014). Demographic factors, TPACK constructs, and teachers' perceptions of constructivist-oriented TPACK. *Journal of Educational Technology & Society*, 17(1), 185-196.
- Koh, J. H. L., Chai, C. S., Wong, B., & Hong, H.- Y. (2015). Technological Pedagogical Content Knowledge (TPACK) and design thinking: A framework to support ICT lesson design for 21st century learning. *The Asia-Pacific Education Researcher*, 24(3), 535-543. <http://dx.doi.org/10.1007/s40299-015-0237-2>
- Koh, J. L., Chai, C. S., & Tsai, C. C. (2010). Examining the technological pedagogical content knowledge of Singapore preservice teachers with a large-scale survey. *Journal of Computer Assisted Learning*, 26(6), 563-573. doi:10.1111/j.13652729.2010.00372.x
- Kopcha, T. J., Ottenbreit-Leftwich, A., Jung, J., & Baser, D. (2014). Examining the TPACK framework through the convergent and discriminant validity of two measures. *Computers & Education*, 78, 87-96. doi:10.1016/j.compedu.2014.05.003

- Kotoka, J. & Kriek, J. (2014) The Impact of Computer Simulations as Interactive Demonstration Tools on the Performance of Grade 11 Learners in Electromagnetism, *African Journal of Research in Mathematics, Science and Technology Education*, 18:1, 100-110, DOI: 10.1080/10288457.2014.884263.
- Kriek J and Basson, I (2008). Implementation of the new FET Physical Sciences curriculum: teachers' perspectives. *African Journal of Research in Mathematics, Science and Technology Education*, 12, pp.63 – 76
- Kriek, J., & Stols, G. (2010). Teachers' beliefs and their intention to use interactive simulations in their classrooms. *South African Journal of Education*, 30, 439-456.
- Krauskopf, K., Carmen Zahn, C., & Hesse, F.W. (2012). Leveraging the affordances of YouTube: The role of pedagogical knowledge and mental models of technology functions for lesson planning with technology. *Computers & Education* 58 1194–1206
- Kurt, S. (2018). "Technological Pedagogical Content Knowledge (TPACK) Framework," in *Educational Technology*. Retrieved in may from: <https://educationaltechnology.net/technological-pedagogical-content-knowledge-tpack-framework/>
- Kwanda, M., Kriek, J., Basson, I., & Lemmer, M. (2011). An investigation of pre-service teachers' conceptual understanding of basic DC circuits. In D. Mogari, U. Ogbonnaya, K. Padayachee (Eds.) *ISTE International Conference Proceedings* (pp. 294 - 308). Pretoria: UNISA Press.
- Lee, M., & Tsai, C. (2010). Exploring teachers' perceived self-efficacy and technological pedagogical content knowledge with respect to educational use of the world wide web. *Instructional Science: An International Journal of the Learning Sciences*, 38(1), 1-21.
- Lee, Y. (2011). Enhancing pedagogical content knowledge in a collaborative school-based professional development program for inquiry-based science teaching. *Asia-Pacific Forum on Science Learning and Teaching*, 12(2), 1-29.
- Lin, T. C., Tsai, C. C., Chai, C. S., Lee, M. H. (2013). Identifying Science Teachers' Perceptions of Technological Pedagogical and Content Knowledge (TPACK). *J Sci Educ Technol* 22: 325. doi:10.1007/s10956-012-9396-6

- Lin, T.C., Tsai, C.C., Chai, C.S., & Lee, M.H. (2012). Identifying Science Teachers' Perceptions of Technological Pedagogical and Content Knowledge (TPACK). *J Sci Educ Technol* DOI 10.1007/s10956-012-9396-6
- Loughran, J., Berry, A., & Mulhall, P. (2012). *Understanding and developing science teachers' pedagogical content knowledge*. Netherlands: Sense Publishers.
- Luik, P., Taimalu, M. & Suviste, R. (2018). Perceptions of technological, pedagogical and content knowledge (TPACK) among pre-service teachers in Estonia. *Education and Information Technologies* 23: 741. <https://doi.org/10.1007/s10639-017-9633-y>
- Mamutse, K. & Ramnarian, U. (2014). Exploring the use of improvised physical resources in the implementation of inquiry-based science teaching and learning in grade 9 natural sciences. In D. Mogari, U. Ogbonnaya, K. Padayachee (Eds.) *ISTE International Conference Proceedings* (pp. 212 - 220). Pretoria: UNISA Press.
- Maree, J.G.K. (2010). Critical Appraisal of the System of Education and Prospects of Meeting the Manpower and Developmental Needs of South Africa. *Africa insight* 40 (2), 85 – 108.
- Mathers, C. Oliva, M. & Laine, S. W. M, (2008). Improving instruction through effective teacher evaluation: Options for states and districts. Washington, DC: National comprehensive center for teacher quality.
- Mishra, P., & Koehler, M. J. (2006). Technological pedagogical content knowledge: A framework for integrating technology in teachers' knowledge. *Teachers College Record*, 108(6), 1017–1054.
- Mji, A., & Makgato, M., (2006). Factors associated with high school learners' poor performance: a spotlight on mathematics and physical science. *South African Journal of Education*, 26 (2), 253-266.
- National Research Council. (1999). *Being fluent with information technology literacy. Computer science and telecommunications board commission on physical sciences, mathematics, and applications*. Washington, DC: National Academy Press.

- Niess, M. (2008). Mathematics Teachers Developing Technology, Pedagogy and Content Knowledge (TPACK). In K. McFerrin et al. (Eds.), *Proceedings of Society for Information Technology & Teacher Education International Conference 2008* (pp. 5297-5304). Chesapeake, VA: AACE
- Nyanhi, G.M. & Ochonogor, C.E. (2014). conceptual implications of sub-microscopic representations of basic chemical concepts: Novice physical science learners' views. In D. Mogari, U. Ogbonnaya, K. Padayachee (Eds.) *ISTE International Conference Proceedings* (pp. 292 - 309). Pretoria: UNISA Press.
- Nilsson, P. (2008). Teaching for understanding: The complex nature of pedagogical content knowledge in preservice education. *International Journal of Science Education*, 30(10), 1281-1299. doi:10.1080/09500690802186993
- Nyanhi, G.M., & Ochonogor, C.E. (2014). Conceptual implications of sub-microscopic representations of basic chemical concepts: Novice physical science learners' views. In D. Mogari, U. Ogbonnaya, K. Padayachee (Eds.) *ISTE International Conference Proceedings* (pp. 292 - 209). Pretoria: UNISA Press.
- OECD (2008), *Reviews of National Policies for Education: South Africa*, OECD, Paris. www.oecd.org/publishing/corrigenda
- Ogbonnaya, U. I. (2011). *Exploring the relationship between mathematics teachers' subject matter knowledge and their teaching effectiveness*. Unpublished doctoral thesis, of the University of South Africa, Pretoria.
- Ogbonnaya, U. I. (2007). *The influence of teachers' background, professional development and teaching practices on students' achievement in mathematics in Lesotho*. Unpublished Masters Dissertation, of University of South Africa, Pretoria.
- Oh, E., & Reeves, T. C. (2014). Generational differences and the integration of technology in learning, instruction, and performance. In *Handbook of research on educational communications and technology* (pp. 819-828). New York, NY: Springer.

- Pandor, N., (2010). Speech by Minister Naledi Pandor, MP, at the 12th National Science and Technology Forum Awards, Johannesburg. 4 May.
- Prescott, A., Bausch, I., Bruder, R. (2013). TELPS: A method for analysing mathematics pre-service teachers' Pedagogical Content Knowledge. *Teaching and Teacher Education* 35, 43 – 50
- Ramnarain, U. (2010). Teaching Scientific Investigations. Cape Town: Macmillan.
- Rice, J.K. (2010). The Impact of Teacher Experience: Examining the Evidence and Policy Implications. *Research brief for the Center for Longitudinal Data in Education Research*. Washington DC: The Urban Institute.
- Rice, A.H., & Kitchel, T. (2016). Influence of Knowledge of Content and Students on Beginning Agriculture Teachers' Approaches to Teaching Content. *Journal of Agricultural Education*, 57(4), 86-100. <https://doi.org/10.5032/jae.2016.04086>
- Rivkin, S. G., Hanushek, E. A., & Kain, J. F. (2005). Teachers' schools and academic achievement. *Econometrica*, 73 (2), 417-458.
- Rutten, N., van Joolingen, W. R., & van der Veen, J. T. (2012). The learning effects of computer simulations in science education. *Computers & Education*, 58(1), 136-153.
- Sahin, I. (2011). Development of survey of technological pedagogical and content knowledge (TPACK). *Turkish Online Journal of Educational Technology*, 10(1), 97-105.
- Sahin, S. (2012). Pre-service teachers' perspectives of the diffusion of information and communications technologies (ICTs) and the effect of case-based discussions (CBDs). *Computers and Education*, 59, 1089 - 1098.
- Scherer, R., Tondeur, J., & Siddiq, F. (2017). On the quest for validity: Testing the factor structure and measurement invariance of the technology-dimensions in the Technological, Pedagogical, and Content Knowledge (TPACK) model. *Computers & Education*, 112, 1-17. doi: 10.1016/j.compedu.2017.04.012

- Schmidt, D.A., Baran, C., Thompson, A.D., Mishra, P., Koeler, M.J. & Shin, T.S. (2009). Technological Pedagogical Content Knowledge (TPACK): The Development and Validation of an Assessment Instrument for Pre - service Teachers. *Journal of Research on Technology in Education*. 42(2), 123–149
- Scott C., L. (2015). *THE FUTURES of LEARNING 3: What kind of pedagogies for the 21st century?* UNESCO Education Research and Foresight, Paris. [ERF Working Papers Series, No. 15].
- Sheffield, R., Dobozy, E., Gibson, D., Mullaney, J. & Campbell, C. (2015). Teacher education students using TPACK in science: a case study. *Educational Media International*, DOI: 10.1080/09523987.2015.1075104
- Smart, V. L. (2016). *Technological Pedagogical Reasoning: The development of teachers pedagogical reasoning with technology over multiple career stages* Unpublished doctoral thesis, of Griffith University, Queensland.
- Shulman, L. S. (1986). Those who understand: Knowledge growth in teaching. *Educational Researcher*, 15(2), 4-14.
- Shulman, L. S. (1987). Knowledge and teaching: Foundations of the new reform. *Harvard Educational Review*, 57(1), 1-22.
- Stavrinides, S. G., Taramopoulos, A., Hatzikraniotis, E., & Psillos, D. (2015). *ICT-enhanced teaching of electrical circuits. 4th system technologies*. International Conference on modern circuit and system technologies.
- Stols, G., & Kriek, J. (2011). Why don't all maths teachers use dynamic geometry software in their classrooms? *Australasian Journal of Educational Technology*. 27(1), 137-151.
- Stols, G., Kriek, J. & Ogbonnaya, U. I., (2008). The relationship between teaching practices and students' achievement in mathematics in Lesotho. *African Journal of Research in Mathematics, Science and Technology Education*, 12, 107-118.

- Tambara, C.T. (2015). Unpacking teachers' pedagogical content knowledge and skills to develop learners' problem-solving skills in mathematics. Unpublished Doctoral Thesis. Stellenbosch: Stellenbosch University.
- Thompson, A., & Mishra, P. (2007). Breaking news: TPCK becomes TPACK! *Journal of Computing in Teacher Education*, 24(2), 38–64.
- Voogt, J., Fisser, P., van Braak, J., & Tondeur, J. (2013). *Unraveling the TPACK model: finding TPACK-Core*. Paper presented at the Annual Conference of the Society for Information Technology and Teacher Education (SITE), New Orleans.
- Ward, A., Stoker, H.W., Murray-Ward, M. (1996), "*Achievement and Ability Tests – Definition of the Domain*", *Educational Measurement 2*, University Press of America, pp. 2–5, ISBN 978-0-7618-0385-0
- Webb, M., & Cox, M. (2004). A review of pedagogy related to Information and Communications Technology. *Technology. Pedagogy and Education*, 13(3), 235–286.
- Welman, C., Kruger, F., & Mitchell, B. (2005). *Research methodology* (3rd ed.) Cape Town: Oxford University Press Southern Africa.

APPENDICES

Appendix 1

Physics Teachers' Technological and Pedagogical Content Knowledge Questionnaire (PTTPCKQ)

Dear Grade 11 Physics Teacher,

I am Mr. Kotoka J.K, a student in the Department of Mathematics, Science and Technology Education in the University of South Africa (UNISA). I am interested in investigating the link between Physics teachers' technological and pedagogical content knowledge and their learners' performance in electricity.

The following questionnaire is aimed at obtaining information about your teaching of Physics (electricity) in Grade11. Your response will be anonymous, and the information gathered will help us improve the teaching of Physics and also help our learners to perform better in Physics. I would appreciate your completion of the questionnaire. I understand your schedule is very busy. However, I hope that the 15 to 20 minutes it will take you will help us understand how to improve the teaching of Physics in South Africa.

Thank you in advance for your participation. If you have any question about the study or any of items in the questionnaire, call me on 0734639661 or 012 3333 712.

Yours sincerely,

Kotoka J.K.

Directions

1. This questionnaire requires you to rate your Technological and Pedagogical Content Knowledge in teaching Grade 11 Physics this academic year based on the extent of your agreement or disagreement with the statements.
2. Please give an answer/rating to every question/statement.

Section A. Demographic Information

Thank you for taking time to complete this questionnaire. Please answer each question to the best of your knowledge. Your thoughtfulness and candid responses will be greatly appreciated. Your individual name or identification number will not at any time be associated with your responses. Your responses will be kept completely confidential.

1. Teacher Code:
2. School Code:
3. Age range (Years):
 20 – 25, 26 – 30, 31 – 35,
 36 – 40, 41+
4. Gender:
 Male
 Female
5. How many years have you taught Physics at FET band?
 0 – 5 years, 6 – 10 years, 11 –15 years
 16 –20 years, Over 20 years
6. Qualification(s):
7. Subject specialisation:

Section B. Teachers’ Technological and Pedagogical Content Knowledge

Technology is a broad concept that can mean a lot of different things. For the purpose of this questionnaire, technology is referring to digital technology/technologies. That is, the digital tools we use such as computers, laptops, iPods, handhelds, interactive whiteboards, software programs, etc. Please answer all of the questions.

Instructions: For sections B use the codes given, by writing a code (e.g. 1, 2, 3, 4, 5 or 6) of your choice against the questions. The codes are given below. For each statement, give reason(s) for the choice made on the space provided where necessary.

Strongly Disagree = 1	Disagree = 2	Slightly Disagree = 3	Slightly Agree = 4	Agree = 5	Strongly Agree = 6
--------------------------	--------------	--------------------------	-----------------------	-----------	-----------------------

1 I know how to solve my own technical problems.

2 I can learn technology easily.

3 I frequently play around with the technology.

4 I know about a lot of different technologies.

5 I have the technical skills I need to use technology.

6 I have sufficient knowledge about physics.

7 I can use a scientific way of thinking.

8 I have various ways and strategies of developing my understanding of physics.

9 I know how to assess student performance in a classroom. Give examples

- 10 I can adapt my teaching based-upon what students currently understand or do not understand.
-
-
- 11 I can adapt my teaching style to different learners.
-
-
- 12 I can assess student learning in multiple ways. Give examples.
-
-
- 13 I can use a wide range of teaching approaches in a classroom setting.
-
-
- 14 I am familiar with common student understandings and misconceptions. Eg weakening current and shared current misconceptions
-
-
- 15 I know how to organize and maintain classroom management.
-
-
- 16 I can select effective teaching approaches to guide student thinking and learning in physics.
-
-
- 17 I know about technologies that I can use for understanding and doing physics.
-
-
- 18 I can choose technologies that enhance the teaching approaches for a lesson.
-
-
- 19 I can choose technologies that enhance learners' learning for a lesson.
-
-

20 My teacher education program has caused me to think more deeply about how technology could influence the teaching approaches I use in my classroom.

21 I am thinking critically about how to use technology in my classroom.

22 I can adapt the use of the technologies that I am learning about to different teaching activities.

23 I can select technologies to use in my classroom that enhance what I teach, how I teach and what students learn.

24 I can use strategies that combine content, technologies and teaching approaches that I learned about in my coursework in my classroom.

25 I can provide leadership in helping others to coordinate the use of content, technologies and teaching approaches at my school.

26 I can choose technologies that enhance the content for a lesson.

27 I can teach physics lessons that appropriately combine technologies and teaching approaches.

Appendix 2

Learners' Confirmation of Physic Teachers' Technological and Pedagogical Content Knowledge Questionnaire (LCPTTPCKQ)

Dear Grade 11 Physics Learner,

I am Mr. Kotoka J.K, a student in the Department of Mathematics, Science and Technology Education in the University of South Africa (UNISA). I am interested in investigating the link between Physics teachers' technological and pedagogical content knowledge and their learners' performance in electricity.

The following questionnaire is aimed at obtaining information about your Physics teacher's teaching of Physics (electricity) in Grade 11. Your response will be anonymous, and the information gathered will help us improve the teaching of Physics and also help learners like you to perform better in Physics. I would appreciate your completion of the questionnaire. I hope that the 15 to 20 minutes it will take you will help us understand how to improve the teaching of Physics in South Africa.

Thank you in advance for your participation. If you have any question about the study or any of items in the questionnaire, you may inform your teacher and it will be addressed.

Yours sincerely,

Kotoka J.K.

Directions

1. This questionnaire requires you to rate your teacher's technological and pedagogical content knowledge in teaching Grade11 Physics.
2. For each statement mark ✓ or X in the appropriate box that corresponds to the extent of your agreement/disagreement.
3. Please give an answer/rating to every question/statement.

Section A. Demographic Information

Thank you for taking time to complete this questionnaire. Please answer each question to the best of your knowledge. Your thoughtfulness and candid responses will be greatly appreciated. Your individual name or identification number will not at any time be associated with your responses. Your responses will be kept completely confidential.

1. Learner Code/ Learner Number:.....
2. Name of School:
3. Age range (Years):
 13 – 15
 15 – 17
 17 – 19
 Over 17
4. Gender:
 Male,
 Female

Section B. Learner Confirmation Form

Technology is a broad concept that can mean a lot of different things. For the purpose of this questionnaire, technology is referring to digital technology/technologies. That is, the digital tools we use such as computers, laptops, iPods, handhelds, interactive whiteboards, software programs, etc. Please answer all of the questions.

		Strongly Disagree	Disagree	Slightly Disagree	Slightly Agree	Agree	Strongly Agree
1	My physics teacher keeps up with important new technologies.						
2	My physics teacher knows about a lot of different technologies.						
3	My physics teacher has sufficient knowledge of physics.						
4	My physics teacher is able to apply scientific ways of thinking during his/her teaching.						
5	My physics teacher develops lesson using our previous knowledge on the topic.						
6	My physics teacher assesses our performance after lessons.						
7	My physics teacher uses different teaching styles to accommodate different learners.						
8	My physics teacher gives different forms of assessment such as class work, homework, project and research work.						
9	My physics teacher uses wide range(variety) of teaching approaches such as lecturing, group discussion, practical's question and answers, to teach.						
10	My physics teacher's classroom is well organized and well managed.						
11	My physics teachers' teaching approaches are effective and that guides me in learning physics.						
12	My physics teacher chooses technologies that enhance my learning of physics						
13	My physics teacher chooses technologies that enhance his/her teaching approaches.						
14	My physics teacher uses technologies to teach which enhances better understanding of various concepts in physics.						
15	My physics teacher selects technologies which enhances what he/she teaches, how he/she teaches and what I learn.						
16	My physics teacher chooses technologies that bring out the main content of a lesson.						
17	My physics teacher teaches lessons that appropriately combine physics, technologies and teaching approaches.						

Appendix 3

Learner Electricity Learning Confirmatory Questionnaire (LELCQ)

The purpose of this questionnaire is to find out what the Grade 11 learners were taught by their teacher on electricity.

The topics are listed in column 1. In Column 2, indicate if the topic was taught by your teacher by ticking **Yes / No**.

No.	Column 1	Column 2	
		Yes	No
1	Define resistance - opposition to the flow of electric current	Yes	No
2	Unit of resistance; one ohm (Ω), one volt per ampere	Yes	No
3	Give a microscopic description of resistance - in terms of electrons moving through a conductor colliding with the particles of which the conductor (metal) is made and transferring kinetic energy.	Yes	No
4	Explain why a battery in a circuit goes flat eventually - refer to the energy transformations that take place in the battery and the resistors in a circuit	Yes	No
5	Current is constant through each resistor in series circuit.	Yes	No
6	Series circuits are called voltage dividers because the total potential difference is equal to the sum of the potential differences across all the individual components	Yes	No
7	Calculate the equivalent (total) resistance of resistors connected in series using: $R_s = R_1 + R_2 + \dots$	Yes	No
8	Voltage is constant across resistors connected in parallel	Yes	No
9	A parallel circuit is a current divider - the total current in the circuit is equal to the sum of the branch currents.	Yes	No
10	Calculate the equivalent (total) resistance of resistors connected in parallel using: $\frac{1}{R_p} = \frac{1}{R_1} + \frac{1}{R_2}$	Yes	No
11	Determine the relationship between current, voltage and resistance at constant temperature using a simple circuit	Yes	No
12	State the difference between Ohmic and non-Ohmic conductors, and give an example of each	Yes	No
13	Solve problems using the mathematical expression of Ohm's Law, $R=V/I$, for series and parallel circuits	Yes	No
14	Define power - the rate at which electrical energy is converted in an electric circuit and is measured in watts (W)	Yes	No
15	Electrical power dissipated in a device is equal to the product of the potential difference across the device and current flowing through it i.e. $P=IV$	Yes	No
16	Power can also be given by $P=I^2R$ or $P=V^2/R$	Yes	No
17	Electrical energy is given by $E=Pt$ and is measured in joules (J)	Yes	No
18	The kilowatt hour (kWh) refers to use of 1 kilowatt of electricity for 1 hour	Yes	No
19	Solve/calculate problems involving: Circuits, including the concept of power	Yes	No
20	Solve/calculate problems involving: Circuits, including the concept of electrical energy	Yes	No
21	The cost of electricity usage, given the power specifications of appliances used and the duration if the cost of 1 kWh is given	Yes	No

Appendix 4
LEARNER ELECTRICITY ACHIEVEMENT TEST (LEAT)

Total: 60 Marks

Time: 1 Hour 30 Minutes

Instructions and information

- 1. This question paper consists of FOUR questions. Answer ALL questions**
- 2. Number the questions correctly according to the numbering system used in this question paper.**
- 3. An approved calculator (non-programmable and non-graphical) may be used**
- 4. All calculations must be clearly shown.**
- 5. Write neatly and legibly.**

This question paper consists of 6 Pages

QUESTION 1

Give ONE word/term for each of the following descriptions. Write only the word/term next to the question number (1.1–1.5) in the ANSWER BOOK.

- 1.1 Arrangement of resistors in parallel.
- 1.2 Series connection of resistors in an electric circuit.
- 1.3 An area where a charged object experiences a force.
- 1.4 Unit in which induced emf is measured.
- 1.5 The rate of flow of charge.

[2x5=10]

QUESTION 2

Four options are provided as possible answers to the following questions. Each question has only ONE correct answer. Write only the letter (A–D) next to the question number (2.1–2.5) in the ANSWER BOOK.

- 2.1 The strength of an electric field is:
 - A. directly proportional to the force exerted on a point charge, and inversely proportional to its charge.
 - B. directly proportional to the force exerted on a point charge, and directly proportional to its charge.
 - C. inversely proportional to the force exerted on a point charge, and directly proportional to its charge.
 - D. inversely proportional to the force exerted on a point charge, and inversely proportional to its charge.

2.2 Two resistors of $7\ \Omega$ and $3\ \Omega$ respectively are connected in parallel. The cell in the circuit has an emf of $4,2\ \text{V}$. The current flowing through the $3\ \Omega$ resistor (in A) is:

- A. 2,1
- B. 0,6
- C. 2
- D. 1,4

2.3 Compare circuits M and N below. Identical batteries with negligible internal resistance are used. The light bulbs are identical. How will the brightness of the bulbs in the two circuits compare?

M

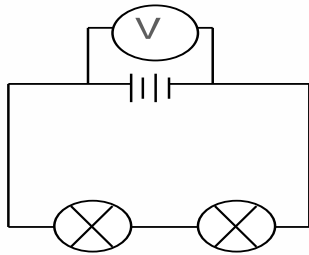

N

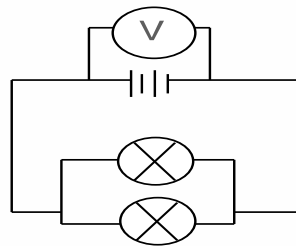

- A. The light bulbs in M and N are equally bright, since they are identical.
- B. The light bulbs in M and N are equally bright, since the batteries are identical.
- C. The light bulbs in M are brighter.
- D. The light bulbs in N are brighter.

2.4 In the circuit diagram below, the internal resistance of the battery and the resistance of the conducting wires are negligible. The emf of the battery is E

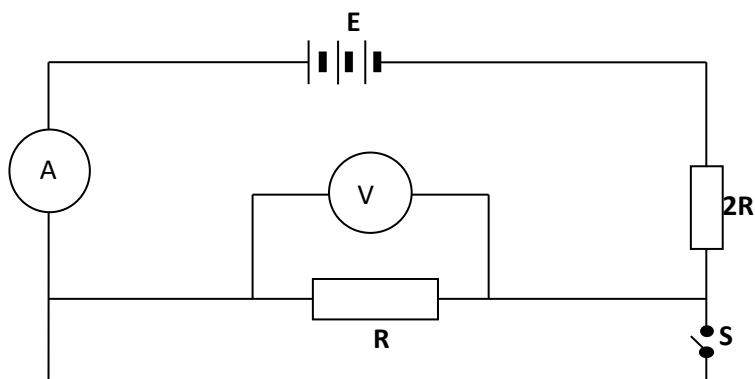

When switch **S** is closed, the reading on the voltmeter **V**, in volts, is ...

- A. 0
- B. $\frac{1}{3} E$
- C. $\frac{2}{3} E$
- D. E

2.5 In the circuit diagram below the resistors R_1 , R_2 and R_3 are identical. The battery has no internal resistance.

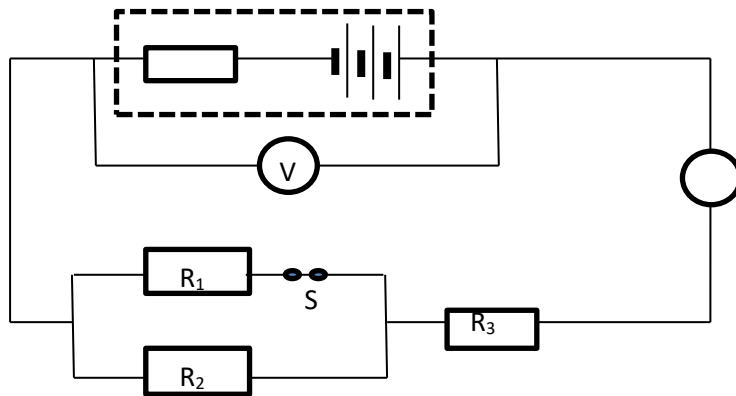

How will the readings on the ammeter and the voltmeter change when switch S is opened?

	Ammeter	Voltmeter
A	Increase	Increase
B	Increase	Decrease
C	Decrease	Increase
D	Decrease	Decrease

2.6 Which ONE of the circuits below can be used to measure the current in a conductor X and the potential difference across its ends?

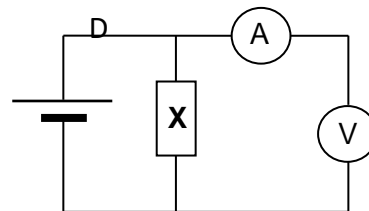
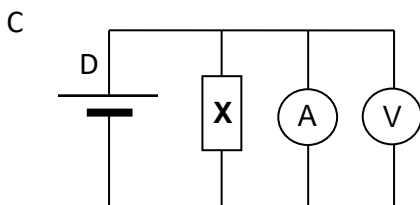
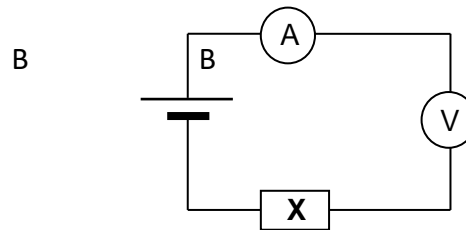
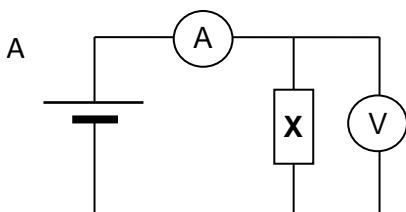

[1x2=12]

QUESTION 3

Electricity is sold at 61 c per kWh. The geyser rated 2500W is switched on for 12 hours.

- 3.1 Calculate the cost of the electric energy that the geyser used in that time. (5)
3.2 Mention FIVE ways you can save on electricity cost at home. (5)

QUESTION 4

- 4.1 The circuit represented below is used to investigate the relationship between the current passing through and the potential difference across resistor P.

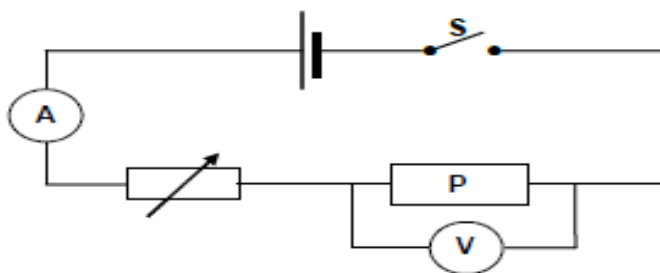

The results obtained are used to draw the graph below.

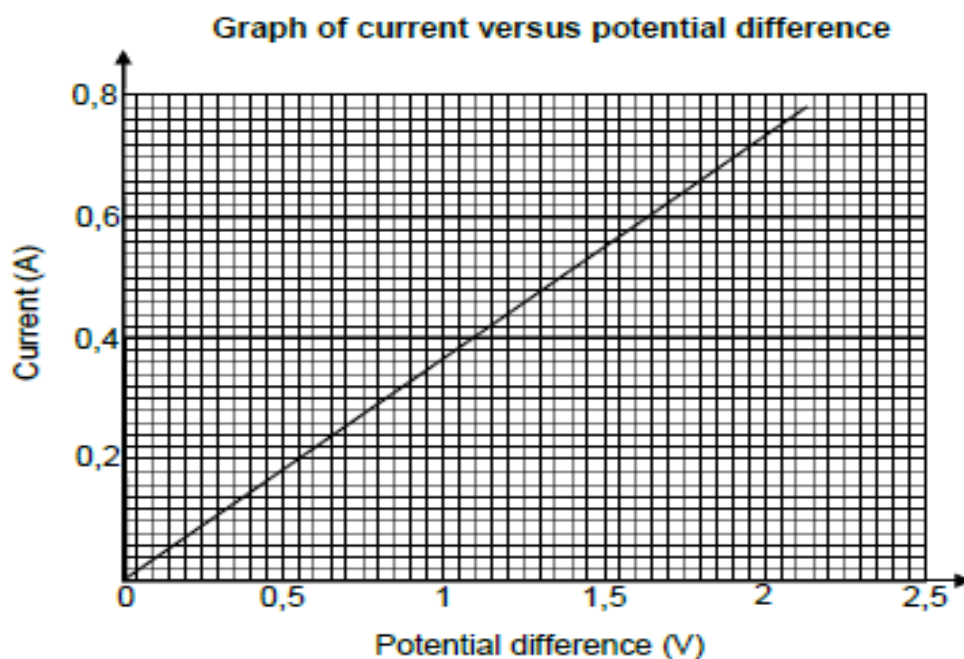

- 4.1.1 Write down the independent variable. (2)
4.1.2 Write down the variable that must be controlled. (2)
4.1.3 Write down the conclusion that can be obtained from the graph. (2)
4.1.4 Using the gradient of the graph, calculate the resistance of resistor P. (6)

4.2 A battery with an emf of 20 V is connected to a circuit as shown.

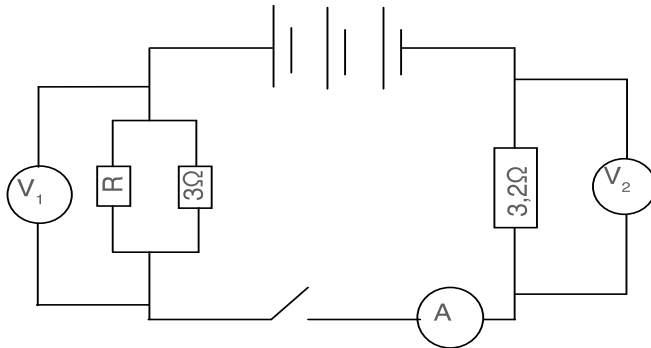

When the switch is closed, the ammeter reading is 4 A.

- 4.2.1 Calculate the effective resistance of the circuit. **(3)**
- 4.2.2 Calculate the reading on V_1 when the switch is closed. **(6)**
- 4.2.3 Calculate the resistance of resistor R . **(7)**
- [28]**

(LEAT) INSTRUMENT MEMO

QUESTION 1 (10 Marks)

- 1.1 current divider ✓✓
- 1.2 Potential divider or voltage dividers ✓✓
- 1.3 Electric field ✓✓
- 1.4 Volt ✓✓
- 1.5 Current ✓✓

QUESTION 2 (12 Marks)

- 2.1 A ✓✓
- 2.2 D ✓✓
- 2.3 D ✓✓
- 2.4 B ✓✓
- 2.5 C ✓✓
- 2.6 A ✓✓

QUESTION 3 (10 Marks)

- 3.1 Cost of energy used = kW × h × cost ✓
= 2,5 × 12 × 61 ✓✓
= 1 830 c ✓
= R18,30 ✓

Option 2:

$$\begin{aligned} \text{Energy} &= P \times \Delta t \quad \checkmark \\ &= 2.5 \times 12 \quad \checkmark \\ &= 30\text{kWh} \quad \checkmark \\ \text{Cost} &= \text{kWh} \times \text{tariff} \\ &= 30 \times 0.6 \quad \checkmark \\ &= \text{R}18.30 \quad \checkmark \end{aligned}$$

- 3.2 Ways you can save on electricity cost (ANY FIVE X 5)
- Switch off geysers during the day.
 - Switch off all devices at the wall sockets.
 - Boil only enough water.
 - Close doors and windows when a heater is turned on.
 - Lower the temperature of the hot water device.
 - Switch off lights when you leave a room
 - Use the right size pot on a stove plate.
 - Do not turn stove plates up to high.
 - Use compact fluorescent lamps.

- Switch off your computer screen during the night.
- Use natural ventilation.
- Iron clothes in bulk.
- Use energy saving bulbs.
- Do not leave fridge door open for too long

QUESTION 4 (28 Marks)

4.1.1 Potential difference or Voltage ✓✓

4.1.2 Temperature ✓✓
Resistance

4.1.3 Current is directly proportional to potential difference / It obeys Ohm's law /
Potential difference increases current increases. ✓✓

4.1.4 Gradient/m = $\frac{0.18-0}{0.5-0} = 0.36$ ✓✓✓

$$R = \frac{1}{0.36} = 2.78\Omega \text{ ✓✓✓}$$

Option 2

$$R = \frac{\Delta V}{\Delta I} = \frac{2-0.5}{0.72-0.2} \text{ ✓✓} = \frac{1.5}{0.52} \text{ ✓✓} = 2.8 \text{ ✓✓}$$

4.2.1 $R = \frac{V}{I} \text{ ✓}$

$$= \frac{20}{4} \text{ ✓}$$

$$= 5 \Omega \text{ ✓}$$

4.2.2 $V_2 = (I_{\text{TOTAL}})R_{3.2} \text{ ✓}$

$$V_2 = 4 \times (3.2) \text{ ✓}$$

$$V_2 = 12.8 \text{ V } \text{ ✓}$$

But emf = $V_{\text{TOTAL}} = V_1 + V_2 \text{ ✓}$

$$20 = V_1 + 12.8 \text{ ✓}$$

$$V_1 = 7.2 \text{ V } \text{ ✓}$$

$$4.2.3 \quad V_1 = 7.2V + V_{\text{parallel}} = V_{3\Omega} \checkmark$$

$$R_{\text{parallel}} = \frac{V}{I} = \frac{7.2}{4} \checkmark \checkmark$$

$$R = 1.8 \Omega \checkmark$$

$$\frac{1}{R_p} = \frac{1}{R} + \frac{1}{R_3} \checkmark$$

$$\frac{1}{1.8} = \frac{1}{R} + \frac{1}{3} \checkmark$$

$$R = 4.5 \Omega \checkmark$$

Option 2

$$R_T = R_S + R_P \checkmark$$

$$5 = 3.2 + R_P$$

$$5 - 3.2 = R_P \checkmark$$

$$R_P = 1.8 \Omega \checkmark$$

$$R_P = \frac{R_1 \times R_2}{R_1 + R_2} \checkmark$$

$$1.8 = \frac{3 \times R_2}{3 + R_2} \checkmark$$

$$1.8(R + 3) = 3R$$

$$5.4 + 1.8R = 3R \checkmark$$

$$5.4 = 3R - 1.8R$$

$$5.4 = 1.2R$$

$$R = 4.5 \Omega \checkmark$$

Option 3

$$V_3 = I_3 R_3 \checkmark$$

$$I_3 = \frac{7.2}{3}$$

$$I_3 = 2.4\text{A} \checkmark$$

$$I_T = I_R + I_3 \checkmark$$

$$4 = I_R + 2.4$$

$$I_R = 1.6\text{A} \checkmark$$

$$V_R = I_R R_R \checkmark$$

$$R_R = \frac{7.2}{1.6} \checkmark$$

$$R_R = 4.5 \Omega \checkmark$$

TOTAL MARKS = [60]

Appendix 5

Cognitive level complexity of the LEAT according the CAPS document.

Questions		Cognitive Level	Annotation
1.1	Arrangement of resistors in parallel.	1	CAPS require the Knowledge of arrangement of resistors in series and parallel and the questions demand recall from memory.
1.2	Series connection of resistors in an electric circuit.	1	
1.3	An area where a charged object experiences a force.	1	The question demands recall from memory
1.4	Unit in which induced emf is measured.	1	The question demands recall from memory
1.5	The rate of flow of charge.	1	The question demands Recall from memory
2.1	The strength of an electric field is:	1	The question demands recall from memory
2.2	Two resistors of $7\ \Omega$ and $3\ \Omega$ respectively are connected in parallel. The cell in the circuit has an emf of $4,2\ \text{V}$. Calculate the current flowing through the $3\ \Omega$ resistor.	3	The question demands the learners' deeper understanding and the ability to calculate current in electric circuits.
2.3	Comparing circuits M (bulbs in series) and N (bulbs in parallel). Identical batteries with negligible internal resistance are used. The light bulbs are identical. How will the brightness of the bulbs in the two circuits compare?	2	These questions demand learners grasping the meaning of information in electric circuits by interpreting and comparing what has been learned with respect to bulbs, cells resistors, and voltmeter and ammeter readings.
2.4	In the circuit diagram, the internal resistance of the battery and the resistance of the conducting wires are negligible. The emf of the battery is E . When switch S is closed, the reading on the voltmeter V , in volts, is	2	
2.5	In the circuit diagram, the resistors R_1 , R_2 and R_3 are identical. How will the readings on the ammeter and the voltmeter change when switch S is opened?	2	
2.6	Which ONE of the circuits can be used to measure the current in a conductor X and the potential difference across its ends?	3	The question demands learners' ability to apply knowledge and skills in other to classify the different circuits and choose the correct one.
3.1	Electricity is sold at $61\ \text{c}$ per kWh. Calculate the cost of the electric energy that a geyser used in 12 hours.	3	The question demands the learners' ability to calculate cost of household electricity usage.

3.2	Mention FIVE ways you can save on electricity cost at home.	2	The question demands the learners' ability to recall ways to use electricity wisely and save on its cost at home
4.1.1	Write down the independent variable from the graph of current versus potential difference.		
4.1.2	Write down the variable that must be controlled of the graph in 4.1.1.		
4.1.3	Write down the conclusion that can be obtained from the graph in 4.1.1.	3	These questions demand the learners' ability to apply knowledge and skills in order to analyse the complex circuit and identify the parallel and series arrangements of the resistors, voltmeters and the ammeter.
4.1.4	Using the gradient of the graph, calculate the resistance of resistor P.	3	
4.2.1	Calculate the effective resistance of the circuit.	3	
4.2.2	Calculate the reading on V_1 when the switch is closed.	3	
4.2.3	Calculate the resistance of resistor R.	4	
			The question demands the learner works at an extended abstract level. The learner makes decisions based on in-depth Reflection and assessment based on the previous sub-questions.

Appendix 6

Grade 12 Pilot Sample

Grade 12 Pilot Sample					
	TEST 1	TEST 2		TEST 1	TEST 2
Learner	Score	Score	Learner	Score	Score
1	16	26	28	33	43
2	13	24	29	13	11
3	26	27	30	21	22
4	17	25	31	18	24
5	21	21	32	21	16
6	21	23	33	23	22
7	14	10	34	28	22
8	15	16	35	15	22
9	15	30	36	24	20
10	15	15	37	21	17
11	28	30	38	18	15
12	16	22	39	17	15
13	20	11	40	25	24
14	18	20	41	32	29
15	23	28	42	16	27
16	18	13	43	21	21
17	15	13	44	16	19
18	19	38	45	7	13
19	14	16	46	15	20
20	26	28	47	20	13
21	15	24	48	18	19
22	18	11	49	21	20
23	9	14	50	9	16
24	20	22	51	14	12
25	23	32	52	24	29
26	16	16	53	25	28
27	13	18			

Appendix 7

SPSS results of the calculation of the Spearman correlation coefficient.

Case Processing Summary

		N	%
Cases	Valid	53	100.0
	Excluded ^a	0	.0
	Total	53	100.0

a. Listwise deletion based on all variables in the procedure.

Reliability Statistics

Cronbach's Alpha	N of Items
.730	2

Appendix 8

SPSS results of the calculation of the reliability of the PTPCKQ, LCPTTPCKQ and LELCQ

Case Processing Summary

		N	%
Cases	Valid	34	81.0
	Excluded ^a	8	19.0
	Total	42	100.0

a. Listwise deletion based on all variables in the procedure.

Reliability Statistics

Cronbach's Alpha	N of Items
.932	27

Case Processing Summary

		N	%
Cases	Valid	41	97.6
	Excluded ^a	1	2.4
	Total	42	100.0

a. Listwise deletion based on all variables in the procedure.

Reliability Statistics

Cronbach's Alpha	N of Items
.889	17

Appendix 9

University of South Africa ethical clearance



Jonas Kwadzo Kotoka (45133352)
College of Science, Engineering and Technology
UNISA
Johannesburg

2014-04-22

Permission to conduct research project

Ref: 001/JKK/2014

The request for ethical approval for your PhD (MST) Physics Education research project entitled "Investigating physics teachers' technological and pedagogical content knowledge: The case of teaching electricity" refers.

The College of Science, Engineering and Technology's (CSET) Research and Ethics Committee (CREC) has considered the relevant parts of the studies relating to the abovementioned research project and research methodology and is pleased to inform you that ethical clearance is granted for your study as set out in your proposal and application for ethical clearance.

Therefore, involved parties may also consider ethics approval as granted. However, the permission granted must not be misconstrued as constituting an instruction from the CSET Executive or the CSET CREC that sampled interviewees (if applicable) are compelled to take part in the research project. All interviewees retain their individual right to decide whether to participate or not.

We trust that the research will be undertaken in a manner that is respectful of the rights and integrity of those who volunteer to participate, as stipulated in the UNISA Research Ethics policy. The policy can be found at the following URL:

http://on.unisa.ac.za/content/departmental_policies/docs/ResearchEthicsPolicy_appoCounc_21Sept07.pdf

Please note that if you subsequently do a follow-up study that requires the use of a different research instrument, you will have to submit an addendum to this application, explaining the purpose of the follow-up study and attach the new instrument along with a comprehensive information document and consent form.

Yours sincerely

A handwritten signature in black ink, appearing to be 'Jonas Kwadzo Kotoka', written over a light blue horizontal line.

Chair: College of Science, Engineering and Technology Ethics Sub-Committee

University of South Africa
College of Science, Engineering and Technology
The Science Campus
P.O. Christian de Wet Road and Pioneer Avenue,
Florida Park, Roodpoort
Private Bag 36, Florida, 1710
www.unisa.ac.za/cset



Appendix 10
Mpumalanga Department of Education ethical clearance

**APPROVAL TO CONDUCT RESEARCH FOR MR. K.J. KWADZO
PHYSICAL SCIENCE EDUCATION: PhD DEGREE**



education
DEPARTMENT: EDUCATION
MPUMALANGA PROVINCE

Private Bag X 11341
Nelspruit 1200
Government Boulevard
Riverside Park
Building 5
Mpumalanga Province
Republic of South Africa

IZifundo ezintsha Umyango weFundo Department of Education Umyango wezifundo
E-mail: A.A. Baiy/013 766 5478

Mr. K.J. Kwadzo
Institute for Science and Technology Education
Theo Van Wijk Building 6-44
Pretoria
0700

RE: APPLICATION TO CONDUCT RESEARCH: MR. K.J. KWADZO

Your application to conduct research was received on the on the 03 March 2014. The title of your study is: "The link between Physics teachers' technological and pedagogical content knowledge and their learner's performance in electricity in grade 11 physics." The aims, objectives, the questions and the overall design of your study give an impression that the outcomes of the study will improve the teaching and learning of Physical Science in the FET level. Your request is approved subject to you observing the content of the departmental research manual which is attached. You are required to discuss with the principals of the sampled schools regarding the approach to your observation and data collection as no disruption of tuition will be allowed. You are also requested to adhere to your University's research ethics as spell out in your research ethics document.

In terms of the attached manual (2.2. bullet number 4 & 6) data or any research activity can only be conducted after school hours as per appointment. You are also requested to share your findings with the relevant sections of the department so that we may consider implementing your findings if that will be in the best interest of department.

For more information kindly liaise with the department's research unit @ 013 766 5478 or a.baiy@education.mpu.gov.za. The department wishes you well in this important project and pledges to give you the necessary support you may need.

Sisonke Sifundise Sive



MPUMALANGA
A Renewing Spirit

Wm

APPROVAL TO CONDUCT RESEARCH FOR MR. K.J. KWADZO
PHYSICAL SCIENCE EDUCATION: PhD DEGREE

APPROVED/NOT APPROVED:

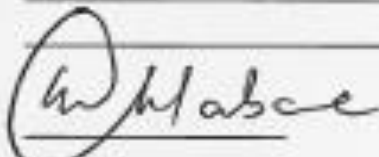

MRS N. C. MHLABANE
HEAD OF DEPARTMENT

27 3, 14
DATE

Appendix 11

Letter to the Principal

Dear Principal,

I am Jonas Kwadzo Kotoka, a full time teacher at Hoërskool Staatspresident C. R. Swart, and a PhD student at the University of South Africa (UNISA). As a requirement for the award of a Doctor of Science degree in Science, Mathematics and Technology Education, I am investigating the link between Physics teachers' technological and pedagogical content knowledge and their learners' performance in electricity in grade 11 Physics.

I would like to humbly request your permission to invite your school to participate in an academic research study in this regard. In this study the grade 11 Physical science learners will be expected to write one test and also respond to two questionnaires after they have been taught electricity by their teacher(s). The teacher(s) will also be expected to respond to one questionnaire.

There would be no interruption of your normal school programme, the normal school timetable and the Physical Science periods will be used. The data collected will be treated with confidentiality and the names of your school, the teachers and the learners will not be used in the analysis of the data.

This study is being conducted with the view to offering useful solutions to the teaching of physics in order to improve learners' performance in the subject.

Please do not hesitate to contact me if you have any further queries or clarifications. My contact details are as follows:

Cell number: 0734639661.

Email: kotoka2002@yahoo.com and kotokajk@gmail.com

I look forward to your anticipated positive response.

Thank you.

Yours faithfully,

()

Kotoka, Jonas Kwadzo.

Consent form for principal

I _____ the principal of

_____ School, hereby grants consent to Mr Kotoka

Jonas Kwadzo, to involve the Grade 11 learners and teacher(s) in his research. The data

collected should be treated with confidentiality and the name of the school and the

participants (teachers and learners) should not be mentioned in the analysis of the data. The

participants (teachers and learners) may withdraw from the study at any time.

Signature: _____ Date: _____

Consent form for teachers to participate

I _____ a teacher at

_____ School hereby grants consent to Mr. Kotoka Jonas Kwadzo to be part of his research. The data that will be collected from me and my class should only be used for research purposes. The data collected should be treated with confidentiality and the name of the participants (teachers and learners) should not be mentioned in the analysis of the data. The participants (teachers and learners) may withdraw from the study at any time.

Signature: _____ Date: _____

Appendix 13

Letter to the parent

Dear parent,

I am Jonas Kwadzo Kotoka, a full time teacher at Hoërskool Staatspresident C. R. Swart, and a PhD student at the University of South Africa (UNISA). As a requirement for the award of a Doctor of Science degree in Science, Mathematics and Technology Education, I am investigating the link between Physics teachers' technological and pedagogical content knowledge and their learners' performance in electricity in grade 11 Physics.

I will like to seek your consent for your child to be part of an academic research study in this regard. I will collect data by administering a test on electricity and two questionnaires.

Participation in this research is voluntary and there will be no negative consequences whatsoever for refusal to participate.

There will be no interruption of your child's normal school programme, the normal school timetable shall be followed and your child will be taught by their usual school teacher. The data collected will be treated with confidentiality and the name of your child will not be mentioned in the analysis of the data. That is, the name and identity of your child will be protected in this study.

This study is being conducted with the view to offering useful solutions to the teaching of physics in order to improve learners' performance in the subject.

Please do not hesitate to contact me if you have any further queries or clarifications. My contact details are as follows:

Cell number: 0734639661.

Email: kotoka2002@yahoo.com

I look forward to your anticipated positive response.

Thank you.

Yours faithfully,

()

Kotoka, Jonas Kwadzo.

Consent form for parents

I _____ the parent of _____ hereby grant consent to Kotoka Jonas Kwadzo to allow my ward to be part of his research. The data that will be collected from my ward and his/her class should only be used for research purposes. The data collected should be treated with confidentiality and neither the name of the school, my ward or the teacher should be mentioned in the analysis of the data. The participants (teachers and learners) may withdraw from the study at any time.

Parents Signature: _____ Date: _____

Ward's name _____ Ward's Signature: _____ Date: _____

Appendix 14

Consent form for learner participants in the study

I,, of(school) have read and understood the procedures involved in the study and what is expected of me as a participant. I understand that my name and identity will be protected in the study. I willingly give consent that I am willing to participate in the study. The data collected shall be treated with confidentiality and the name of the participants (teachers and learners) will not be mentioned in the analysis of the data. The participants (teachers and learners) may withdraw from the study at any time.

Thank you.

Signature of learner

Date

Name (Please print)

Appendix 15

PHYSICAL SCIENCES LESSON-PLAN GRADE:11

Knowledge Area: Electric Circuits		Electric Circuits	
Time-Duration : 4-hours		Concepts: Potential difference, Current and Resistance	
Resources:			
Dates		Date: 11-12-08 - 2014	Date: 13-08-2014
Lessons:		Lesson:1.1	Lesson:1.2
Duration		2-hours	1-hour
Concepts		Rel.between: Current,Potential difference and Resistance at constant temperature	State the difference between Ohmic and non-Ohmic conductor and give examples of each
Prior Knowledge [Baseline Assessment]		<ul style="list-style-type: none"> ●What is current? Give its units ●What is potential difference? Give units ●What is electrical Resistance? Give units 	<ul style="list-style-type: none"> ●What is an Ohmic conductor? Name two examples ●What is a non-ohmic conductor? Name two examples
Core Knowledge/ Main body Teacher-Activities		<ul style="list-style-type: none"> ●Define current strength as the amount of charge moving through a certain point in a circuit in one second $I=Q/\Delta t$ ●Potential difference is work done in moving a charge from one point to the other in an electric field ●Electrical resistance is the opposition a conductor offers to a flow of charge ●The magnitude of the current flowing in a circuit is dependent on the nature of the conductor 	<ul style="list-style-type: none"> ●Explain that Ohmic conductor obeys Ohm's Law. $V \propto I$ provided temperature remains constant ●Ratio $V/I=R$ remains constant ●Gradient of the graph=value of the resistance of resistor ●Graph of V vs I yield a straight line through the origin e.g Nichrome wire ●Non-ohmic conductor does not obey Ohm's Law ●Resistance changes. $R \propto T$ ●No straight line graph e.g Light bulb/Electrolyte
Learner-Activities What?[Tasks]		Hmework/Classwork/experiments/Class test	Homework/Classwork/Experiment

How [Tool]	Memo	Memo	Memo
Time	Start: End:	Start: End:	Start: End:

Educator: _____ Signature:..... Date:.....

HOD : Masombuka A.B Signature:..... Date:.....

Principal Ngwenya M.L Signature:..... Date:.....

Appendix 15 cont.

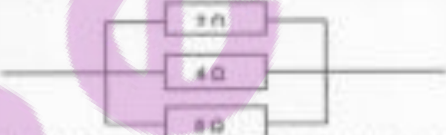
GRADE	11	SUBJECT	Physical Sciences	WEEK	26	TOPIC	Electric Circuit Calculations: Time: 45 minutes	LESSON	4
LESSON SUMMARY FOR: DATE		STARTED:		DATE		COMPLETED:			
LESSON OBJECTIVES		<p>The following results will be the outcomes of this lesson. The learners must be able to:</p> <ul style="list-style-type: none"> Calculate using the mathematical expression of Ohm's Law, $R = \frac{V}{I}$ Determine the equivalent resistance of resistors in series and parallel. Determine current, potential difference and resistance for circuits containing arrangements of resistors in series and in parallel. 							
TEACHER ACTIVITIES		LEARNER ACTIVITIES	TIMING	RESOURCES NEEDED					
<p>1. Teaching Methods: Explanation, Observation, Demonstration, Question and answer.</p> <p>2. Lesson Development</p> <p>2.1 <u>Introduction:</u></p> <p>2.1.1 Pre-knowledge required for the lesson:</p> <p>2.1.1.1 Knowledge of using formulas and substituting into a formula.</p> <p>2.1.1.2 Knowledge of using a calculator.</p> <p>2.2 <u>Main Body (Lesson presentation):</u></p> <p>a) Start the lesson by asking the learners about the connection of light bulbs in the house.</p> <p>b) Explain the series and parallel combinations. Provide the formulas to the learners:</p> <p>c) Compare the total resistance of the resistors in series and in parallel in a circuit. Learners should try the following examples.</p> <p>1. Resistors in series: The total resistance of the resistors in series is $R_t = R_1 + R_2 + R_3$</p> <p>Example: Calculate the total resistance for the following resistor:</p>  <p>2. Resistors in parallel: The total resistance of resistors in parallel is $\frac{1}{R_p} = \frac{1}{R_1} + \frac{1}{R_2} + \frac{1}{R_3}$</p> <p>Example: Consider the following combinations for resistors</p>  <p>Calculate the equivalent resistance of the parallel resistors.</p> <p>The educator must explain how to calculate the equivalent/total</p>		<p>Work in groups.</p> <p>Answer the questions from (a) up to (c), and interact with the teacher when answering the questions.</p> <p>Homework: Circuit Calculations from the grade 11 Physical Sciences Textbook (Excluding Internal Resistance)</p>	<p>Morning Homework: 5 min</p> <p>Answering the questions from (a) up to (c): 50 min</p> <p>Conclusion: 5 min</p> <p>Homework: 30 min</p>	<ul style="list-style-type: none"> Chalk and Chalkboard Physical Science-Grade 11 study guide/text book Calculator 					

Appendix 15 cont.

resistance of the resistors connected in the combination of series and parallel.

The learners can try the following example:

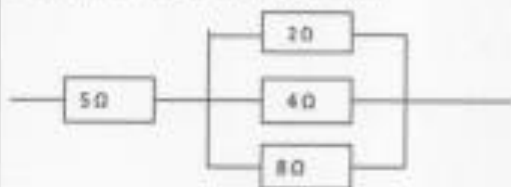

Calculate the total resistance for the above combination of connection.

• Explain the important aspects in circuit calculations by using the following examples. Learners should try it first.

• In a series connection of resistors the potential difference splits and the current remains the same.

Eg.

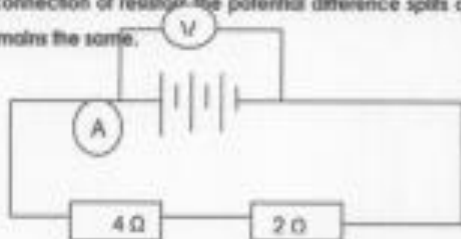

If V across the battery is 12 V. Calculate:

- (i) The total resistance for the circuit.
- (ii) The ammeter reading.
- (iii) the potential difference across the 4Ω and 2Ω resistors.

• In the parallel connection of resistors the potential difference remains the same and the current splits.

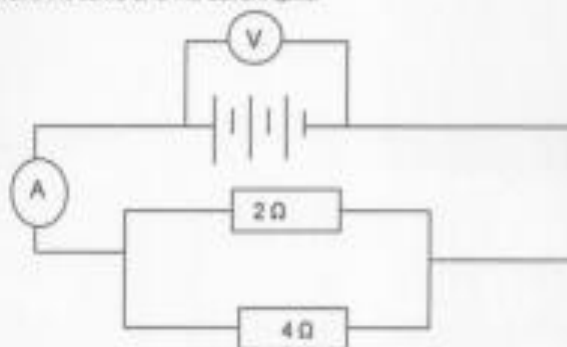

If V across the battery is 12 V. Calculate:

- (i) The total resistance for the circuit.
- (ii) the ammeter reading.
- (iii) the potential difference across the 4Ω and 2Ω resistors.
- (iv) The current across the 2Ω resistor

Appendix 15 cont.

(v) The current across the 4 Ω resistor.

Do an example with the combination of parallel and series connection.

Example:

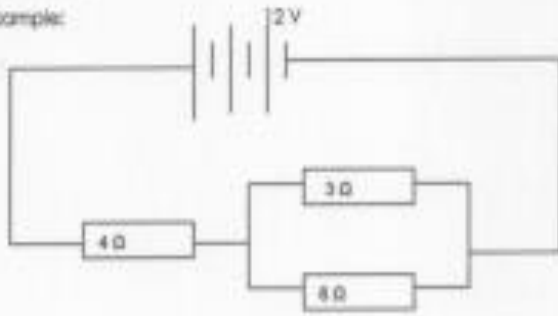

(i) Calculate the total resistance of the circuit.
 (ii) Calculate the total current of the circuit.
 (iii) Calculate the potential difference across the 4 Ω resistor.
 (iv) Calculate the potential difference across the 6 Ω and 3 Ω resistor.
 (v) Calculate the current in the 3 Ω resistor.
 (vi) Calculate the current in the 6 Ω resistor.

3. Conclusion:

- Explain the relationship between V, I and R

$$R \propto V \text{ and } R \propto \frac{1}{I}$$

- Learners must be given more examples.

Reflection/Notes:

Name of Teacher:		HOD:	
Sign:		Sign:	
Date:		Date:	

Appendix 16

	CURRICULUM AND ASSESSMENT POLICY STATEMENT						
LESSON PREPARATION							
GRADE	11	SUBJECT	Physical Sciences	WEEK	27 Lesson 1-4	TOPIC	Electrical Energy and Power
LESSON SUMMARY FOR:			DATE STARTED:	DATE COMPLETED:		TIME: 240 minutes	
LESSON OBJECTIVES	<p>At the end of the lesson learners should be able to:</p> <ul style="list-style-type: none"> • Define power • Use the formula $P = VI$ or $P = V^2/R$ or $P = I^2 R$ • Solve the problems involving circuit • Use the formula $E = PT$ and is measured in Joules (J) • Solve problems involving the concept of electrical energy • Know that kWh refers to 1 kilowatt of electricity for 1 hour • Calculate the cost of electricity usage 						
TEACHING and LEARNING ACTIVITIES							
<p>1. TEACHING METHOD/S USED IN THIS LESSON: Question and Answer</p> <p>2. LESSON DEVELOPMENT</p> <p>2.1 Introduction</p> <p>i) PRE-KNOWLEDGE learners need understanding of the following:</p> <p>(a) Solve problem using the formula $R = V/I$</p> <p>(b) Solve the problems involving circuit diagram</p> <p>ii) BASELINE ASSESSMENT (educator to design a worksheet/ transparency or write questions on the board [preferably a worksheet to save time] to gauge the learners memory of their relevant prior knowledge)</p> <p style="text-align: center;"><i>QUESTIONS for the BASELINE ASSESSMENT [5 min]</i></p>							

Appendix 16 cont.



CURRICULUM AND ASSESMENT POLICY STATEMENT LESSON PREPARATION

a)

2.2 Main Body (Lesson presentation) [30 min]

Resistance, Ohm's law

- Determine the relationship between current, voltage and resistance at constant temperature using a simple circuit.
- State the difference between Ohmic and non-Ohmic conductors, and give an example of each.
- Solve problems using the mathematical expression of Ohm's Law

V

$R = I$ for series and parallel circuits.

Maximum four resistors

Power,

- Define power as the rate at which electrical energy is converted in an electric circuit and is measured in watts (W).
- Know that electrical power dissipated in a device is equal to the product of the potential difference across the device and current flowing through it i.e. $P=IV$.
- Know that power can also be given by $P = I^2R$ or $P = V^2/R$.
- Solve circuit problems involving the concept of power.
- Know that the electrical energy is given by $E = Pt$ and is measured in joules (J).
- Solve problems involving the concept of electrical energy (E).

Know that the kilowatt hour (kWh) refers to the use of 1 kilowatt of electricity for 1 hour.

- Calculate the cost of electricity usage given the power specifications of the appliances used as well as the duration if the cost of 1 kWh is given.

Get learners to estimate the cost saving by consuming less electricity by switching off devices.

Note:

Textbooks use both kWh AND kWhr as abbreviations for kilowatt hour.

2.2 Learners Activities [15 min]

[Educators need to add more questions such as one word and multiple choice questions which could not be included because of space]



CURRICULUM AND ASSESMENT POLICY STATEMENT LESSON PREPARATION

2.2.1

3. Conclusion

Activity to Re-enforce lesson (Educator may summarise the main aspects of the lesson) [5 min.]

HOMEWORK QUESTIONS/ ACTIVITY (educator must give learners a few questions to answer at home by either writing them on the chalkboard or giving an exercise from the prescribed textbook) [30 min]

RESOURCES USED:

Name of Teacher _____

SIGN: _____

Date: _____

Name of HOD: _____

SIGN: _____

Date: _____

Appendix 17

lesson plans 

Term 3

Lesson plan 12
PHYSICAL SCIENCES
Physics Grade 11

KNOWLEDGE AREA	ELECTRICITY AND MAGNETISM	TOTAL TIME: 24 Days
Term	3	
Unit 3	ELECTRICAL CIRCUITS Current Potential difference Resistance Energy conversion in circuit Power Cost calculation Saving electricity	
Date	/ /20__	
Resources	Doc Scientia Physical Sciences Book 1 Grade 11 P. 256 – 304	
Time	14 days	
Core knowledge	Resistance, Ohm's law <ul style="list-style-type: none"> • Determine the relationship between current, voltage and resistance at constant temperature using a simple circuit. • State the difference between Ohmic and non- Ohmic conductors, and give an example of each. • Solve problems using the mathematical expression of Ohm's Law $R = \frac{V}{I} \text{ for series and parallel circuits.}$ Maximum four resistors Power, energy <ul style="list-style-type: none"> • Define power as the rate at which electrical energy is converted in an electric circuit and is measured in watts (W). • Know that electrical power dissipated in a device is equal to the product of the potential difference across the device and current flowing through it i.e. $P=IV$. • Know that power can also be given by $P = I^2R$ or $P = V^2/R$. • Solve circuit problems involving the concept of power. • Know that the electrical energy is given by $E = Pt$ and is measured in joules (J). • Solve problems involving the concept of electrical energy (E). 	

Appendix 17 cont.



Core knowledge	<ul style="list-style-type: none"> • Know that the kilowatt hour (kWh) refers to the use of 1 kilowatt of electricity for 1 hour. • Calculate the cost of electricity usage given the power specifications of the appliances used as well as the duration if the cost of 1 kWh is given. <p>Get learners to estimate the cost saving by consuming less electricity by switching off devices.</p> <p>Note: Textbooks use both kWh and kWhr as abbreviations for kilowatt hour.</p>		
Practical activity/ experiments	Experiment 16 P. 260 – 262 Experiment 17 P. 262 – 263 Practical demonstration 3 P. 271 – 273		
Assessment method	Class test	Control test	Project
	Experiment	Class work	Building models, posters or interviews
Resources	Workbook, transparencies Summary P. 282 – 284 Mind maps P. 299 – 304		
Homework	Exercise 19 P. 267 Exercise 20 BI 274 – 276 Exercise 21 P. 280 – 282 Question paper P. 286 – 298		

Appendix 18

Editing Press

Editorial Certificate

This certificate is to affirm that Editing Press Inc., comprising faculty and postgraduates from the Universities of Oxford and Cambridge, has edited, to the best of its members' abilities, the work entitled

INVESTIGATING PHYSICS TEACHERS TECHNOLOGICAL
PEDAGOGICAL CONTENT KNOWLEDGE AND THEIR LEARNERS
ACHIEVEMENT IN ELECTRICITY

by

JONAS KWADZO KOTOKA

This certificate is issued without prejudice to the author on

28 January 2018

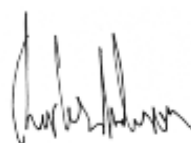

Charles Anderson
Director of Academic Editing
Editing Press Inc.
www.editing.press

Appendix 19

Similarity Report

Turnitin - Mozilla Firefox

https://www.turnitin.com/newreport.asp?eq=0&eb=0&esm=600&oid=976153919&svr=305&r=29.45254484896126&m=0&lang=en_us&bypass_cv=1

preferences



Originality Report

Processed on: 16-Jun-2018 12:42 SAST
ID: 976153919
Word Count: 27936
Submitted: 1

Document Viewer

Submission 2

By Jonas Kotoka

Similarity by Source	
Similarity Index	8%
Internet Sources:	9%
Publications:	2%
Student Papers:	6%

exclude quoted exclude bibliography excluding matches < 600 words mode: show highest matches together

INVESTIGATING PHYSICS TEACHERS' TECHNOLOGICAL PEDAGOGICAL CONTENT KNOWLEDGE AND THEIR LEARNERS' ACHIEVEMENT IN ELECTRICITY 1

by JONAS KWADZO KOTOKA submitted in accordance with the requirements for the degree of DOCTOR OF PHILOSOPHY IN MATHEMATICS, SCIENCE AND TECHNOLOGY EDUCATION in the subject PHYSICS EDUCATION at the UNIVERSITY OF SOUTH AFRICA SUPERVISOR: PROFESSOR JEANNE KRIEK 2

JANUARY 2018 DEDICATION

To my wife Love and our two children Gladys Yayra and Christian Delali 2

i ABSTRACT Student performance in science subjects does not augur well for South Africa's urgent requirements for skilled personnel in engineering, science, and technology. The purpose of this study is to investigates Physics teachers' (TPCK) and their learners' achievement in electricity. A purposive sample of 42 Grade 11 Physics teachers and 1457 learners 1

participated in the study. An explanatory mixed method

research design was employed in the study to collect data. A survey 1

1 5% match (Internet from 03-Jun-2017)
<http://www.saarmste.org>

2 4% match (Internet from 09-Oct-2017)
<http://uir.unisa.ac.za>