

Abbreviations

ALD:	anoxic limestone drains
AMD:	acid mine drainage
ARD:	acid rock drainage
BMP:	best management practices
COD:	chemical oxygen demand
CS:	control monitoring site
DENR:	Department of Environment and Natural Resources
DWAF:	Department of Water Affairs and Forestry
EC:	electric conductivity
EMPR:	Environmental Management Program Report
ERWAT:	East Rand Water Care Company
MAR:	mean annual runoff
NRM:	natural resource management
SASS5:	South African Scoring System version 5
SBR:	sequencing batch reactor
SOB:	sulphate oxidising bacteria
SRB:	sulphate reducing bacteria
SRP:	soluble reactive phosphorus
TDS:	total dissolved solids
TLS:	trained local samplers
TP:	total phosphorus
TWQR:	target water quality range
UV:	ultraviolet
WASI:	Wisconsin Agriculture Stewardship Initiative
WHO:	World Health Organisation
WMA:	Water Management Areas
WMS:	Water Management System
WRB:	West Rand mine Basin

Table of Contents

	<u>page</u>
Declaration	i
Acknowledgements	ii
Abstract	iii
Abbreviations	v
List of Figures	x
List of Tables	xii

Chapter 1 INTRODUCTION 1

1.1	Background to the study	1
1.2	Motivation for the study	2
1.3	Mining background	3
	1.3.1 Decant water	6
	1.3.2 Acid mine drainage	8
1.4	Study area	9
	1.4.1 Delimitation of study area	10
	1.4.2 The river	10
	1.4.3 An overview of the catchment	15
	1.4.4 Geohydrology	15
	1.4.4.1 Dolomite aquifers	16
	1.4.4.2 Weathered and fractured aquifers	18
1.5	Aim	18
1.6	Objectives	18
1.7	Research methodology	19
1.8	Organisation of chapters	20

Chapter 2 LITERATURE REVIEW 22

2.1	Introduction	22
2.2	Acid mine drainage	22
	2.2.1 Impacts	22
	2.2.2 Remediation	25
	2.2.2.1 Carbonate neutralisation	25
	2.2.2.2 Limestone	26
	2.2.2.3 Ion exchange	26
	2.2.2.4 Active treatment with aeration	26
	2.2.2.5 Precipitation of metal	27
	2.2.2.6 Constructed wetlands	28

2.3	Informal settlements	30
2.3.1	Impacts	31
2.3.2	Remediation	32
2.4	Sewage works	35
2.4.1	Impacts	35
2.4.1.1	Contaminants	37
2.4.1.2	Groundwater contamination	40
2.4.2	Remediation	42
2.4.2.1	Nitrogen removal	42
2.4.2.2	Phosphorus removal	42
2.4.2.3	Nutrient removal	43
2.4.2.4	Package plants and batch reactors	44
2.4.2.5	Constructed wetlands	45
2.5	Tailings dam	45
2.5.1	Impacts	45
2.5.2	Remediation	49
2.5.2.1	Embankment barriers	51
2.5.2.2	Tailings water treatment	52
2.5.2.3	Gilt Edge mine	54
2.6	Agricultural activity	56
2.6.1	Impacts	56
2.6.2	Remediation	62
2.6.2.1	Reduce total nitrogen loading	62
2.6.2.2	Mitigation and management options	63
2.7	Conclusion	69

Chapter 3 DATA COLLECTION AND DISCUSSION OF RESULTS 70

3.1	Introduction	70
3.2	Impacts	71
3.3	Water quality	72
3.3.1	Sampling	72
3.3.1.1	Description of monitoring sites	72
3.3.1.2	Background of monitoring points	75
3.3.1.3	Chemical analysis	77
3.3.2	Discussion	79
3.3.2.1.	pH	79
3.3.2.2	Conductivity	81
3.3.2.3.	Total dissolved solids and conductivity	82
3.3.2.4.	Sulphate	86
3.3.2.5	Nitrate	89
3.3.2.6	Alkalinity	92
3.3.2.7	Iron	94
3.3.2.8	Bacteriological analyses	96
3.3.2.9	Bio-monitoring	97

3.4	Water volumes	98
3.4.1	Volume of water flow	98
3.4.2	Evaporation and evapo-transpiration	99
3.4.3	Water balance	101
3.4.4	Vegetation cover	102
3.5	Impact of additional water	104
3.6	Conclusion	107

Chapter 4 EVALUATION OF REMEDIATION METHODS 109

4.1	Impacts identified through the literature review	109
4.1.1	Acid mine drainage	109
4.1.1.1	Carbonate neutralisation	109
4.1.1.2	Ion exchange	110
4.1.1.3	Active treatment with aeration	110
4.1.1.4	Precipitation of metal	110
4.1.1.5	Constructed wetlands	111
4.1.2	Informal settlements	113
4.1.3	Sewage treatment plants	114
4.1.4	Tailings dam	114
4.1.5	Agricultural activities	115
4.2	Best remediation option	116
4.3	Conclusion	116

Chapter 5 RECOMMENDATION FOR APPROPRIATE MITIGATION METHODS 117

5.1	Wetland capability	118
5.1.1	Combined wetlands	118
5.1.2	Aerobic wetlands	118
5.1.3	Anaerobic wetlands	119
5.2	Chemical remediation	121
5.2.1	Iron removal	121
5.2.2	Sulphates reduction	123
5.2.3	Nitrogen removal	126
5.3	Wetland design	127
5.3.1	Design considerations	127
5.3.1.1	Pre-treatment	128
5.3.1.2	Treatment	129
5.3.1.3	Conveyance	129
5.3.1.4	Maintenance reduction	130
5.3.1.5	Landscaping	130

5.3.2	Maintenance considerations	130
5.4	Site specific wetland requirements	132
5.4.1	Wonderfontein wetland design	134
5.4.2	Re-vegetation	135
5.4.3	Plant list selected for Wonderfontein wetland	137
5.5	Positioning of wetland	138
5.6	Delineation	140
5.6.1	Lining	140
5.6.2	Delineation methods	140
5.6.2.1	Soil form indicator	141
5.6.2.2	Soil wetness indicator	142
5.6.2.3	Vegetation indicator	143
5.6.2.4	Wetland indicators	145
5.7	Other mitigation methods	147
5.8	Conclusion	149
Chapter 6 CONCLUSION		150
6.1	Introduction	150
6.2	Summary of the study	150
6.3	Concluding comments	153
References		154
Appendix		170

List of Figures

<u>Figure</u>		<u>page</u>
1.1	UpperVaal water management area	2
1.2	Gold deposit of the Witwatersrand basin	4
1.3	Mineral deposit of Gauteng	5
1.4	Decant point and mine boundaries	6
1.5	Layout of study area: Northern point	7
1.6	Wonderfonteinspruit and surroundings	10
1.7	Upper Wonderfonteinspruit with relevant features	11
1.8	Cooke attenuation dam	12
1.9	Cooke tailings dam	13
1.10	Donaldson Dam: Upper end of upper Wonderfonteinspruit	14
1.11	Different catchments	15
1.12	Possible mechanism for recharge	17
2.1	Acid mine drainage discharge	23
2.2	Effluent from surface coal mine ('Yellow boy')	24
2.3	Illustration of a sewage plant	36
2.4	Results of water quality	39
2.5	Seasonal nitrate variations	59
2.6	Nitrogen forms and pathways within an agricultural production system	61
3.1a	Monitoring points of Wonderfonteinspruit (Overall view)	73
3.1b	Monitoring points of Wonderfonteinspruit (Study area)	74
3.2	pH Levels	80
3.3	Conductivity	84
3.4	Total dissolved solids	85
3.5	Sulphates	88
3.6	Nitrates	90
3.7	Alkalinity	93
3.8	Iron	95

<u>Figure</u>	<u>page</u>
3.9 Penman-Monteith equation	101
3.10 Water flow diagram for the study area	103
3.11 Examples of wetland vegetation cover	105
3.12 Cross sections of Wonderfonteinspruit	106
4.1 Criteria for an aerobic and anaerobic wetland design	112
4.2 Simplistic view of the planned wetland	116
5.1 Diagram of how a wetland works	117
5.2 Aerobic wetland	119
5.3 Anaerobic wetland	119
5.4 Wetland microbe habitat diversification via hydrophytes	120
5.5 Dynamics and transformations of nitrogen	127
5.6 Wetland design 1	132
5.7 Wetland design 2	133
5.8 Zones of a wetland	136
5.9 Chemical analysis for TDS and sulphate for Wonderfonteinspruit ...	139
5.10 Chemical analysis for iron and nitrate for Wonderfonteinspruit:	139
5.11 Mottling of water drenched soils	140
5.12 Soil variation for different sections in the wetland	143
5.13 Delineation lines of proposed wetland area	146

List of Tables

<u>Table</u>	<u>page</u>
2.1 Documented cases of wetlands acting as remediation measures for AMD and the removal of metals	29
2.2 Ideal range of water quality guidelines	40
3.1 Impact evaluation table	71
3.2 Water analysis of Wonderfonteinspruit	78
3.3 Results of bacteriological analysis	97
3.4 SASS results	98
3.5 Approximate water flow in the study area	99
3.6 Evapo-transpiration	101
3.7 Elevation of Wonderfonteinspruit with additional water	107
5.1 Ecosystem services supplied by wetlands	118
5.2 Ecosystem services delivered by wetlands	128
5.3 Regular maintenance activities for wetlands	131
5.4 Criteria for distinguishing different soil saturation	145

Chapter 1

BACKGROUND TO THE STUDY

1.1 Introduction

South Africa is an arid country with only 8.6% of the rainfall being available as surface water. This is one of the lowest conversion ratios in the world. The mean annual runoff (MAR) for South Africa is estimated at some 50 million m³ a⁻¹. Freshwater is our most limiting natural resource. South Africa receives only approximately half the average rainfall of other southern African countries and this is spread disproportionately across the country from east to west.

South Africa's available freshwater resources are already almost fully utilised and under stress. At the projected population growth and economic development rates, it is unlikely that the projected demand on water resources in South Africa will be sustainable. Water will increasingly become the single most limiting resource in South Africa, and supply will become a major restriction to the future socio-economic development of the country, in terms of both the amount of water available and the quality of available water resources. At present many water resources are polluted by industrial effluents, domestic and commercial sewage, acid mine drainage, agricultural runoff and solid waste (Midgley, Pitman & Middleton, 1994).

To augment supplies, South Africa is looking towards water sources in other southern African countries (e.g. Lesotho) to assist in providing sufficient water for projected future demands. However, the risks of international dependency on such a priority resource are high. Other possible sources of water, such as desalination of seawater and water from icebergs may be potential options in the long-term, although currently they are too expensive to exploit (Allanson, Hart, O'Keeffe & Robarts, 1990). It is imperative that South Africa develops both a water-efficient economy together with a social ethic of water conservation and ultimately a culture of sustainability of water resource use (Karr & Dudley, 1981).

As stated, one of the main culprits of water pollution is the mining industry. The West Rand is a major area of concern as it has the highest concentration of mining activities in the country (see *Figure 1.1* for locality and water management area).

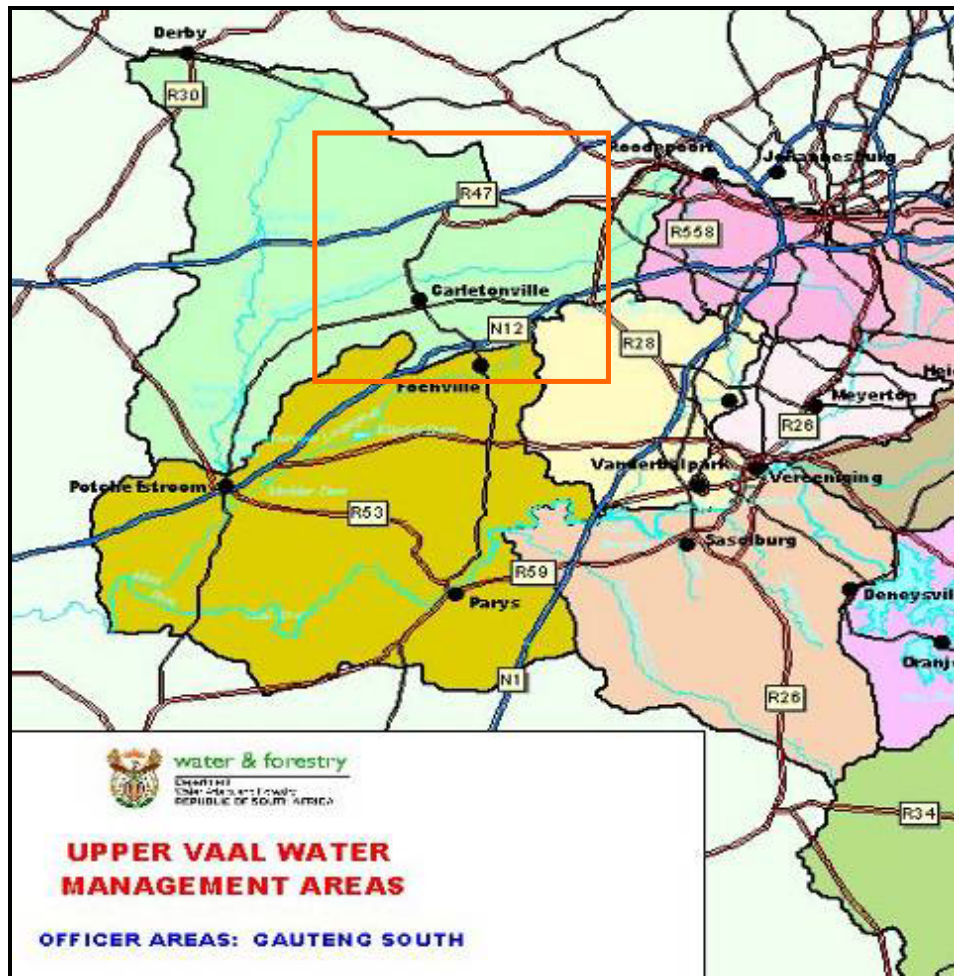

Figure 1.1 UpperVaal water management area
(Department of Water Affairs and Forestry, 2002)

Due to decanting of dormant mine shafts in the vicinity of the Wonderfonteinspruit, the water quality and volume are impacted on immensely.

1.2 Motivation for the study

Prior to initiation of any new mining operations, environmental impact assessments need to be done; thereafter the significant impacts identified are

addressed in an environmental management program report (EMPR). The mineral rights holder is legally obligated to implement the Environmental Management Program Report. Unfortunately no environmental management plan was drawn up for this specific problem. It is also true that decades of mismanagement and environmental neglect, led to an appalling image of the mining industry in the minds of the general public. If the full impact is recorded and management or rehabilitation methods are suggested, the mine can use this to not only remediate the environment but also to improve their public image. The surrounding population has the right to know the quality of their water resource on which they are dependant and to avoid any further degradation of the environment.

1.3 Mining background

Since a year after the discovery of gold on the Witwatersrand in 1886, the gold-bearing conglomerates of the Witwatersrand Supergroup have been mined on the West Rand in the Krugersdorp, Chamdor, Witpoortjie and Randfontein areas. The gold-bearing reefs outcrop along an east-west line following the railway line in the Krugersdorp area and curves progressively southwards around the axis of the West Rand Syncline towards the west until it runs almost entirely in a north-south direction in the Randfontein area (De Kock, 1964). This is illustrated in Figure 1.2.

Initially the reef outcrops were mined from the surface using primitive opencast methods. As mines got progressively deeper, opencast mining methods were replaced with shafts, initially incline shafts following the dip of the reef ($\pm 60^\circ$) and later vertical shafts designed to intersect the reefs at pre-determined depths.

In addition to the Witwatersrand reefs, Black Reef of the Transvaal Supergroup, overlying the Witwatersrand reefs and which is particularly deep in this area (deep valleys cut into the Witwatersrand Supergroup by ancient rivers that were subsequently filled in when the Transvaal Supergroup's Black Reef was being

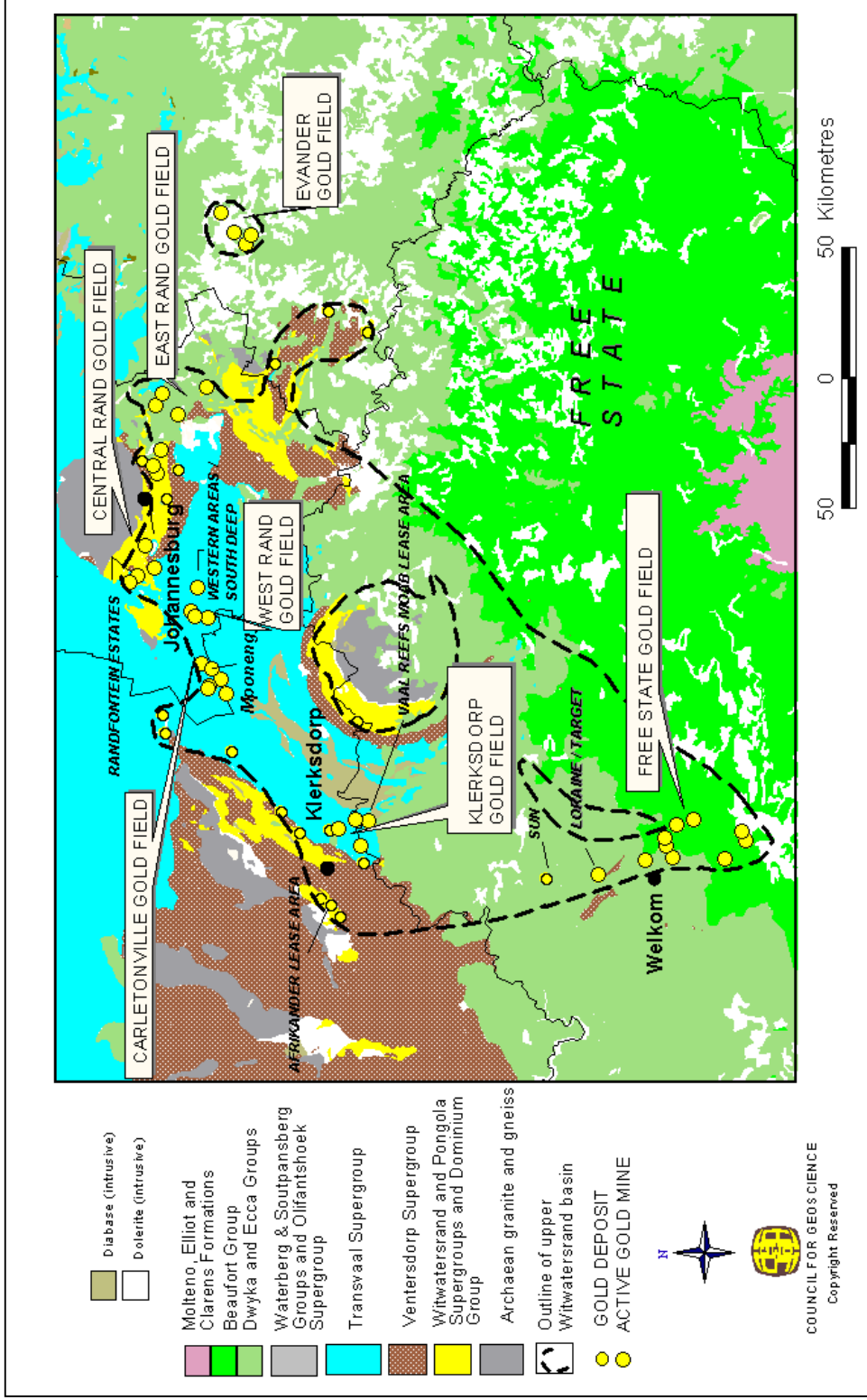

Figure 1.2 GOLD DEPOSITS OF THE WITWATERSRAND BASIN
(Council of Geosciences)

formed) between Randfontein and Krugersdorp (see *Figure 1.3* for a detailed geology map).

This area was mined within the catchment of the Cradle of Humankind World heritage site, mostly by modern opencast mining methods (Eriksson & Truswell, 1974).

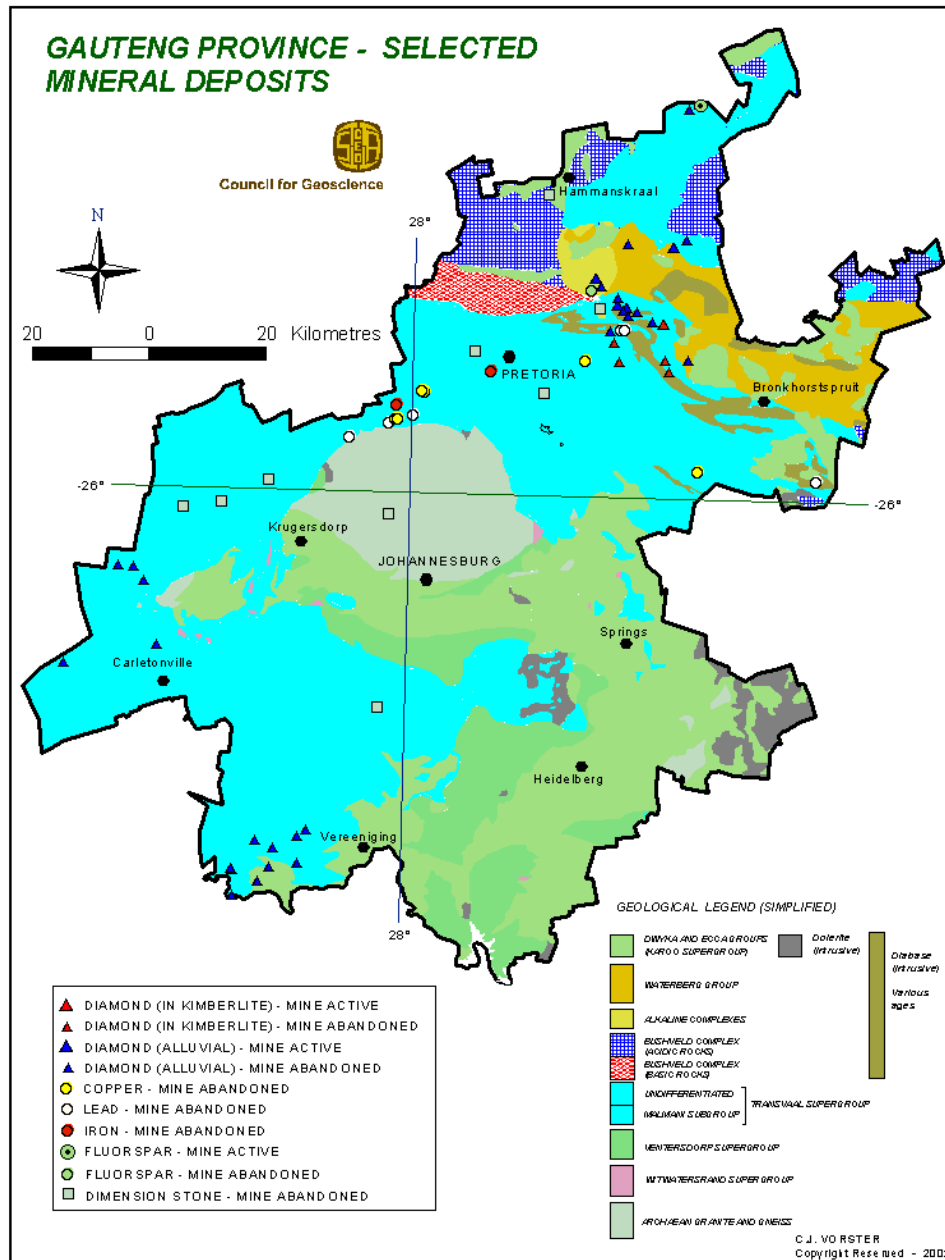

Figure 1.3 MINERAL DEPOSITS OF GAUTENG (Council of Geosciences)

As mines became deeper, increasing problems were experienced with water ingress into the underground workings of the mines. This water was pumped from the mine workings into the Tweelopiespruit. At the peak of mining an average daily volume of 32 000 m³ water was pumped from the Randfontein Estates. All this water eventually recharged into the Zwartkrans compartment. More than 100 years of mining created a combined mined-out void of 44 926 778 m³ (Eriksson & Truswell, 1974).

1.3.1 Decant water

When mining was discontinued in 2000, the defunct workings started to flood and in September 2002 the mine water started to decant from the Randfontein Estates (Old Section), West Rand Consolidated, Luipaardsvlei and East Champ D'Or Mines, collectively known as the West Rand Mine Basin (WRB) next to the Tweelopie East Stream. The decant point is at an elevation of 1662.98 metres above mean sea level (mamsl). Figure 1.4 indicates the mine boundaries and the decant point.

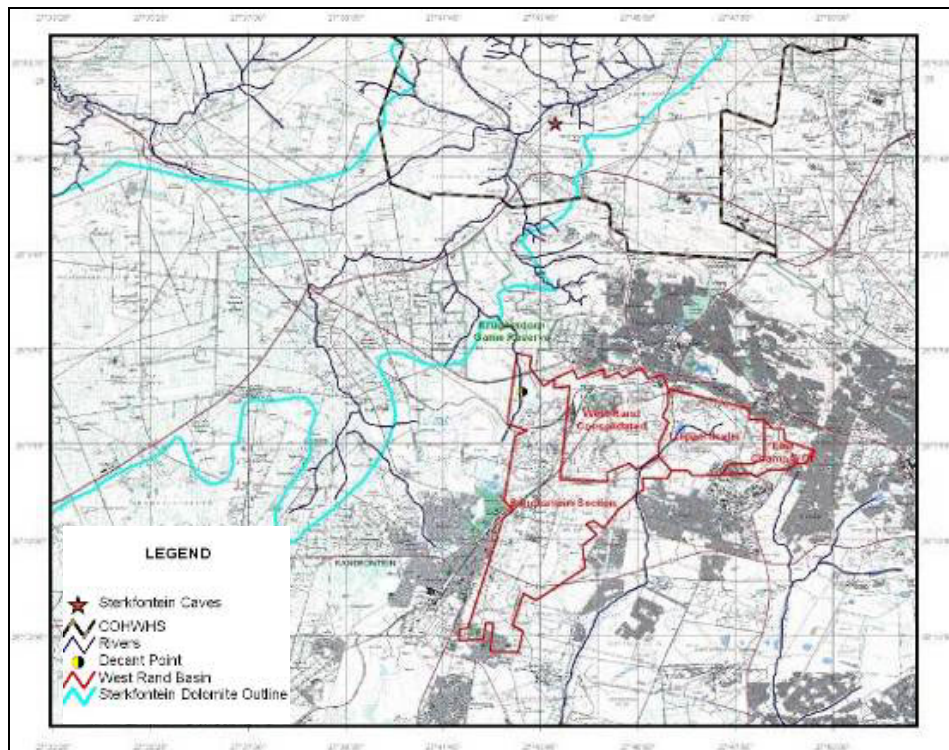

Figure 1.4 DECANT POINT AND MINE BOUNDARIES (Enpat GIS)

The water level in the mine void continued to rise even after the decant level was reached. This indicated that the Black Reef Incline is restricted and that the outflow at that point does not represent the inflow into the void. The current water table is at an elevation of 1671.75 mamsl, which is 8.77 m above the decant elevation.

This resulted in the Department of Water Affairs and Forestry (DWA) issuing a directive in terms of Section 19 (3) of the National Water Act of 1998 (Act 36 of 1998) to the mines responsible for creating the mine void. Section 2.1 of the Directive reads as follows: “From the date of this Directive, to collect and contain water decanting from the Western Mine Basin, treat it to standards laid down in paragraph (d) below and discharge it via a pipeline to the Attenuation Dam on the upper Wonderfonteinspruit at the Cooke Metallurgical Plant, which will discharge into the upper Wonderfonteinspruit under the following conditions: c) Discharge a maximum volume of only fifteen mega litres per day (15 MI/day) from the Attenuation Dam”.

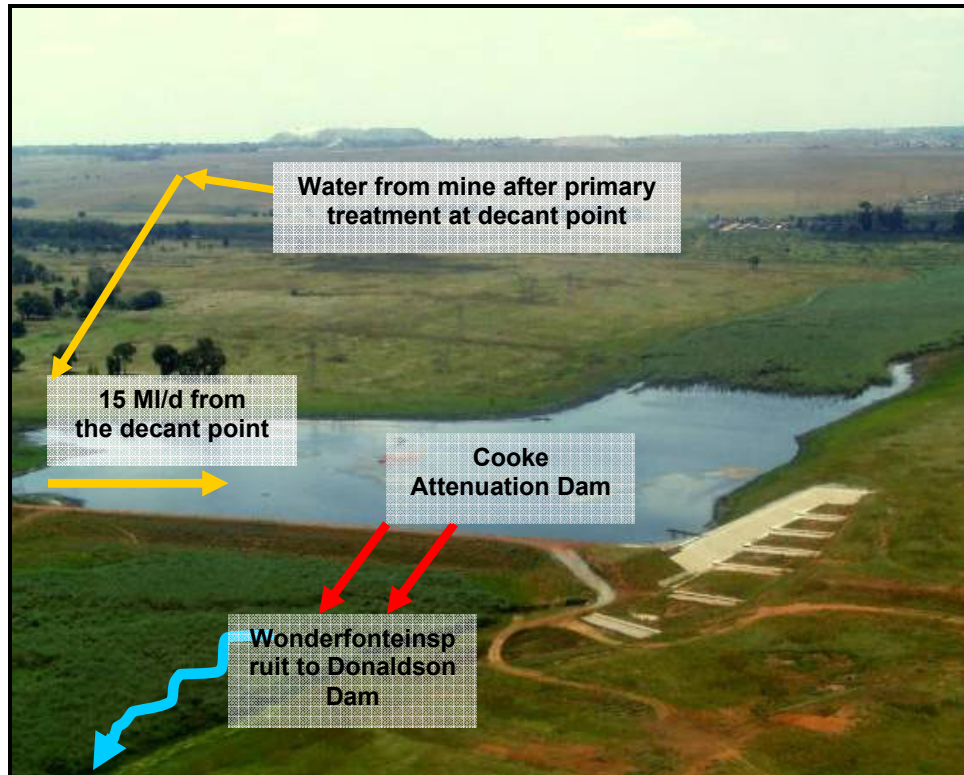

Figure 1.5 LAYOUT OF STUDY AREA: NORTHERN POINT

At present the mine decant water is treated through a process of lime addition and aeration, as well as secondary treatment through a wetland system. The treated water is currently used in the mine's metallurgical plants and 15MI per day of treated water is disposed firstly into the Cooke Attenuation Dam and then discharged into the Wonderfonteinspruit (see *Figure 1.5*).

1.3.2 Acid mine drainage

Apart from gold, a number of other metal-containing minerals are found along with gold in the gold-bearing Witwatersrand reefs. Of particular importance is the mineral, iron pyrites, more commonly referred to as "pyrite", for its properties to produce acid mine drainage (AMD), also sometimes referred to as acid rock drainage (ARD). Pyrite, with a chemical formula of FeS₂ (iron disulphide) is a sulphur-containing mineral. As long as pyrite remains buried deep underground within the rocks of the Witwatersrand and Transvaal Super groups, the sulphur remains in a stable, reduced state. However, when it is exposed to free oxygen in the presence of water, a series of chemical reactions occur, which ultimately give rise to the production of acidic water.

Acidic mine drainage (AMD) is an environmental pollutant of major concern in mining regions throughout the world. AMD occurs as a result of the oxidation of sulphide minerals when they are exposed to free oxygen and water during the mining process (Errington, 1991). In gold mining areas, the most common of these minerals is pyrite (FeS₂). The process for AMD formation is commonly represented by the following reactions:

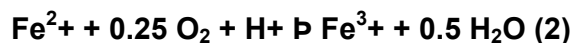

The process is initiated with the oxidation of pyrite and the release of ferrous iron (Fe²⁺), sulphate, and acidity (Eq. 1). The sulphide-oxidation process is accelerated by the presence of *Thiobacillus* bacteria. Ferrous iron then undergoes oxidation forming ferric iron (Fe³⁺) (Eq. 2). Finally, Fe³⁺ reacts with H₂O (is hydrolysed), forming insoluble ferric hydroxide (FeOOH), an orange-

coloured precipitate, and releasing additional acidity (Eq. 3). The FeOOH formation process is pH dependent and occurs rapidly when the pH is greater than 4 (Errington, 1991). The mining industry currently uses a pilot water treatment plant to increase the pH, and remove metals from the water. A permanent water treatment plant is planned in the near future, thus the water entering the Wonderfonteinspruit will be treated to industrial standard quality water and then discharged.

1.4 Study area

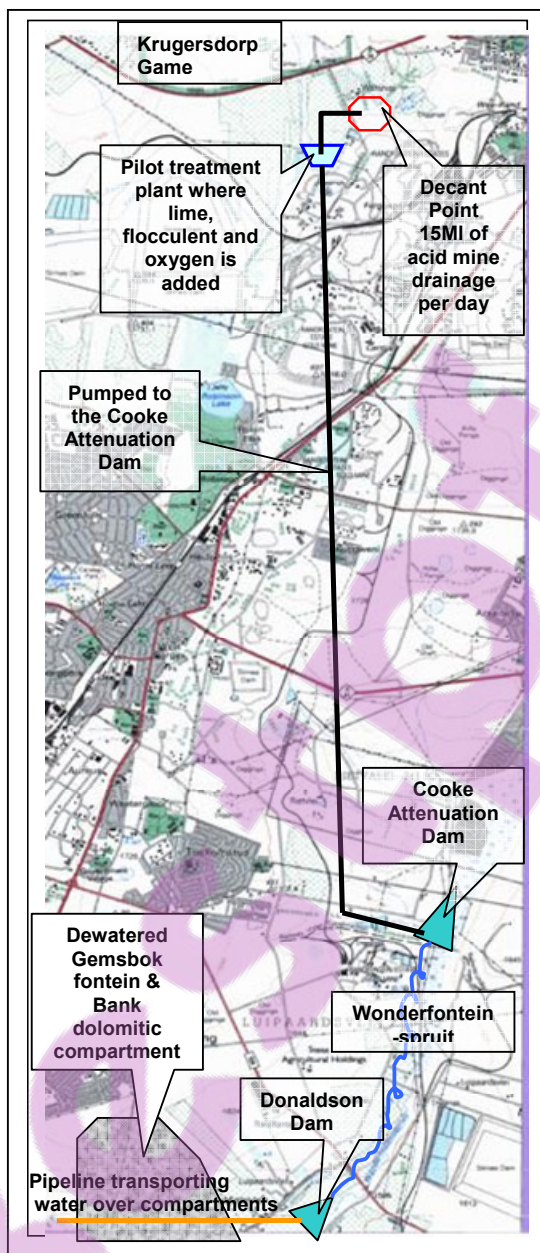

15MI per day of water decant at old mineshafts, it is then treated in a pilot treatment plant with lime, flocculent and oxygen is added. There after it is pumped to the Cooke Attenuation Dam. From here it flows through a constructed wetland and then it is pumped, through Wonderfonteinspruit, which feeds into the Donaldson dam at Westonarea. From the Donaldson Dam, the flow of the Wonderfonteinspruit is diverted into a pipeline, initially a 700 mm pipe for ± 1.5 km up to a weir and from there onwards, a 1-metre pipe. The entire length of the pipeline is ± 32.5 km up to Carletonville. The reason for the construction of the pipeline in the 1960's was to divert the flow of the Wonderfonteinspruit across the dewatered Gemsbokfontein and Bank dolomitic compartments. These compartments were dewatered to enable the mining of gold reefs below the dolomite.

1.4.1 Delimitation of study area

The study area covers a zone of approximately 500 m either side of the Wonderfonteinspruit and extends from the Cooke Attenuation Dam to the Donaldson Dam (see *Figure 1.6*).

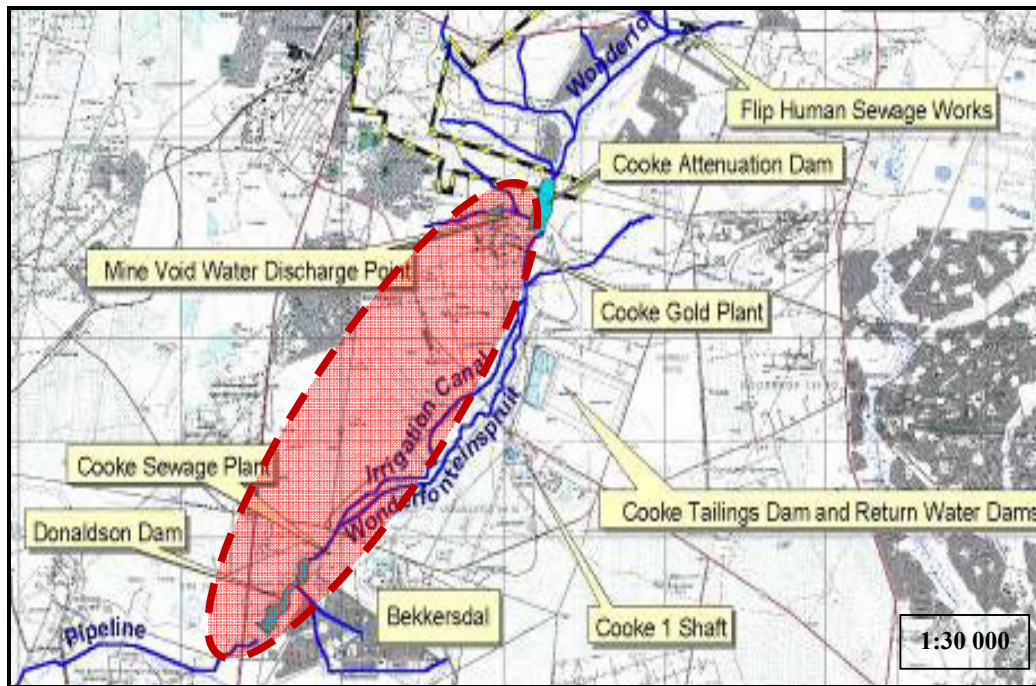

Figure 1.6 WONDERFONTEINSPRUIT AND SURROUNDINGS (Enpat GIS)

1.4.2 The river

Although no supporting documentation could be found, it can be assumed with a reasonable level of confidence that, before gold mining commenced, the stream probably was in a pristine condition, fed by perennial springs, hence the Afrikaans name of the stream meaning “*wonder fountain stream*” (see *Figure 1.7* for detailed layout).

The Wonderfonteinspruit has its origin in the Tudor Dam in Krugersdorp. This dam was used as a storage dam for the Luipaardsvlei Gold Plant. Some 2.3 km downstream from the Tudor Dam is the Lancaster Dam. This dam, too, was

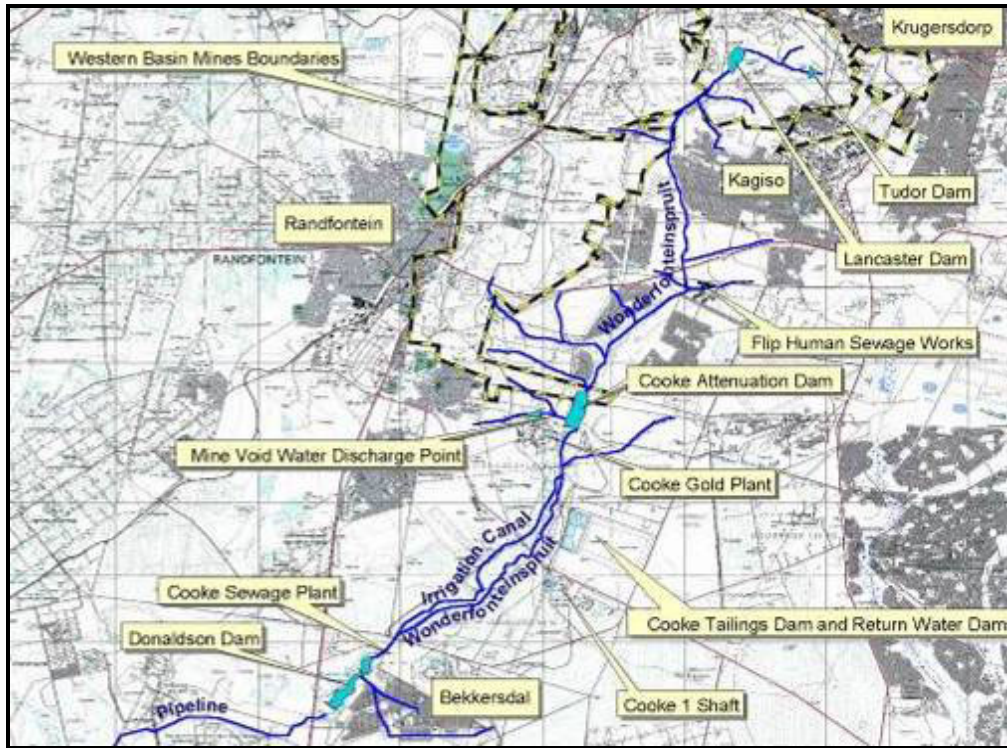

Figure 1.7 UPPER WONDERFONTEINSPRUIT WITH RELEVANT FEATURES

used as a storage dam for the plant. During its lifetime, it became totally silted up. As a result of spillages from the plant, the sediment in the dam contained relatively high grades of gold, making mining of the dam viable.

The Mogale Gold Company mined the sediments of this dam during 2003/04 up to the time they were placed under judicial management. All mining operations then ceased, leaving the dam in a poor state with newly exposed sediment deposits subjected to weathering and erosion, creating a renewed pollution source for the part of the stream downstream from the dam.

In the township of Kagiso, the Wonderfonteinspruit widens for a distance of 1.5 km and flows through a reed bed up to 350 m wide in places. This reed bed has had a beneficial impact on the contaminated water originating in the gold mining area and also prevents the siltation originating from the gold mining industry spreading further downstream. A small stream enters the

Wonderfonteinspruit from the east around the centre of this section of the Wonderfonteinspruit. This stream drains a low-cost housing area and transports poor quality surface run-off water (high COD and bacteriological counts) to the Wonderfonteinspruit.

After the Witpoortjie fault, the Wonderfonteinspruit narrows and flows in a channel across the quartzites and shales of the Witwatersrand Super group for a distance of approximately 2.5 km up to the point where the Flip Human Sewage Plant of the Mogale City Local Municipality discharges its effluent. From the Flip Human Sewage Plant, the Wonderfonteinspruit flows through an extensive reed bed for a distance of approximately 4.8 km. In places, this reed bed is over 500 m wide. This section of the Wonderfonteinspruit ends in the Cooke Attenuation Dam (see *Figure 1.8*).



Figure 1.8 COOKE ATTENUATION DAM

Fifteen (15) Ml of treated Western Basin mine void water is discharged into this dam daily. This water originates from the decant point in the Tweelopiespruit where contaminated water flows from an Old Black Reef incline. The mining impact comes from Harmony Gold Mining Co Ltd Randfontein Operations.

Harmony has a gold plant named the Cooke Plant immediately downstream from the Cooke Attenuation Dam on the western side of the stream (see *Figure 1.8* showing the Cooke Plant on the banks of the Wonderfonteinspruit).

Some 2 km downstream from Cooke Plant is the Cooke tailings dam on the eastern side of the stream. Tailings material is pumped across the stream from Cooke Plant to the tailings dam. As in the case of Cooke Plant, this tailings dam often causes spillages into the Wonderfonteinspruit (see *Figure 1.9*).



Figure 1.9 COOKE TAILINGS DAM

About 1.5 km downstream from the Cooke tailings dam is the Cooke 1 shaft. Surplus underground water is discharged into the Wonderfonteinspruit from this shaft. It is then understandable that the sulphate concentration would rise as the Wonderfonteinspruit passes these point pollution sources. From the Cooke 1 shaft, the Wonderfonteinspruit traverses another 5.7 km before reaching its last impoundment before entering a 1-metre diameter pipeline. This is the Donaldson Dam. The Donaldson Dam actually comprises two separate dams, an upper and lower dam. It has a storage capacity of approximately 1 000 MI (see *Figure 1.10*).



Figure 1.10 DONALDSON DAM: END OF UPPER WONDERFONTEINSPRUIT

The township in the foreground is part of the squatter camp of Bekkersdal. Both upper and lower parts of the Donaldson Dam are clearly visible in this photograph. From the Donaldson Dam, the flow of the Wonderfonteinspruit is diverted into a pipeline across the dewatered dolomitic compartments, initially a 700 mm pipe for approximately 1.5 km up to a weir and from there onwards, a 1-metre pipe. The entire length of the pipeline is approximately 32.5 km up to Carletonville.

The Wonderfonteinspruit continues over the West Rand Group up to the Cooke Attenuation Dam. After the dam, the stream crosses briefly onto a narrow section of Black Reef of the Chuniespoort Group, Transvaal Supergroup before flowing onto the dolomite of the Malmani Subgroup, Chuniespoort Group and Transvaal Supergroup. From here it remains on the dolomite up to the Donaldson Dam. In fact, it remains on dolomite all the way past Carletonville. The Donaldson Dam, however, represents the end of the study area.

1.4.3 An overview of the catchment

The Wonderfonteinspruit forms part of the Mooi River catchment system, which in turn, forms part of the Vaal River catchment. The Wonderfonteinspruit comprises quaternary catchment C23D. This catchment has a surface area of 460.94 km², a mean annual precipitation of 663.5 mm with a reported mean annual run-off into surface streams of 29.5 mm (Midgley *et al.*, 1994). The different catchments are indicated in Figure 1.11.

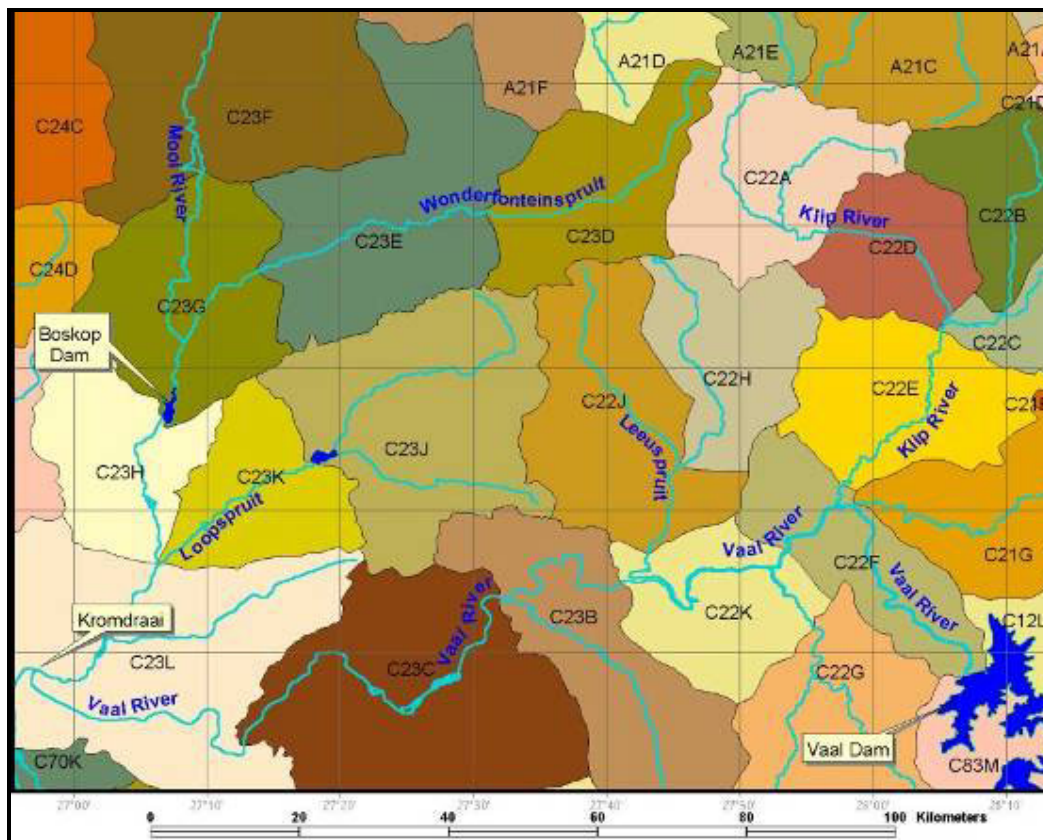

Figure 1.11 DIFFERENT CATCHMENTS

1.4.4 Geohydrology

The water originally flowing in the Wonderfonteinspruit resulted from the succession of dolomite springs and was of an extraordinary quality, despite mining in the headwater of the valley until the early 1960s. Mining activities required the pumping of dolomitic water entering the mine workings, which resulted in surface instability and the formation of sinkholes. In order to curtail

the formation of sinkholes, Government during the 1960's mandated the dewatering of some compartments. Dewatering of these compartments was considered a necessity to continue mining at various mines in the area. As a result, the underground water was discharged into the Wonderfonteinspruit by these mines. The dewatering of underground compartments resulted in severe impacts on both quality and quantity of the Wonderfonteinspruit (Midgley *et al.*, 1994). Groundwater occurrences in the study area are predominantly restricted to weathered and fractured rock aquifer in the Witwatersrand and Black Reef Formations and a Zuurbekom Dolomitic Groundwater Compartment.

1.4.4.1 Dolomite aquifers

Dolomite aquifers are known to contain large quantities of groundwater and are commonly associated with sustainable groundwater abstraction. Such a dolomite aquifer underlies the study area and is known as the Zuurbekom Dolomite Groundwater Compartment. The area south of the Doornkop fault is covered by the Malmani Dolomite, which is locally known as the Zuurbekom Dolomite Compartment. The Kliprivier Dyke in the east, the Panvlakte Dyke in the south and the Magazine Dyke in the west mark the boundaries of the Zuurbekom–East Compartment.

The sub-outcrop of the dolomite against the Doornkop fault marks the northern boundary. The Zuurbekom–East Groundwater Compartment, which underlies the largest part of the study area, is a non-dewatered compartment, although significant abstraction is taking place by a Rand Water borehole. The latter is used to supplement the water supply to the greater Johannesburg.

Due to extensive erosion only the lowermost Oaktree Formation is present in the study area. This formation consists of chert-poor homogeneous dark-grey dolomite with interbedded carbonaceous shale. The dolomite has a gentle regional dip to the south and attains a total thickness of approximately 200m (Parsons, 1990) in the study area. As a result of superficial deposits, the dolomites are not visible on the surface.

About 1300 Ma ago, the region was subjected to tension resulting in the formation of a number of large north to north-easterly striking faults. Many of the faults penetrated the full Transvaal sequence, as well as the underlying Ventersdorp and Witwatersrand Supergroups. Some of the faults were filled by Pilansberg age dykes, which subdivided the dolomite into the above-mentioned watertight compartments. The Zuurbekom–East groundwater compartment is further divided into sub-compartments by a number of smaller dykes, identified during an aero magnetic geophysical investigation and with limited hydraulic connectivity with each other (Brink, 1979).

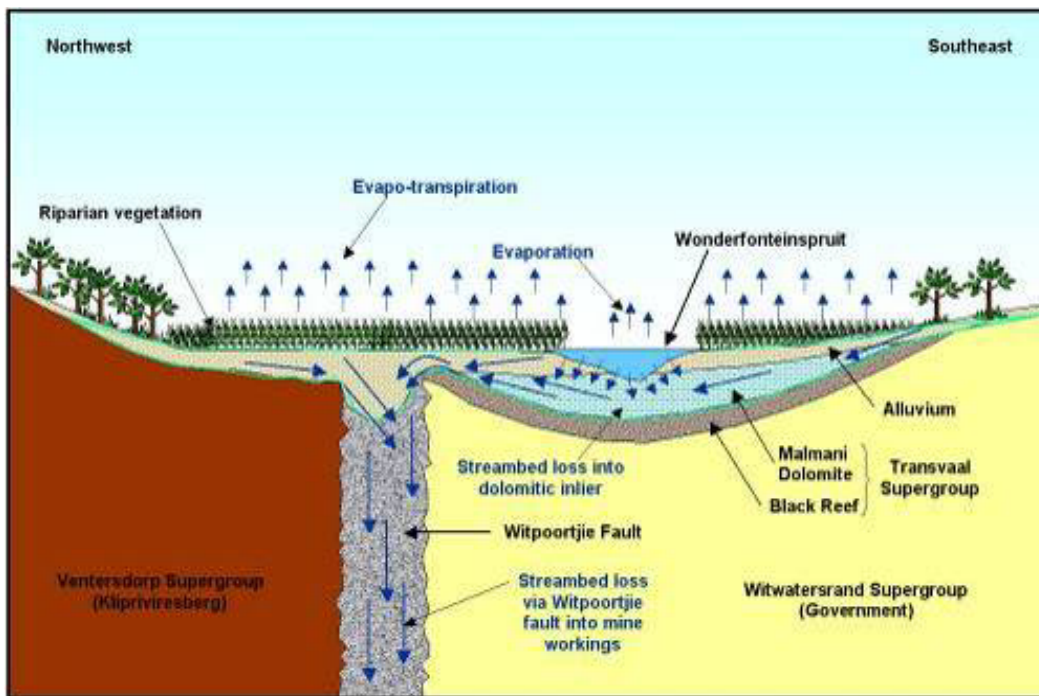

Figure 1.12 POSSIBLE MECHANISM FOR RECHARGE

The weathered dolomite, together with its dissolution products (wad) forms the main aquifer in the area. The extent of the aquifer was determined through a regional gravity survey, which clearly illustrates areas of deeper weathering or paleo-karst valleys. Figure 1.12 is a schematic representation of the possible mechanism through which river water from the Wonderfonteinspruit recharges into the Western Basin mine void (interpreted)

1.4.4.2 Weathered and fractured aquifers

The rocks of the Witwatersrand Super Group and Black Reef Formation are not considered to contain economic and sustainable aquifers. Localised high yielding boreholes may however exist where fractures are intersected. Groundwater occurrences are mainly restricted to the weathered formations, although fracturing in the underlying “fresh” bedrock may also contain water. Experience has shown that these open fractures seldom occur deeper than 60 m. The base of the aquifer is the impermeable quartzite and shale formations within these formations, whereas the top of the aquifer would be the surface topography. The groundwater table is affected by seasonal and atmospheric variations. The aquifer is therefore classified as semi-confined. The aquifer parameters, which includes transmissivity and storativity is considered to be low and groundwater movement through this aquifer is therefore also slow (Brink, 1979).

1.5 Aim

To identify and recommend remediation measures resulting from surface water contamination on the quality and volume of the water in the Wonderfonteinspruit.

1.6 Objectives

In order to achieve the abovementioned aim, the following objectives have been stated for the research namely:

- Identify factors impacting on the water quality and volume in the Wonderfonteinspruit;
- Investigate the resultant impacts;
- Evaluate alternative solutions to the impacts determined;
- Propose remediation measures to mitigate the impacts.

1.7 Research methodology

To determine the various impacts on the Wonderfonteinspruit, initial personal interviews were done with the local residents in the two townships, as well as with the environmental manager and primary-treatment supervisor of the mines.

To establish the water quality impact, water samples were taken at the monitoring points throughout the Wonderfonteinspruit (MS1 – MS13). Sterile sampling bottles were obtained from DD Science cc Laboratory for collecting water samples for chemical analyses and water samples for bacteria analyses, while sterile sample sachets were used for sediment samples. The water quality was analysed to establish the impacts from several informal settlements, as well as the Flip Human sewerage treatment facility, the tailings dam and other factors, located on the banks of the Wonderfonteinspruit. The macro-invertebrate assemblage gives a good indication of the biological health of an aquatic environment. The macro-invertebrate assessment was made using the SASS5 (South African Scoring System version 5) method.

The volume of water flow was measured at strategic sites to assist in calculating the load of chemical composition and loss or accumulation of water in the system. Due to the fact that an accurate flow-measuring device was not available at the time of this survey, approximate flow values were calculated by measuring the volume of water passing a specific point in a given time. The Manning formula was used to calculate flow at culverts. Water balance calculations of the groundwater monitoring boreholes in the area, was done using the water balance equation as presented by Bredenkamp, van der Westhuizen, Wiegman & Kuhn (1986).

Other impact on the volume due to evapo-transpiration was calculated by using the A-Pan formula. The vegetation cover of the study area and the vegetation composition of the Wonderfonteinspruit was assessed by collection and identification along this axis following the route of the stream, where possible, using the monitoring sites as points of reference.

Aerial photographs were visually interpreted to determine other impacts in the vicinity, like agricultural or industrial activities, township size and mining facilities. Spatial data was collected, analysed and plotted to better understand and to visualise the investigation.

1.8 Organisation of chapters

Chapter 1 will inform the reader about the background of surface water contamination related to the historical mining in the area, and provide a background to the study area in order to better understand the impacts. The aims and objectives of and research methodology for the study are also included.

The literature review of all the different identified impacts forms the basis of Chapter 2 and three questions relating to the different impacts provide the background to the literature review. The three questions relate to the impacts on water quality and volume: 1) what is nature of the contamination? 2) what is the impact on the water quality and volume? 3) what possible mitigation methods are there? The literature gives some indication of the impacts that might be expected.

In Chapter 3 the data collected in terms of the impacts is analysed and the results reported and discussed. The main contributors of contamination are identified, and the contamination is then examined to inform and guide the search for an appropriate treatment.

Chapter 4 discusses all the alternative remediation methods that emanate from the literature review, taking into consideration efficiency, cost and site-specific requirements.

Chapter 5 recommends appropriate remediation methods relating to the impacts identified.

The last chapter, Chapter 6, provides a synthesis of the entire study, highlights the most important findings of the study and reviews the proposed remediation measures that would best address the identified impacts.

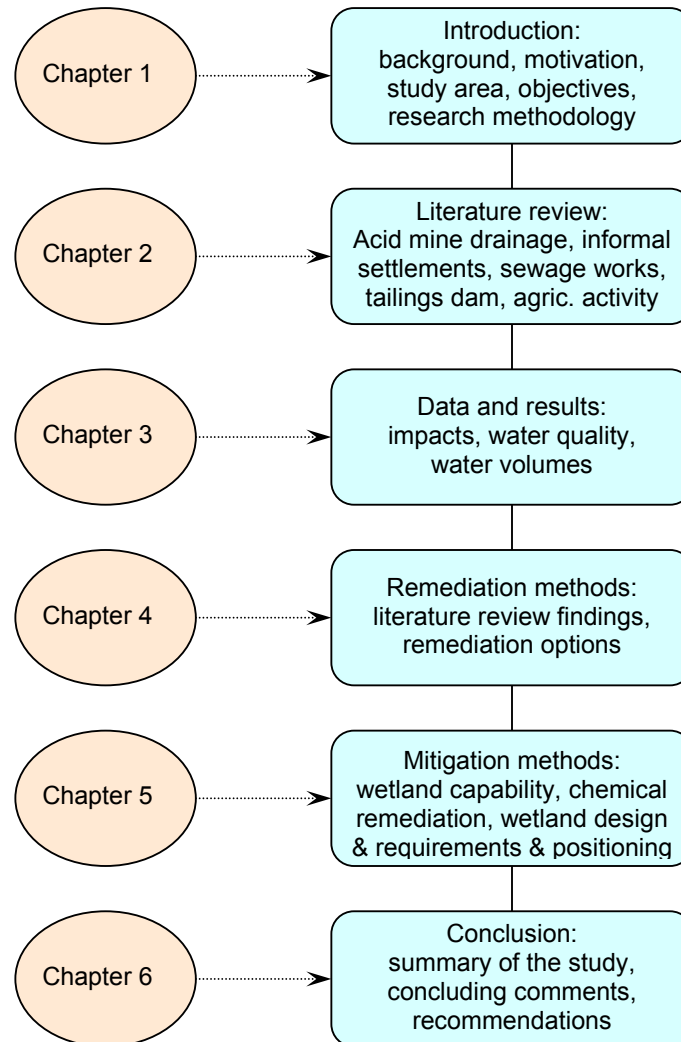

Chapter 2

LITERATURE REVIEW

2.1 Introduction

After a detailed desktop study, examination of aerial photographs/topocadastral maps and interviews, five main contributors to the contamination of the Wonderfonteinspruit were identified. These are acid mine drainage from the decant point, informal townships, the Flip Human sewage works, the tailings dam and some agricultural activities taking place along the river. The literature review focuses on the different impacts possibly resulting from the contaminators. Possible mitigation methods that have been applied throughout the world are also highlighted.

2.2 Acid mine drainage

Acid mine drainage (AMD), or acid rock drainage (ARD), refers to the outflow of acidic water from (usually) abandoned metal mines or coalmines. ARD occurs naturally within some environments as part of the rock weathering process but is exacerbated by large-scale earth disturbances characteristic of mining and other large construction activities, usually within rocks containing an abundance of sulphide minerals (Wildeman, Gusek & Brodle, 1991). This chapter will only focus on AMD as it is the main contributing factor to the deterioration of the Wonderfonteinspruit water quality.

2.2.1 Impacts

Sub-surface mining often progresses below the water table, so water must be constantly pumped out of the mine in order to prevent flooding. When a mine is abandoned, the pumping ceases, water levels rise and flood the underground portions of the mine. After being exposed to air and water, oxidation of metal sulphides (often pyrite, which is primarily composed of iron-sulphide) within the

surrounding rock and overburden generate acidity. AMD is characterised by high sulphate concentrations, high levels of dissolved metals and the pH is generally <4.5. The chemistry of the oxidation of pyrites, the production of ferrous ions and subsequently ferric ions, is very complex, and this complexity has considerably inhibited the design of effective treatment options. Although a host of chemical processes contribute to AMD, pyrite oxidation is by far the greatest contributor. A general equation for this process is:



The solid pyrite, when introduced to oxygen and water, is catalysed to form iron (II) ions, sulphate ions, and hydrogen ions. The hydrogen ions bind to the sulphate ions to produce sulphuric acid (Hedin, Watziaf & Naim, 1994). In some AMD systems temperatures reach 50°C, and the pH can be as low as 3.6. Figure 2.1 illustrates acid mine drainage.



Figure 2.1 ACID MINE DRAINAGE DISCHARGE
(Photograph of the Tinto River, USA. Credit - Carol Stoker)

Figure 2.2 illustrates the so-called 'Yellow boy' in a stream receiving acid drainage from surface coal mining. When the pH of AMD is raised past 3, either through contact with fresh water or neutralising minerals, soluble iron (II) ions hydrolyse to form iron (III) hydroxide, a yellow-orange solid colloquially known as 'Yellow boy'. 'Yellow boy' discolours water and smothers plant and animal life on the streambed, disrupting stream ecosystems. The process also produces additional hydrogen ions, which can further decrease the pH (Hedin, 1994).



Figure 2.2 EFFLUENT FROM SURFACE COAL MINES ('Yellow boy')

Photograph of Missouri stream, USA

(Credit – D. Hardesty, USGS Columbia Environmental Research Center)

The iron hydroxides ('yellow boy') that precipitate in pond treatment systems may be a valuable resource. The idea to recover the iron has been around at least since the turn of the century and is now becoming a reality. The iron hydroxides

deposited in passive pond treatment systems are consistently very high in iron content, and are being proposed for use in sewage treatment, as pigment, as colorants in construction material, and other uses. Research is currently being conducted into the feasibility of using 'yellow boy' as a commercial pigment (Sikora, Behrends, Brodie & Bulls, 1996).

2.2.2 Remediation

In research done worldwide five main treatment options were identified for acid mine drainage namely:

- Carbonate neutralisation,
- Ion exchange,
- Active treatment with aeration,
- Precipitation of metal,
- Constructed wetlands.

These five treatment options will be discussed in more detail in order to establish the suitability of these treatment methods for this study (these treatment options will be analysed and the best alternative will be selected as remediation method in Chapter 4).

2.2.2.1 Carbonate neutralisation

Generally, limestone or other calcareous strata that could neutralise acid are lacking or deficient at sites that produce acidic rock drainage. Limestone chips may be introduced into sites to create a neutralising effect (Ziemkiewicz, Skousen & Lovett, 1994). Where limestone has been used, such as at Rheidol in mid Wales, the positive impact has been much less than anticipated because of the creation of an insoluble calcium sulphate layer on the limestone chips, coating the material and preventing further neutralisation.

2.2.2.2 Limestone

Limestone is a cost effective way to control the pH of the acid mine drainage if no primary treatment occurs. Settling ponds at the primary treatment plant holds all the iron (III) hydroxide ('yellow boy') that is disposed of on appropriate sludge dams at a later stage (Ziemkiewicz *et al.*, 1994).

2.2.2.3 Ion exchange

The first relates to the GYP-CIX process, which uses the well-known cation and anion exchange resins to absorb from the AMD, cations (e.g. Ca^{++}) and anions (SO_4^-) by exchanging them for hydrogen and hydroxide ions respectively. This is a well-known method to de-ionise solutions. When the resins are fully loaded with the pollutants, they have to be regenerated with an acid and an alkali respectively (Henrot & Wieder, 1990). The cost of ion exchange materials compared to the relatively small returns, as well as the inability of current technology to efficiently deal with vast amounts of effluent has made it unviable.

2.2.2.4 Active treatment with aeration

In some discharges, HCO_3^- , a base, enters into run-off from the breakdown of organic matter in the mine, such as mine timbers, or from the groundwater interaction with limestone. The base then neutralises the acid in the run-off, forming carbonic acid.

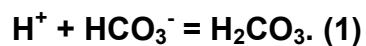

When this solution reaches the ground surface, the water is exposed to the air and the dissolved CO_2 will degas into the atmosphere. This lowers the concentration of CO_2 , allowing more H_2CO_3 to decompose, which in turn allows the neutralisation of more acid.



The increase in the pH promotes the oxidation of the iron and the formation of iron hydroxide, which will precipitate out of the solution, leaving little iron left in the water. Large aeration systems can be used to allow more CO₂ to outgas, and thus precipitate more iron out of the solution. This method however only works for runoff, which is naturally alkaline (Moshiri, 1993).

2.2.2.5 *Precipitation of metal*

Enough alkalinity must be added to raise water pH and supply hydroxides (OH⁻) so dissolved metals in the water will form insoluble metal hydroxides and settle out of the water. The pH required to precipitate most metals from water, ranges from pH 6 to 9 (except ferric iron which precipitates at about pH 3.5). The types and amounts of metals in the water therefore heavily influence the selection of an AMD treatment system. Ferrous iron converts to a solid bluish-green ferrous hydroxide at pH >8.5. In the presence of oxygen, ferrous iron oxidises to ferric iron, and ferric hydroxide forms a yellowish-orange solid, which precipitates at pH >3.5.

In oxygen-poor AMD where iron is primarily in the ferrous form, enough alkalinity must be added to raise the solution pH to 8.5 before ferrous hydroxide precipitates. A more efficient way of treating high ferrous AMD is to first aerate the water (also outgassing CO₂), causing the iron to convert from ferrous to ferric, and then adding a neutralising chemical to raise the pH to 6 or 7 to form ferric hydroxide. Aeration after chemical addition is also beneficial. Aeration before and after treatment usually reduces the amount of neutralising reagent necessary to precipitate iron from AMD. Aluminium (Al) hydroxide generally precipitates at pH > 5.0 but also enters solution again at a pH of 9.0 (Brant & Ziemkewicz, 1997).

Manganese precipitation is variable due to its many oxidation states, but will generally precipitate at pH of between 9.0 and 9.5. Sometimes, however, a pH of 10.5 is necessary for complete removal of manganese. As this discussion demonstrates, the appropriate treatment chemical can depend on both the oxidation state and concentrations of metals in the AMD. Interactions among

metals also influence the rate and degree to which metals precipitate. For example, iron precipitation will largely remove manganese from the water at a pH 8 due to co-precipitation, but only if the iron concentration in the water is much greater than the manganese content (about 4 times greater) (Sikora *et al.*, 1996).

If the iron concentration in the AMD is less than four times the manganese content, manganese may not be removed by co-precipitation and a solution pH >9 is necessary to remove the manganese. Because AMD contains multiple combinations of acidity and metals, each AMD is unique and its treatment by these chemicals varies from site to site. For example, the AMD from one site may be completely neutralised and contain no dissolved metals at a pH of 8.0, while another site may still have metal concentrations that do not meet effluent limits even after the pH has been raised to 10 (Sikora *et al.*, 1996)

2.2.2.6 Constructed wetlands

Constructed wetlands systems have shown promise as a more cost-effective treatment alternative to artificial treatment plants. A spectrum of bacteria and archaea, in consortium with wetland plants, may be used to filter out heavy metals and raise the pH. Anaerobic bacteria in particular are known to be capable of reverting sulphate ions into sulphide ions. These sulphide ions can then bind with heavy metal ions, precipitating heavy metals out of solution and effectively reversing the entire process (Skovran & Clouser, 1998).

Huntsman, Solch and Porter (1978) and Wieder and Lang (1982) first noted the potential of wetlands to ameliorate AMD, following passage of AMD through the naturally occurring *Sphagnum* bogs in Ohio and West Virginia. Studies by Brooks, Samuel (1985) and Samuel, Sencindiver and Rauch (1988) documented similar phenomena in *Typha sp.* wetlands. Although evidence suggests that some wetland plants show long-term adaptation to low pH and high metal concentrations, AMD eventually degrades the quality of natural wetlands, which is contrary to federal laws designed for wetland protection and enhancement. Such regulations do not

govern the use of artificially constructed wetlands for water treatment, leading to the suggestion that these engineered systems might provide low cost, low maintenance treatment of AMD (Kleinmann, 1991). Over a thousand wetlands have since been constructed to ameliorate AMD from both active mines and abandoned mine lands.

Table 2.1 DOCUMENTED CASES OF WETLANDS ACTING AS REMEDIATION MEASURES FOR AMD AND THE REMOVAL OF METALS (Brodie, 1991)

Mine	Location	AMD	Contaminants removed	Reference
United Keno Hill Mines	Yukon Territory, Canada	No	Zn	Boyle, 1965
Unnamed coal mine	West Virginia, USA	Yes	Fe, Mn	Wieder & Lang, 1982
Mt. Washington	British Columbia, Can	Yes	As, Cu, Zn (Limited)	Kwong & Van Stempvoort, 1994
Carbonate Mountain	Montana, USA	Yes	Al, Fe, Pb	Dollhopf <i>et al.</i> , 1988
Dunka Mine	Minnesota, USA	No	Cu, Ni	Eger & Lapakko, 1988
Star Lake, Jolu Mines	Saskatchewan, Canada	No	Cu, cyanide	Gormely <i>et al.</i> , 1990
Natural wetlands at 35 coal mines	Pennsylvania, USA	Yes	Al, Fe, Mn	Stark, 1990
Unnamed coal mine	Pennsylvania, USA	Yes	Fe, Mn	Tarutis <i>et al.</i> , 1999
Con Mine	Northwest Territories, Canada	No	As, Cu, cyanide	Ball, 1993
Quirke Mine	Ontario, Canada	No	Fe, Ra-226	Davé, 1993
Ranger Mine	Jabiru, Australia	No	U	Noller <i>et al.</i> , 1994
Tom's Gully Mine	100 km S.E. of Darwin, Australia	No	As, Cu, Co, Fe, Mn, Ni, Pb, U, Zn	Noller <i>et al.</i> , 1994
Hilton Mine	Mt Isa, Queensland, Australia	No	Fe, Mn, Tl, Zn	Jones and Chapman, 1995
Woodcutters Mine	80 km south of Darwin, Australia	No	Cd, Mn, Pb, U, Zn	Noller <i>et al.</i> , 1994
United Keno Hill Mines	Yukon Territory, Canada	No	Zn	Sobolewski, 1995
Birchtree Mine	Manitoba, Canada	No	Ni	Hambley, 1996
St. Kevin Gulch	Colorado, USA	Yes	Fe [yes], Zn [no]	Walton-Day, 1993

The case for wetland treatment systems becomes more compelling when this evidence is assembled. Table 2.1 provides a summary of documented cases of natural wetlands that improved mine drainage and the contaminants the wetland removed.

Chemical reactions (hydrolysis) and biologically driven reactions (formation of insoluble sulphides and carbonates) primarily account for the removal of metals and their retention in sediments. Neutralisation of acidic water within wetlands results from biological production of bicarbonate. The only maintenance these otherwise "passive treatment systems" may require is the periodic removal of precipitates accumulating in sedimentation ponds (Kotze, 1996).

2.3 Informal settlements

Informal settlements (often referred to as squatter settlements or shanty towns) are dense settlements comprising communities housed in self-constructed shelters under conditions of informal or traditional land tenure. They are common features of developing countries and are typically the product of an urgent need for shelter by the urban poor. As such they are characterised by a dense proliferation of small, make-shift shelters built from diverse materials, degradation of the local ecosystem and by severe social problems (Mazur, 1995).

Informal settlements occur when the current land administration and planning fails to address the needs of the whole community. These areas are characterised by rapid, unstructured and unplanned development. On a global scale informal settlements are a significant problem especially in third world countries housing the world's disadvantaged (May, Budiender, Mokate, Rogerson & Stavrou, 1998).

The majority of South Africa's poor are African, as are the majority of informal settlement dwellers. In 1994, approximately 1,06 million households comprising 7.7 million people lived in informal settlements (Statistics South Africa, 1997). Coupled to this, an estimated 720 000 serviced sites that were provided by provincial

legislatures under the previous government required upgrading and 450 000 people lived in various, often inappropriate, forms of hostel accommodation (Du Plessis & Landman, 2002).

2.3.1 Impacts

The above statements bear a sad testimony to the experiences of many residents in South Africa who have had to struggle to acquire services like water, electricity, toilets, schools, recreational facilities, rubbish collection etc. As water supply levels and population density increase, the impervious surfaces and wastewater produced per unit, increase beyond the drainage capacity of the land. This results in wastewater run-off that may be exacerbated by a shallow groundwater table or impermeable soil (Du Plessis & Landman, 2002).

Historically, grey-water has been defined as wastewater that does not contain significant amounts of faecal pollution (i.e. not sewage discharges). Typically, this consists of water discharged from baths, showers and sinks. (Water from flush toilets is not grey-water, as it contains faecal matter). When considering grey-water in terms of densely populated and more specifically informal settlements, however, this may include other pollutants such as sewage, animal and human faeces, motor oil, paraffin and blood and stomach contents from slaughter areas

In these areas, wastewater is full of micro-organisms, and can introduce diarrhoeal diseases such as gastroenteritis (which is of an endemic persistent nature and is always around), and cholera (which is of a cyclic or epidemic nature) (Saff, 1996). The wastewater generated in densely populated informal settlements is not only of concern to the health and well-being of the community, but also has an impact on the water resources into which this diffuse pollution flows. Anthropogenic nutrient enrichment of water resources is evident in highly populated and developed areas where poor maintenance of sewage systems and disposal of wastewater practices contribute to elevated loads of nutrients into receiving natural water systems. The nutrients promote the growth of biological material in receiving systems, causing a

wide array of water quality problems. South Africa itself has some of the most highly enriched surface waters in the world. This enrichment leads to algal blooms, which can be toxic to animals and people, and leads to an increased cost in the purification of water for potable use.

BKS Engineering and DWAF did a case study relating to impacts in 1995 where the water quality of the Jukskei and Klip River was evaluated in terms of all its users and according to each sub-catchment. The following is a summary of the analysis (Du Plessis & Landman, 2002):

Current status of the Jukskei catchment. Surface water running through the Eastern Metropolitan Local Council area, especially in the vicinity of Alexandra, shows evidence of sewage pollution: high *E. coli*; low pH values; high electrical conductivity; varied ammonia and COD levels; and varied phosphate, sulphate and nitrate levels.

Current status of the Klip River Catchment: The water quality of rivers in Greater Soweto (Southern Metropolitan Local Council) shows evidence of sewage pollution: high *E. coli*; low pH values; high electrical conductivity; contamination from raw sewage (as a result of sewer blockages which occur from time to time). High *E. coli*, low pH, high EC, phosphates, ammonia and COD show probable blocked sewers in the vicinity.

2.3.2 Remediation

Kliptown, part of greater Soweto, is a densely populated area with a number of informal settlements, including the Freedom Charter informal settlement which has a density of >70 houses/hectare mostly informal shacks. The most visible pollution problem has been the streams of wastewater running through the settlement and pooling in depressions along the banks of the Klip River. Water supply is from standpipes, which also serve as washing up points. This means that there has been a constant flow of wastewater.

In 2000, DWAF used a Structured Facilitation Approach to detail problems and identify solutions in 13 pilot studies around the country where waste was having an impact on water quality. Kliptown was one of these pilots. A community reference group was established to facilitate the project from the community side, along with DWAF and the Johannesburg City Council. A problem tree was drawn up for the wastewater (DWAF, 2002).

Analyses of the wastewater indicated high faecal contamination, as well as a high nutrient content. Taps were often left running to rinse clothing, further exacerbating the problem. There was no drainage system, and few gardens on which to dispose of the wastewater generated. The wastewater streams running through the settlement were playgrounds for animals and children alike, leading to high incidences of gastroenteritis.

To alleviate this problem and with Danced funding and DWAF support; the community laid drainage pipes and constructed drainage facilities around the standpipes, as well as at other points along the line. The system drains towards the river where the intention is to connect it to a main sewer line. After completion of the project monitoring continued and indicated an improvement of water quality. Monitoring of the river up and downstream of the settlement (by both DWAF and the community from 2000 onwards) indicated decreased faecal contamination, as well as nutrient loads entering the resource. Monitoring of gastroenteritis cases at the clinic indicated decreased illnesses in the children from the community. Issues of basic services like water, health and shelter are also human rights issues and are guaranteed by the Constitution of the country. However, the pattern and speed that land invasion took following the relaxation of influx control laws make it almost impossible for any speedy amelioration of the problems.

A case study concerning informal settlements stems from India. Rapid urbanisation has generated the problem of informal settlements in almost every city in India according to the Institute of Remote Sensing (NRSA). A rural population migrates

to the city in search of employment and out of sheer necessity, has no alternative but to settle in existent slum areas or to search for new sites of least resistance in which to establish shelter (Sur, 2003). Dehradun, capital of the newly formed state of Uttaranchal in India, is strategically situated in the Himalayan foothills, with undulating topography and landform and drained by two major seasonal rivers, the Rispana and the Bindal Rao. The problem of informal settlements increased here after Dehradun became the capital in 2000, when new job opportunities presented themselves in both the formal and informal sector (Sur, 2003)

Sur (2003) suggested some other remediation methods:

- High algal growth potential will lead to eutrophication of dams and will kill aquatic ecosystems by using up all oxygen. High phosphate levels must be treated, sewers must be cleaned, and better sanitation provided.
- Wet on-site or off-site sewer sanitation systems are adequate for wastewater drainage. However, the applicability of the former is restricted as densities increase (10-40 units/hectare).
- Soak-aways should be constructed at public water supply points as well as where households have yard connections and dry on-site sanitation systems (<10 unit/hectare).
- Off-site wastewater drainage (i.e. sanitation) is required where the density of a settlement increases, and where local groundwater or soil conditions reduce local drainage capacity (>40 units/hectare).
- Rural water supply and sanitation should concern rural water supply, distribution systems, on-site sanitation, water and hygiene education, and catchments protection.
- Care should be taken to develop ecologically sensitive areas and other incidental spaces simultaneously with development of residential areas.
- Attempts should be made to regulate rapid urbanisation of land along rivers. Land lying along natural drainage channels should be protected and properly developed to maintain and improve water quality.

2.4 Sewage works

Sewage treatment, or domestic wastewater treatment, is the process of removing contaminants from wastewater, both run-off (effluents) and domestic. It includes physical, chemical and biological processes to remove physical, chemical and biological contaminants. Its objective is to produce a waste stream (or treated effluent) and a solid waste or sludge suitable for discharge or reuse back into the environment. This material is often inadvertently contaminated with many toxic organic and inorganic compounds (Greenberg *et al.*, 1998).

2.4.1 Impacts

Residences, institutions, hospitals, and commercial and industrial establishments create sewage. It can be treated close to where it is created (in septic tanks, biofilters or aerobic treatment systems), or collected and transported via a network of pipes and pump stations to a municipal treatment plant. Sewage collection and treatment is typically subject to local, state and federal regulations and standards (regulation and controls). Typically, sewage treatment involves three stages, called primary, secondary and tertiary treatment. First, the solids are separated from the wastewater stream then dissolved biological matter is progressively converted into a solid mass by using indigenous, water-borne micro-organisms. Finally, the biological solids are neutralised then disposed of or re-used, and the treated water may be disinfected chemically or physically (for example by lagoons and micro-filtration). The final effluent can be discharged into a stream, river, bay, lagoon or wetland, or it can be used for the irrigation of a golf course, green way or park. If it is sufficiently clean, it can also be used for groundwater recharge. Figure 2.3 is an illustration of a sewage plant.

In many developing countries the bulk of domestic and industrial wastewater is discharged without any treatment or after primary treatment only. In Latin America about 15% of collected wastewater passes through treatment plants (with varying levels of actual treatment). In Venezuela, a below average country in South

America with respect to wastewater treatment, 97% of the country's sewage is discharged raw into the environment. In a relatively developed Middle Eastern country such as Iran, Tehran's majority of the population has totally untreated sewage injected to the city's groundwater. Most of sub-Saharan Africa is without wastewater treatment.

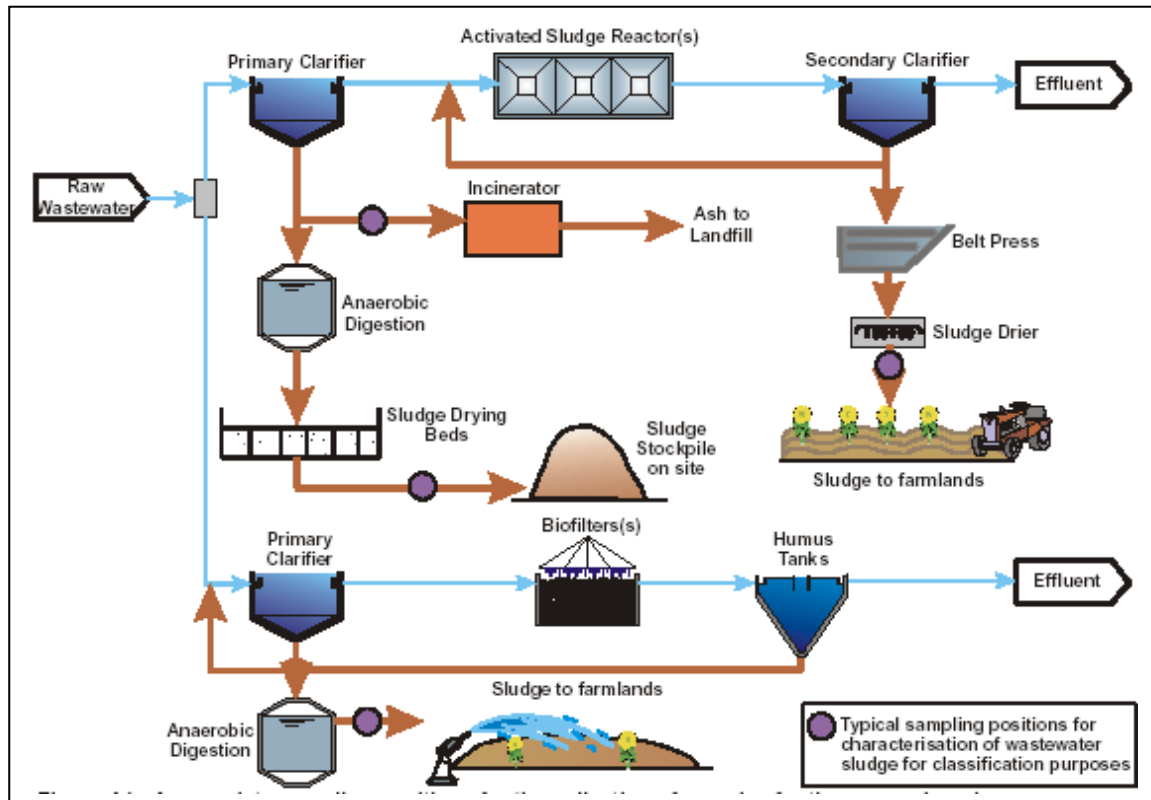

Figure 2.3 ILLUSTRATION OF A SEWAGE PLANT (WHO, 1993)

In many developing countries the bulk of domestic and industrial wastewater is discharged without any treatment or after primary treatment only. In Latin America about 15% of collected wastewater passes through treatment plants (with varying levels of actual treatment). In Venezuela, a below average country in South America with respect to wastewater treatment, 97% of the country's sewage is discharged raw into the environment. In a relatively developed Middle Eastern country such as Iran, Tehran's majority of the population has totally untreated

sewage injected to the city's groundwater. Most of sub-Saharan Africa is without wastewater treatment.

Water utilities in developing countries are chronically under funded because of low water tariffs, the inexistence of sanitation tariffs in many cases, low billing efficiency (i.e. many users that are billed do not pay) and poor operational efficiency (i.e. there are overly high levels of staff, there are high physical losses, and many users have illegal connections and are thus not being billed). Developing countries as diverse as Egypt, Algeria, China or Colombia have invested substantial sums in wastewater treatment without achieving a significant impact in terms of environmental improvement. Even if wastewater treatment plants are operating properly, it can be argued that the environmental impact is limited in cases where the assimilative capacity of the receiving waters (ocean with strong currents or large rivers) is high, as it is often the case (Tchobanoglous, Burton & Stensel, 2003).

2.4.1.1 Contaminants

Without the proper treatment wastewater may contain high levels of the nutrients, nitrogen, phosphorus and Faecal coliform. Nitrate (NO_3) is used to represent the nutrient status of water resources. High levels are generally related to influences from agricultural and urban activities, for example sewage effluent discharges. Phosphate (PO_4) is also used to represent the nutrient status of water resources. High levels are generally related to urban activities such as the use of detergents. Faecal coliform levels are used to indicate levels of microbiological contamination, which poses possible risks to health and recreational activities. Ingestion of or contact with water contaminated with faecal coliforms results in dysentery, diarrhoea and skin infections (Dias & Bhat, 1965).

Excessive release of wastewater from ineffective sewage plants to the environment can lead to a build up of nutrients, called eutrophication, which can in turn encourage the overgrowth of weeds, algae, and cyanobacteria (blue-green algae).

This may cause an algal bloom, a rapid growth in the population of algae. The algae numbers are unsustainable and eventually most of them die. The decomposition of the algae by bacteria uses up so much of the oxygen in the water that most or all of the animals die, which creates more organic matter for the bacteria to decompose. In addition to causing deoxygenating, some algal species produce toxins that contaminate drinking water supplies (Rodhe, 1969).

Dissolved and organic constituents of wastewater require the presence of a certain quantity of oxygen in the water for their biochemical breakdown, where this occurs aerobically. This is determined in the same way as in the wastewaters themselves and is hence called biochemical oxygen demand. Where the oxygen content or the oxygen uptake capacity of a receiving body of water is not sufficient for the biochemical oxidation of the organic substances fed into it, their further breakdown proceeds anaerobically. This results in the bacterial reduction of nitrates, sulphates, oxygen-containing organic compounds etc. to form carbon dioxide, hydrogen sulphide or sulphides, ammonia, nitrogen and other decomposition products.

South African pollution of water resources occurs in the form of point-source releases (for example discharges from sewage treatment works). Currently, DWAF is developing a Water Management System (WMS) database, which collects information on volumes of point source discharges entering water resources. An example, of how increased urban development is increasing pollution loads, can be seen in the overloading and lack of maintenance of sewage systems, most of which are operated by service providers such as the municipalities, East Rand Water Care Company (ERWAT) and Magalies Water. Data provided by Johannesburg Water indicate that there is a small increase in the volumes of sewage effluent being discharged to surface waters and greater increases are expected for works located on the edges of urban development zones. In more rural areas, sewage treatment is handled by privately owned package treatment works or tank systems (DWAF, 1999b).

The quality of surface water is represented spatially in Figure 2.4 by comparing the results of water quality monitoring for TDS, phosphate and nitrate (90th percentile value for the period 1999 to 2003) in Gauteng for different rivers to DWAF's water quality guidelines for consumptive domestic use in the case of TDS and nitrate (DWAF, 1999b).

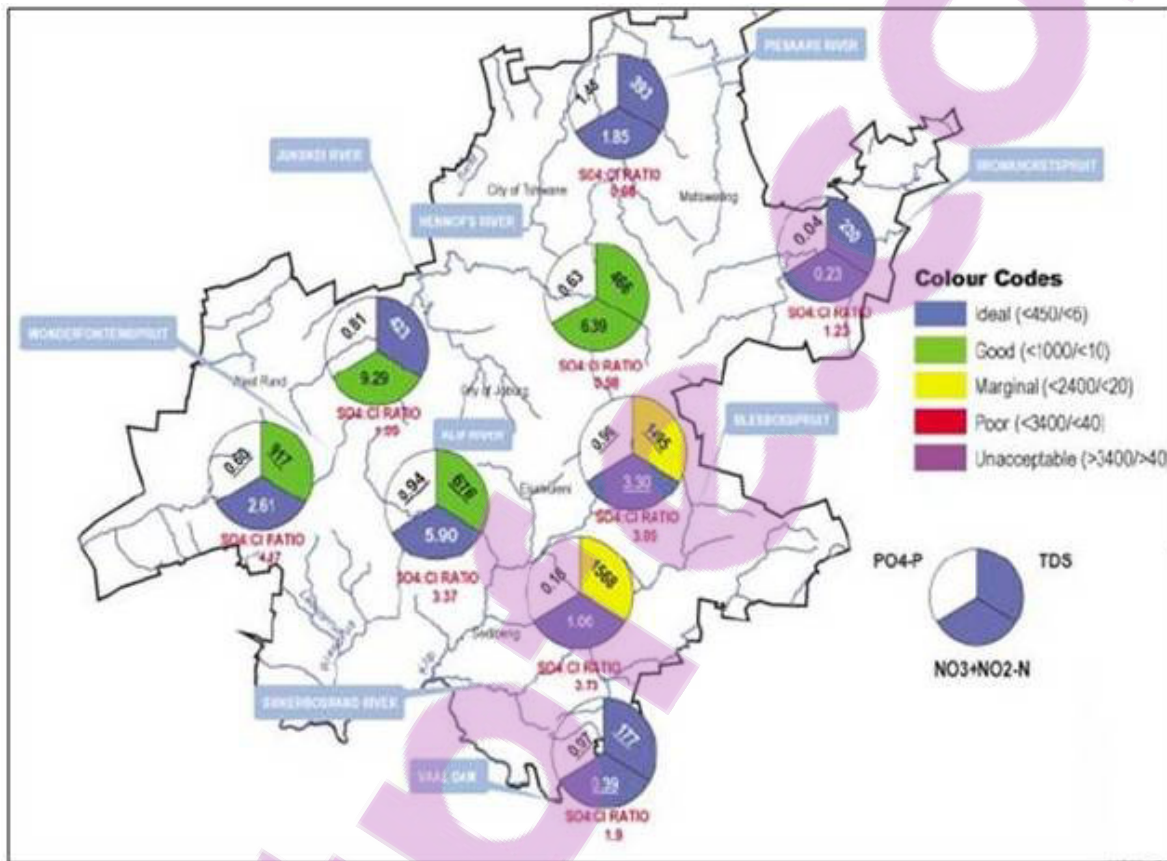

Figure 2.4 RESULTS OF WATER QUALITY (DWAF, 1999a)

There is no domestic guideline for phosphate. Sulphate/chloride ratios are also presented in red in this figure. Catchment management forums have been formed in some of the water management areas (WMA) and each catchment management forum has, or is in the process of developing, specific in-stream water quality guidelines. Table 2.2 shows the ideal range of water quality guidelines for TDS, NO₃, PO₄ and faecal coliforms for some of the rivers found in Gauteng (note that

not all the catchments have water quality guidelines yet). Some of the guidelines set by the catchment management forums are more stringent than DWAF's guidelines for domestic use (DWAF, 2002). Table 2.2 shows the ideal range of water quality guidelines for EC, TDS, NO₃, PO₄ and faecal coliforms (DWAF, 1999b).

Table 2.2 IDEAL RANGE OF WATER QUALITY GUIDELINES

	EC (mS/m)	TDS (mg/l)	NO ₃ +NO ₂ (mg/l)	NO ₃ (mg/l)	PO ₄ (mg/l)	Faecal coliforms (counts/100ml)
DWAF National domestic water quality guidelines	70	450	6	-	1.00	<1
Klip River	<80	-	-	<2.0	<0.20	<1000
Blesbokspruit & Suikerbosrand	<45	-	-	<0.5	<0.20	<126
Vaal Barrage	<30	-	-	<1.0	<0.25	<131
Vaal Dam	<10	-	-	<0.1	<0.05	<10
Wonderfonteinspruit	40	280	5	-	0.10	-

Although not shown in Figure 2.4, the available data shows that poor levels of faecal coliform are evident in the Pienaar's, Hennops, Klip River, Suikerbosrand rivers and the Vaal Dam. Faecal pollution of these rivers has historically been a problem (DWAF, 1999a). Currently, the faecal coliform levels are unacceptable in terms of DWAF's water quality guidelines for consumptive domestic use (should be less than 1 count per 100 ml) (DWAF, 1999b). Due to data limitations for groundwater quality, it is difficult to indicate the current status of groundwater in the province and whether the quality is deteriorating with time.

2.4.1.2 Groundwater contamination

The water quality of seven sites on the upper reaches of the River Kennet round the market town of Marlborough is described and related to the introduction of

phosphorus treatment of effluent from Marlborough sewage treatment works (STW). The River Kennet is mainly groundwater-fed from a Cretaceous chalk aquifer and hence the river water is calcium- and bicarbonate-bearing and has a relatively constant composition of many major water quality determinants. The concentrations of soluble reactive phosphorus (SRP), total phosphorus (TP) and boron increased markedly just downstream of the sewage works as a result of this point source input. These concentrations slowly declined further downstream as additional groundwater inputs dilute the effluent further.

The introduction of chemical treatment of sewage effluent for phosphorus reduction at Marlborough STW resulted in a marked decrease in within-river SRP and TP concentrations to levels approximately the same as those upstream of the STW. A comparison of SRP and boron concentrations reveals a reduction in in-stream SRP concentrations by approximately 75% following effluent treatment (Edmunds, 1987).

In terms of within-river processes controlling in-stream phosphorus concentrations, previous studies have indicated that one potentially important mechanism within calcium bicarbonate bearing rivers may be related to co-precipitation of phosphorus with calcium carbonate (calcite). The present study shows that the waters are over saturated with respect to calcium carbonate, that no equilibrium conditions exist and that phosphorus removal has led to undetectable changes in calcium carbonate over saturation. Hence, it is concluded that the primary changes in phosphorus levels within the river is directly associated with changing point source contributions from the STW and physical dilution within the river.

However, (1) the results relate to only the first year of study and subsequent differences may become apparent; and (2) reactions between the water column and plant and bottom sediment interfaces may be important in regulating phosphorus fluxes within the river.

2.4.2 Remediation

2.4.2.1 Nitrogen removal

The removal of nitrogen is effected through the biological oxidation of nitrogen from ammonia (nitrification) to nitrate, followed by denitrification, the reduction of nitrate to nitrogen gas. Nitrogen gas is released to the atmosphere and thus removed from the water. Nitrification itself is a two-step aerobic process, each step facilitated by a different type of bacteria. The oxidation of ammonia (NH_3) to nitrite (NO_2^-) is most often facilitated by *Nitrosomonas spp.* (nitroso = ammonium). Nitrite oxidation to nitrate (NO_3^-), though traditionally believed to be facilitated by *Nitrobacter spp.* (nitro = nitrite), is now known to be facilitated in the environment almost exclusively by *Nitrospira spp.*

Denitrification requires anoxic conditions to encourage the appropriate biological communities to form. It is facilitated by a wide diversity of bacteria. Sand filters, lagooning and reed beds can all be used to reduce nitrogen, but the activated sludge process (if designed well) can do the job the most easily. Since denitrification is the reduction of nitrate to denitrogen gas, an electron donor is needed. This can be, depending on the wastewater, organic matter (from faeces), sulphide, or an added donor like methanol. Sometimes the conversion of toxic ammonia to nitrate alone is referred to as tertiary treatment (Atlas & Barthas, 1997).

2.4.2.2 Phosphorus removal

Phosphorus can be removed biologically in a process called enhanced biological phosphorus removal. In this process, specific bacteria called polyphosphate-accumulating organisms are selectively enriched and accumulate large quantities of phosphorus within their cells (up to 20% of their mass). When the biomass enriched in these bacteria is separated from the treated water, these bio-solids have a high fertilizer value.

Phosphorus removal can also be achieved by chemical precipitation, usually with salts of iron (e.g. ferric chloride) or aluminium (e.g. alum). The resulting chemical sludge is difficult to handle and the added chemicals can be expensive. Despite this, chemical phosphorus removal requires significantly smaller equipment footprint than biological removal, is easier to operate and can be more reliable in areas that have wastewater compositions that make biological phosphorus removal difficult (Watson, Reed, Kadlec, Knight & Whitehouse, 2002).

2.4.2.3 Nutrient removal

The purpose of disinfection in the treatment of wastewater is to substantially reduce the number of micro-organisms in the water to be discharged back into the environment. Chloramine, which is used for drinking water, is not used in wastewater treatment because of its persistence. Chlorination remains the most common form of wastewater disinfection in North America due to its low cost and long-term history of effectiveness. One disadvantage is that chlorination of residual organic material can generate chlorinated-organic compounds that may be carcinogenic or harmful to the environment. Residual chlorine or chloramines may also be capable of chlorinating organic material in the natural aquatic environment. Furthermore, because residual chlorine is toxic to aquatic species, the treated effluent must also be chemically dechlorinated, adding to the complexity and cost of treatment.

Ultraviolet (UV) light can be used instead of chlorine, iodine, or other chemicals. Because no chemicals are used, the treated water has no adverse effect on organisms that later consume it, as may be the case with other methods. UV radiation causes damage to the genetic structure of bacteria, viruses, and other pathogens, making them incapable of reproduction. The key disadvantages of UV disinfection are the need for frequent lamp maintenance and replacement, and the need for a highly treated effluent to ensure that the target micro-organisms are not shielded from the UV radiation (i.e. any solids present in the treated effluent may protect micro-organisms from the UV light) (Watson *et al.*, 2000).

In the United Kingdom, light is becoming the most common means of disinfection because of the concerns about the impacts of chlorine in chlorinating residual organics in the wastewater and in chlorinating organics in the receiving water. Edmonton (Alberta, Canada) also uses UV light for its water treatment. Ozone O_3 is generated by passing oxygen (O_2) through a high voltage potential resulting in a third oxygen atom becoming attached and forming O_3 . Ozone is very unstable and reactive and oxidises most organic material with which it comes in contact thereby destroying many pathogenic micro-organisms. Ozone is considered to be safer than chlorine because, unlike chlorine, which has to be stored on site (highly poisonous in the event of an accidental release), ozone is generated onsite as needed. Ozonation also produces fewer disinfection by-products than chlorination. A disadvantage of ozone disinfection is the high cost of the ozone generation equipment and the requirements for highly skilled operators (Water Quality Association, 2000).

2.4.2.4 *Package plants and batch reactors*

In order to use less space, treat difficult waste, deal with intermittent flow or achieve higher environmental standards, a number of designs of hybrid treatment plants have been produced. Such plants often combine all or at least two stages of the three main treatment stages into one combined stage.

In the UK, where a large number of sewage treatment plants serve small populations, package plants are a viable alternative to building discrete structures for each process stage. One type of system that combines secondary treatment and settlement is the sequencing batch reactor (SBR). Typically, activated sludge is mixed with raw incoming sewage and aerated. The resultant mixture is then allowed to settle producing a high quality effluent. The settled sludge is run off and re-aerated before a proportion is returned to the head of the works. SBR plants are now being deployed in many parts of the world including North Liberty, Iowa, and Llanasa, North Wales.

The disadvantage of such processes is that precise control of timing, mixing and aeration is required. This precision is usually achieved by computer controls linked to many sensors in the plant. Such a complex, fragile system is unsuited to places where such controls may be unreliable, or poorly maintained, or where the power supply may be intermittent. Package plants may be referred to as high charged or low charged. This refers to the way the biological load is processed.

In high charged systems, the biological stage is presented with a high organic load and the combined flocculant and organic material is then oxygenated for a few hours before being charged again with a new load. In the low charged system the biological stage contains a low organic load and is combined with flocculant for a relatively long time.

2.4.2.5 *Constructed wetlands*

Constructed wetlands include engineered reed-beds and a range of similar methodologies, all of which provide a high degree of aerobic biological improvement and can often be used instead of secondary treatment for small communities (also see phytoremediation). One example is a small reed-bed used to clean the drainage from the elephants' enclosure at Chester Zoo in England.

2.5 Tailings dam

2.5.1 Impacts

Mineral processing of hard rock metal ores (e.g. Au, Cu, Pb, Zn, U) and industrial mineral deposits (e.g. phosphate, bauxite) involves size reduction and separation of the individual minerals. In the first stage of mineral processing, blocks of hard rock ore up to a meter across are reduced to only a few millimetres or even microns in diameter. First crushing and then grinding and milling the ore achieve this. Crushing is a dry process; grinding involves the abrasion of the particles that are generally suspended in water. The aim of the size reduction is to break down the ore so that the ore minerals are liberated from gangue phases. In the second

stage of mineral processing, the ore minerals are separated from the gangue minerals.

This stage may include several methods, which use the different gravimetric, magnetic, electrical or surface properties of ore and gangue phases. Coal differs from hard rock ore and industrial mineral deposits, as it does not pass through a mill. Instead, the coal is washed, and coal washeries produce fine-grained slurries that are discarded as wastes in suitable repositories. Consequently, the end products of ore or industrial mineral processing and coal washing are the same: (a) a concentrate of the sought-after commodity; and (b) a quantity of residue wastes known as “tailings”.

Tailings typically are produced in the form of a particulate suspension, that is, fine-grained sediment-water slurry. The tailings dominantly consist of the ground-up gangue from which most of the valuable mineral(s) or coal has been removed. The solids are unwanted minerals such as silicates, oxides, hydroxides, carbonates, and sulphides. Recoveries of valuable minerals are never 100%, and tailings always contain small amounts of the valuable mineral or coal (Winde, Wade & Van der Walt, 2004)

Historically, tailings were routinely discharged directly into the nearest surface water course (Vick, 1990). In some parts of the world this is still practiced today, particularly in areas of high rainfall and steep and unstable terrain. The Ok Tedi mine in Papua New Guinea and the Grasberg mine in Indonesia are just two examples of large mining operations that dispose of their tailings and waste rock directly into the local water course. This type of storage method creates vast environmental liabilities and costs associated with remediation and reclamation (Jakubick & McKenna, 2003).

Plugging of irrigation ditches and contamination of downstream areas were becoming more common creating conflicts between land and water use,

particularly where agriculture interests existed. By about 1930, a complete cessation to this type of tailings disposal was enforced in the western world creating the first benchmark regulations on mine waste management. It should be only a matter of time before mines like Ok Tedi and Grasberg, who still dispose of their tailings uncontrollably, are eventually restrained from doing so by regulations (Jakubick & McKenna, 2003).

Gold mining in South Africa resulted in vast volumes of tailings, which have been deposited in impoundments. Poor management of most of the tailings dams resulted in the escape of seepage, adversely affecting soils and water quality. Some tailings dams have been partially or completely reclaimed leaving contaminated footprints. These zones pose a serious threat to the underlying dolomitic aquifers.

The footprints of seven selected sites situated near Johannesburg have been investigated. It was found that the topsoil is highly acidified and only a minor portion of contaminants is bio-available. However, phytotoxic contaminants such as Co, Ni and Zn could complicate rehabilitation measures as they limit the soil function. In addition, soil samples contain trace element concentrations, which often exceed background concentrations in soils. As a result, the depletion of buffer minerals and the subsequent acidification could result in the long-term remobilisation of large quantities of contaminants into the groundwater. Soil management measures such as liming and barriers are required to prevent the contaminant migration from the topsoil into the subsoil and groundwater, as well as to provide suitable recultivation conditions to enable future land use (DME, 2000).

The ultimate purpose of a tailings impoundment is to contain tailings in a cost-effective manner that provides for long-term stability of the impoundment and long-term protection of the environment. Water control and management are perhaps the most critical components of tailings impoundment designs and operation. The failure modes discussed previously are all related to water in the impoundment

and/or the embankment. Similarly, the environmental impacts of tailings and impoundments are related to water control and management, either directly, as in the cases of ground or surface water contamination, or indirectly, as in the case of airborne transport of dry tailings. Water has been discussed in the previous section in terms of stability; in this section, it is discussed in terms of environmental performance (MCMPR & NCA, 2003).

Most recently, environmental issues have come to the forefront of tailings impoundment design, with special concerns over the quality of effluent and seepage from tailings impoundments, both to ground water and surface water. This concern has led to both an increase in treatment of especially toxic tailings effluent prior to discharge and more effort toward total containment of the tailings water within the impoundment.

The latter effort (i.e., containment) is a challenge that has not been overcome: some methods of **seepage control** are more effective than others; however, 'Zero discharge,' even with the use of impoundment liners, remains an elusive goal. Infiltration rates are generally low because of the small particle size and low permeabilities in the tailings. Infiltration rates are a function of a soil's moisture content, capillary pressure, unsaturated hydraulic conductivity, and the distance below the surface. There is no run-off or ponding when the infiltration rate is less than the saturated hydraulic conductivity. Run-off or ponding occurs when the infiltration rate is larger than the infiltration capacity and the saturated hydraulic conductivity (Vick, 1990).

The crucial two elements that have to be contained are TDS and sulphates (Volpe & Kelly, 1985):

- **Total dissolved solids (TDS)** are used to indicate the salinity of surface water resources. TDS levels indicate the suitability of water for various uses such as domestic consumption, agriculture or industrial activities. High levels are generally related to leaks from these tailing dams.

- **Sulphate/chloride ratio** is used to indicate influence of mining on increased salinity (for surface waters only).

2.5.2 Remediation

Historically, controlled seepage through embankments has been encouraged to lower the phreatic surface and increase stability. Evaluation of the volume and direction of seepage is conducted by using hydraulic principles similar to those used in embankment design. The same variables that are used during the design phase to predict the phreatic surface can be used to estimate the volume of seepage flow. Similarly, variables, such as permeability of the embankment and foundation might affect the phreatic surface also affect seepage rates and volumes. However, more exact and extensive data may be required than for the calculation of pore pressures for analysis. Flow characteristics of tailings impoundments, their foundations, and underlying soil can be viewed as an inter-related system, with both saturated and unsaturated components (Mittal & Morgenstern, 1976).

Seepage evaluation can require information on: (1) components from geologic, hydrologic, and hydrogeologic studies; and (2) physical and chemical characterisations of surface water inflows, seepage, and tailings. Geologic factors affecting seepage are fractured rock, clay lenses, and uplifted geologic formations with large differences in permeability. Hydrologic data is affected by rainfall intensity, soil type, and surface conditions. This data can be used to calculate infiltration rates. Hydrogeologic studies can determine: (1) the critical path and degree of anisotropy of the ground water; (2) the boundary conditions for ground water flow evaluations; (3) the moisture content, permeability, and porosity of the tailings and underlying soil; (4) the thickness of the unsaturated zone and capillary fringe; and (5) the storage capacity, hydraulic conductivity, and transmissivity of the tailings and underlying aquifer. Flow nets and more complex models of seepage flow can be prepared. A mass balanced approach can also be used (Ferguson, Hutchinson & Schiffman, 1985).

The chemical composition of tailings seepage is important in determining potential environmental impacts. Factors include waste characteristics such as mineralogy of the host rock and milling methods used to produce the tailings, and the interaction of the tailings seepage with the liner (if any) and the subsurface (Vick, 1990).

Contaminant mobility can be increased by physical mining processes such as milling (a small grind results in increased surface area for leaching). Most mining companies manipulate the pH and use chelating agents to extract minerals from the ore. These same processes can be applied to the fate and transport of contaminants in tailings. While many heavy metals are hydrophobic with strong adsorption tendencies for soil, chemical reagents used in mining processes may be present in the tailings material. They are able to adsorb the metals, making them mobile in leachate or surface waters. Contaminated water may be formed from downward migration of impoundment constituents or ground water movement through tailings. Most contaminant transport in ground water systems is from the advection (fluid movement and mixing) of contaminants. Factors affecting the rate of advection include ground water/leachate velocity, chelation, pH, and partition coefficient values.

The geochemistry of the aquifer, physicochemical properties of the tailings and seepage will determine the buffering capacity of the soil, types of chemical reactions (precipitation or neutralisation) and the rate of adsorption and ion exchange. A related problem is the production of acid by oxidation of thiosalts, which is a problem for some metal mines in eastern Canada. The bacterial culprit is *Thiobacillus thiooxidans*. Thiosalts may be removed from the mill effluent by biological treatments (Parsons, 1981). According to Vick (1990), neutralisation, oxidation/reduction, precipitation adsorption, ion exchange, and biological reactions play a major role in the chemical composition of tailings seepage. These are many of the same reactions used in milling operations to free the desired mineral.

Seepage quality can be modelled using complex geochemical methods (Vick, 1990; Ritcey, 1989).

It is only in the last two decades that lining of tailings dams became compulsory, therefore the best mitigation method is to contain the seepage on site and treat or reuse it. Some containment methods used today are discussed.

2.5.2.1 Embankment barriers

Embankment barriers are installed below the impoundment and include cut-off trenches, slurry walls and grout curtains. An impervious layer of fill is generally required between them and the tailings. Barriers are installed underneath the upstream portion of a downstream embankment and the central portion of centre-line embankments; they are not compatible with upstream embankments. A good water-quality monitoring programme is needed when using embankment barriers to ensure that they are completely effective in intercepting flows and also that seepage is not moving downward and contaminating the ground water.

Cut-off trenches, usually 5 to 20 feet in depth, are the most widely used type of embankment barrier for tailings dams, especially in areas with large volumes of natural clays. Dewatering may be necessary during the installation of cut-off trenches when they are installed below the ground water table.

Slurry walls are narrow trenches that are best suited to sites with a level topography and containing saturated or fine-grained soils. They are not compatible with fractured bedrock systems. Excavating a trench to a zone of low permeability material and filling the trench with soil/bentonite slurry, which is then allowed to set to a consistency of clay, install the slurry walls. Depths average 40 feet and permeabilities obtained can be as low as 10 cm/sec. Grout curtains use cement, silicate materials, or acrylic resins as a barrier to seepage movement. They are limited to sites with coarse-grained material (medium sands to gravel or fractured

rock with continuous open joints) and can extend to depths of more than 100 feet. Permeabilities obtained can be as low as 10 cm/sec.

However, leaks can occur through curtain joints or by subsequent corrosion of the curtain (Vick, 1990). Rather than simply intercepting and containing seepage flows, barriers may have gravel (or other pervious material appropriately filtered) drains immediately upgradient to allow seepage to be removed or directed to embankment underdrains. Barriers and seepage collection systems also may be used downgradient of embankments to prevent further environmental releases.

Pumpback systems consist of seepage ponds and/or seepage collection wells installed downgradient of the impoundment that are outfitted with pumps that send seepage back to the impoundment or for use as process water. Current practices include the use of toe ponds or seepage ponds to collect seepage. In some cases, underdrains or toe drains are designed to flow into the seepage pond. In other cases, however, these systems are installed after construction of the impoundment as a remedial action to collect unanticipated seepage. These units may be used in conjunction with slurry walls, cut-off trenches or grout curtains to minimise downgradient seepage. Depending on effluent quality, the operation of the pump-back system may continue indefinitely (Van Zyl, Hutchison & Kiel, 1988).

2.5.2.2 *Tailings water treatment*

Tailings ponds can be effective in clarifying water prior to discharge. Many factors influence the effectiveness of the pond to provide sufficient retention time to permit the very fine fractions to settle before reaching the point of effluent discharge or time for unstable contaminants to degrade. Factors affecting settling time are the size of grind, the tendency to slime (particularly with clay type minerals), the pH of the water, wave action, depth of the water, and distance between the tailings discharge and the effluent discharge. Although settling velocities of various types and grain sizes of solids can be determined both theoretically and experimentally, many factors influence effectiveness of the decant pool as a treatment device.

In 1992, the South Dakota Department of Environment and Natural Resources (DENR) identified environmental problems associated with reactive sulphide rocks at a valley-fill waste depository at LAC Minerals' Richmond Hill gold mine. This led to a shut down of the mine, a significant increase in the reclamation surety bond from \$1.2 million to \$10.7 million, a settlement of \$489,000 for permit and water quality standard violations, and the development of an seepage reclamation plan that is currently in the final stages of completion and exhibiting impressive results (Duex, 1994).

Other numerous abandoned mine reclamation and seepage containment projects have been conducted by active mine operators in the Black Hills on a voluntary basis. These efforts have resulted in a net improvement to the environment while lowering the environmental liability posed by the abandoned mine sites. One of the more notable reclamation projects was conducted by Brohm Mining Corporation, which operates an active heap leach mine. To counter the immediate problem of contaminated surface discharge down Spruce Gulch into perennial Squaw Creek in the early spring of 1992, a series of treatment ponds were constructed at the toe of the waste dump to chemically treat the dump effluent. Contaminated discharge was first treated with an anoxic limestone drain that proved ineffective. The limestone became armoured with iron hydroxide, which rendered it ineffective in neutralisation. Below the treatment ponds, a retention pond designed to accommodate the 10-year, 24-hour storm event was constructed. Treatment was first accomplished by the addition of soda ash, and later the additive was changed to caustic soda. The resulting metal hydroxide sludges can be periodically removed (Pirner, 1990).

Partially treated water in the retention pond is then pumped to Richmond Hill's large, lined storm-water pond located at the process facility that has a capacity to accommodate about 80 million gallons. The partially treated water undergoes significant dilution in the storm-water pond and is contained and made available for further treatment in a water treatment plant before discharge.

Other short-term mitigation actions include the following. The sulphide ore stockpile was removed from the waste dump and placed on the leach pads where resulting contamination could be contained. Diversion ditches were constructed around the Spruce Gulch waste dump to direct clean surface run-off from above the dump, around it. A certain amount of lime, limestone and alkaline fly ash was added to the waste dump at key locations for further neutralisation. A semi-sealant material called Entac was sprayed on the waste dump in 1992 in an attempt to minimise infiltration of precipitation. Migration of contaminated groundwater was addressed by constructing a cut-off trench in the shallow alluvium across the valley below the waste dump. The resulting water is collected and directed to the treatment ponds.

These treatment processes effectively remove metals and buffer pH. Sulphate and TDS are not effectively removed by base addition to the Spruce Gulch treatment ponds. Comparisons can be made of water quality data representing samples taken from the toe of the waste dump above the treatment ponds and samples taken from Spruce Gulch below the treatment system to determine the effectiveness of the control measures. The water quality data indicates that the combination of short-term control methods have proven to be quite successful at improving surface water quality below the waste dump (Pirner, 1990).

2.5.2.3 *Gilt Edge mine*

Numerous abandoned mine reclamation projects have been conducted by active mine operators in the Black Hills of South Dakota on a voluntary basis. These efforts have resulted in a net improvement to the environment while lowering the environmental liability posed by the abandoned mine sites.

One of the more notable reclamation projects was conducted by Brohm Mining Corporation, which operates an active heap leach mine in the northern Black Hills. Tailings from mining operations at Gilt Edge in the early 1900's were placed by the "old-timers" in the drainage of Strawberry Creek, a perennial stream in its middle and lower reach. The Gilt Edge tailings were situated on property controlled by

Brohm Mining, adjacent to one of the open pits associated with the active, permitted mine operation.

The relic tailings originally contained relatively high concentrations of sulphide minerals. As the tailings continued to erode, they produced severe acid mine drainage for many decades along Strawberry Creek. Bear Butte Creek, a perennial stream classified as a marginal fishery into which Strawberry Creek flows, was impacted by acid run-off for varying distances below the confluence, depending on the season and contaminant load. In the late 1980's a pH of 1.9 was recorded in Strawberry Creek immediately below the tailings pile. Static tests conducted on the relic tailings in 1993 showed that much of the sulphides had oxidised, leaving behind a significant amount of stored oxidation products (acidity and heavy metals) as a result of previous oxidation reactions (Durkin, 1994).

In the fall of 1993, Brohm Mining removed approximately 150,000 tons of reactive tailings from the upper reaches of Strawberry Creek. The tailings were thoroughly mixed with alkaline fly ash from a local coal-fired power plant at a rate that provides sufficient neutralising potential for contained sulphides. The amended tailings were placed in a "high and dry" disposal area in compacted, 12-inch lifts, graded to a maximum slope of 3H:1V, and capped with a low permeability cover. The fly ash was applied to the tailings in haul trucks and mixed again with bulldozers prior to compaction as it was spread out in the disposal area.

Water was added to the fly ash/tailings mixture, which allowed hydration reactions to occur. This resulted in achieving a pozzolanic (i.e. cementitious) behaviour in the mixture, effectively isolating the reactive tailings from air and water. This type of AMD abatement procedure can be much more cost effective than using portland cement grout to achieve the desired reduction in permeability. The tailings were amended with fly ash at a rate sufficient to ensure that the acid-neutralising potential to acid-generating potential (ANP:AGP) ratio is greater than or equal to 3:1. The fly ash exhibited an average neutralising potential of 467 tons/kiloton and

was added to the tailings at an approximate rate of 25 tons/kiloton of tailings (Durkin, 1994). This proportion was found to be sufficient to neutralise available acidity in the tailings and produce a net neutralisation potential of 20 tons/kiloton in the amended tailings. The tailings cleanup activities resulted in a significant improvement in water quality and aquatic habitat in Strawberry Creek.

2.6 Agricultural activity

United Nations' predictions of global population increase to the year 2025 require an expansion of food production of about 40-45%. Irrigation agriculture, which currently comprises 17% of all agricultural land yet produces 36% of the world's food, will be an essential component of any strategy to increase the global food supply. Currently 75% of irrigated land is located in developing countries.

2.6.1 Impacts

In addition to problems of waterlogging, desertification, salinisation, erosion, etc., that affect irrigated areas, the problem of downstream degradation of water quality by salts, agrochemicals and toxic leachates is a serious environmental problem. It is of relatively recent recognition that salinisation of water resources is a major and widespread phenomenon of possibly even greater concern to the sustainability of irrigation than is that of the salinisation of soils (Rhoades, 1993). Table 2.3 provides a summary on agricultural impacts on water quality.

Polluted water is a major cause of human disease, misery and death. According to the World Health Organisation (WHO), as many as 4 million children die every year as a result of diarrhoea caused by water-borne infection. The bacteria most commonly found in polluted water are coliforms excreted by humans. Surface run-off and consequently non-point source pollution contributes significantly to high level of pathogens in surface water bodies (Sagardoy, 1993).

Table 2.3 AGRICULTURAL IMPACTS ON WATER QUALITY (Rhoades, 1993)

Agricultural activity	IMPACTS	
	Surface water	Ground water
Tillage/ploughing	Sediment/turbidity: sediments carry phosphorus and pesticides adsorbed to sediment particles; siltation of river beds and loss of habitat, spawning ground, etc.	
Fertilizing	Run-off of nutrients , especially phosphorus , leading to eutrophication causing taste and odour in public water supply, excess algae growth leading to deoxygenation of water and fish kills.	Leaching of nitrate to groundwater; excessive levels are a threat to public health.
Manure spreading	Carried out as a fertilizer activity; spreading on frozen ground results in high levels of contamination of receiving waters by pathogens, metals, phosphorus and nitrogen leading to eutrophication and potential contamination.	Contamination of ground-water, especially by nitrogen
Pesticides	Run-off of pesticides leads to contamination of surface water and biota; dysfunction of ecological system in surface waters by loss of top predators due to growth inhibition and reproductive failure; public health impacts from eating contaminated fish. Pesticides are carried as dust by wind over very long distances and contaminate aquatic systems 1000s of miles away (e.g. tropical/subtropical pesticides found in Arctic mammals).	Some pesticides may leach into groundwater causing human health problems from contaminated wells.
Feedlots/animal corrals	Contamination of surface water with many pathogens (bacteria, viruses, etc.) leading to chronic public health problems. Also contamination by metals contained in urine and faeces.	Potential leaching of nitrogen, metals, etc. to groundwater.
Irrigation	Run-off of salts leading to salinisation of surface waters; run-off of fertilizers and pesticides to surface waters with ecological damage, bioaccumulation in edible fish species, etc. High levels of trace elements such as selenium can occur with serious ecological damage and potential human health impacts.	Enrichment of groundwater with salts , nutrients (especially nitrate).

Table 2.3 AGRICULTURAL IMPACTS ON WATER QUALITY (cont.)

Agricultural activity	IMPACTS	
	Surface water	Ground water
Clear cutting	Erosion of land, leading to high levels of turbidity in rivers, siltation of bottom habitat, etc. Disruption and change of hydrologic regime, often with loss of perennial streams; causes public health problems due to loss of potable water.	Disruption of hydrologic regime, often with increased surface run-off and decreased groundwater recharge; affects surface water by decreasing flow in dry periods and concentrating nutrients and contaminants in surface water.
Silviculture	Broad range of effects: pesticide run-off and contamination of surface water and fish; erosion and sedimentation problems.	
Aquaculture	Release of pesticides and high levels of nutrients to surface water and groundwater through feed and faeces, leading to serious eutrophication.	

Agricultural pollution is both a direct and indirect cause of human health impacts. The WHO reports that nitrogen levels in groundwater have grown in many parts of the world as a result of "intensification of farming practice". This phenomenon is well known in parts of Europe. Nitrate levels have grown in some countries to the point where more than 10% of the population is exposed to nitrate levels in drinking water that are above the 10 mg/l guideline. Although WHO finds no significant links between nitrate and nitrite and human cancers, the drinking water guideline is established to prevent methaemoglobinaemia to which infants are particularly susceptible (World Health Organization, 1993). Although the problem is poorly documented, nitrogen pollution of groundwater appears also to be a problem in developing countries. Lawrence (1986) reported nitrate concentrations approaching 40-45 mg N/l in irrigation wells that are located close to the intensively cultivated irrigated paddy fields. Figure 2.5 illustrates the variation in $\text{NO}_3\text{-N}$, which shows a peak in the maha (main) cropping season when rice growing is most intensive in Sri Lanka (Lawrence, 1986).

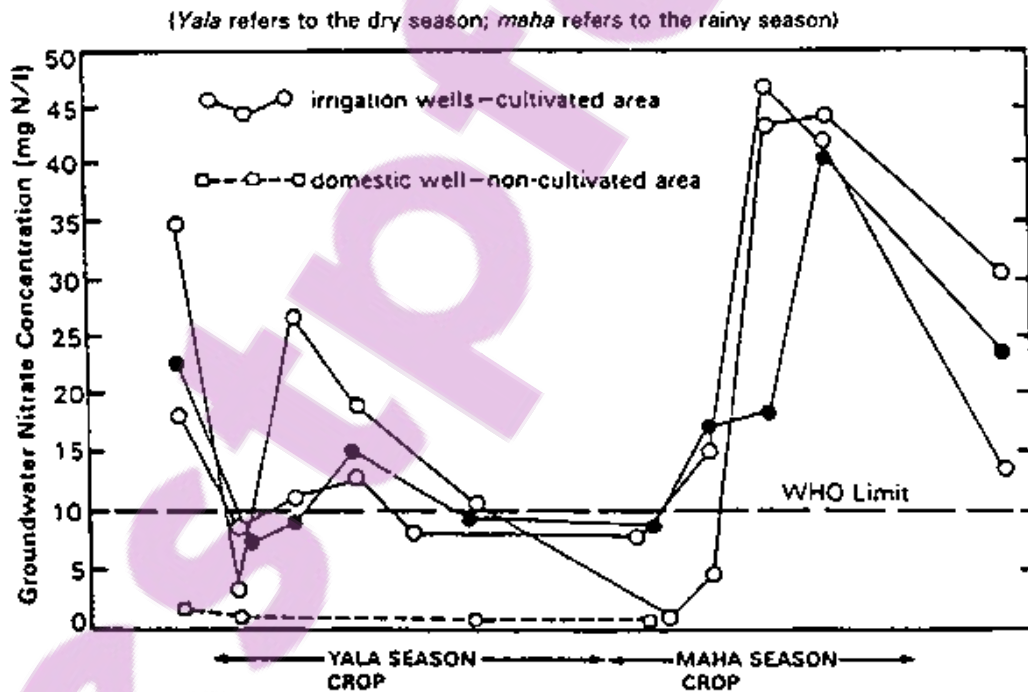

Figure 2.5 SEASONAL NITRATE VARIATIONS

Lawrence (1986) reported seasonal nitrate variations in shallow sand aquifers in Sri Lanka in areas under intensive fertilized irrigation (maha refers to the rainy season). They also mention that some other impacts agriculture might have - adverse environmental modifications result in improved breeding ground for **vectors of disease** (e.g. mosquitoes). There is a linkage between increase in malaria in several Latin American countries and reservoir construction. Schistosomiasis (Bilharziasis), a parasitic disease affecting more than 200 million people in 70 tropical and subtropical countries, has been demonstrated to increase dramatically in the population following reservoir construction for irrigation and hydroelectric power production. Reiff indicates that the two groups at greatest risk of infection are farm workers dedicated to the production of rice, sugar cane and vegetables, and children that bathe in infested water (Reiff, 1987).

Pesticides and fertilizers primarily cause the contamination of water supplies. Excessive levels of many pesticides have known **health** effects. **Microbiological** contamination of food crops stemming from use of water polluted by human wastes and run-off from grazing areas and stockyards. This applies both to use of polluted water for irrigation, and by direct contamination of foods by washing vegetables etc. in polluted water prior to sale. In many developing countries there is little or no treatment of municipal sewage, yet urban wastewater is increasingly being used directly or recycled from receiving waters, into irrigated agriculture. The most common diseases associated with contaminated irrigation waters are cholera, typhoid, ascariasis, amoebiasis, giardiasis, and enteroinvasive Ecoli. Crops that are most implicated with spread of these diseases are ground crops that are eaten raw such as cabbage, lettuce, strawberries, etc.

There is also contamination of food crops with **toxic** chemicals and miscellaneous related health effects, including treatment of seed by organic mercury compounds, turbidity (which inhibits the effectiveness of disinfection of water for potable use), etc. To this list can be added factors such as the potential for **hormonal** disruption (endocrine disruptors) in fish, animals and humans. Hormones are produced by the body's endocrine system. Because of

the critical role of hormones during early development, toxicological effects on the endocrine system often have impacts on the reproductive system (Kamrin, 1995). It is probably safe to conclude, however, that high levels of agricultural contaminants in food and water as are found in many developing countries have serious implications for reproduction and human health and the main concern is the nitrogen release.

Figure 2.6 illustrates the various forms and pathways that nitrogen (N) can take as it cycles through an agricultural production system (Lawrence, 1986). Before plants can use nitrogen, it must be converted into forms that are available to plants; this conversion is called mineralisation. The plants take up these mineral forms through their root systems and form plant proteins and other organic forms of nitrogen. Livestock eat crops and produce manure, which is returned to the soil, adding organic and mineral forms of nitrogen to the soil, which can be used again by the next crop.

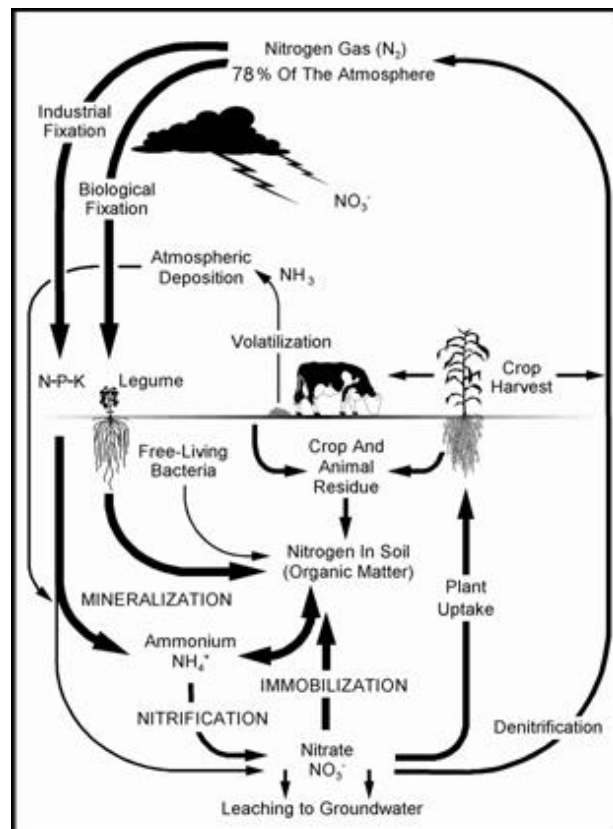

Figure 2.6 NITROGEN FORMS AND PATHWAYS WITHIN AN AGRICULTURAL PRODUCTION SYSTEM

Ideally, it would be most economically and environmentally beneficial to keep all the nitrogen in this tight cycle for food production. In reality, however, some leakage occurs. Where there is too much nitrogen leakage, there can be environmental harm.

2.6.1 Remediation

The following sections describe some general approaches and specific ways to reduce the movement of nitrate to groundwater or the movement of ammonia to surface water.

2.6.2.1 *Reduce total nitrogen loading*

- Ensure livestock feed rations are not any higher than necessary to meet production targets. This will save both feed costs and excess nitrogen loss in the manure.
- Use nitrogen from sources available on the farm first, where possible (e.g., manure), before buying any nitrogen sources produced off-farm.
- Store manure properly until it is ready for land application. Be sure your storage area is properly sited, designed and sized.
- Identify fields and areas sensitive to nitrogen in areas where nutrient applications are planned. For instance, sandy or gravelly soils, and soils with shallow water tables are more susceptible to nitrogen leaching.
- Match nitrogen applications with crop requirements. Use the spring or pre-sidedress soil nitrogen test where available (e.g., for corn and barley).
- In your Nutrient Management Plan, account for nitrogen contributions from green manure crops and any previous crop rotations.
- In your Nutrient Management Plan, account for nitrogen from any manure or biosolid application.
- Apply most of the nitrogen just before the time of maximum crop uptake (e.g., sidedress corn).
- Split applications of nitrogen through techniques such as fertigation.
- Practise crop rotations to make efficient use of nitrogen and maintain healthy soils.

- Establish cover crops as needed to “tie up” any excess nitrogen at the end of the season.
- Practice timely tillage to incorporate manure, balancing the risk of soil compaction with the losses of nitrogen to the atmosphere if the manure is not incorporated quickly.
- Avoid applying manure near surface water or on steeply sloping land.
- Keep application rates low enough to prevent run-off.
- Mix manure into the soil as soon possible after applying it.
- On tile-drained land, keep application rates of liquid manure below 40 m³/ha (3,600 gal/ac) or pre-till the field before applying it. This will help prevent the movement of manure directly to tile through cracks or earthworm channels.
- Use buffer strips and erosion control structures to filter run-off before it enters surface water. Buffer strips in riparian zones have proven to reduce nutrient movement off the field into nearby surface water sources. Buffer strips consume excess nutrients before they flow into surface water and enhance opportunities for groundwater denitrification.

In order to protect the environment from the adverse effects of agricultural programmes and projects there are a number of mitigation and management options that can be implemented. Some key options are given below. These may be undertaken individually or combined into an action plan. To achieve the best results, mitigation options should be determined through the close participation of those for whom the project is intended and those likely to be adversely affected (Ignazi, 1993).

2.6.2.2 *Mitigation and management options*

Wilderness Areas (Andreoli, 1993)

- Alternative project routing of access roads if applicable;
- Include wilderness area features in project design (e.g. fish ladders, wildlife passages or crossings);
- Establish buffer zones around wilderness or forest areas;
- Rehabilitate or create ecosystems to offset wilderness or forest conversion or add to existing stock;

- Strengthen wilderness and forest area management institutions, both governmental and non-governmental, with staff, equipment, training, and support of enforcement activities;
- Establish environmental and conservation education programmes at local schools.

Wetlands (Andreoli, 1993)

- Selection of alternative agricultural sites to avoid wetland;
- Design features to prevent disturbance of the flow patterns and hydrologic regimes critical to conservation of the wetland (e.g. flow regulating works, road crossings on trestles or pilings, rather than on embankments);
- Enhancement and/or protection of other wetland in substandard conditions to offset losses at project site;
- Artificial construction of wetland to replace areas lost (e.g. where experience has shown that the wetland type in question can in fact be constructed);
- Strengthen institutions to manage and protect wetland;
- Include NGOs in the institutional arrangements for wetland conservation;
- Promote development of national wetland incentives and management strategies;
- Require wetland concerns to be considered in national and local planning and law and incorporated into decision-making processes;
- Environmental education programmes to disseminate knowledge on the importance of wetland.

Measures for land preparation (Andreoli, 1993)

- Adopt alternative land clearing measures;
- Retain certain vegetation such as tree stumps and shrubs to help preserve soil structure and prevent soil erosion;
- Leave residual vegetation to be returned to the soil for nutrient/organic matter value;
- Market removed products to offset clearing costs,
- Identify low lying areas that could best be used for pond aquaculture;

- Require a clearing method/cover crop/cropping plan before clearing approved;
- Plant the cleared area immediately following clearance with an appropriate vegetation cover;
- Consider mitigation measures for road construction associated with agricultural projects;
- Soil suitability assessments should state what land clearing methods are assumed;
- Declare surrounding forests as wildlife preserves or forest reserves;
- Where land management systems are shown to be in transition by a socio-economic analysis, monitoring and evaluation should be built into agricultural activities to mitigate future impacts that may affect the population or resource base;
- Sustain the capability of the land under a given land use to return to its initial productivity;
- Identify and support the welfare and cultural identity of affected tribal and local peoples;
- Provide adequate extension services.

Measures for farming operations (Andreoli, 1993)

- Biological conservation techniques (both on-farm and off-farm options);
- Water conservation techniques (both on-farm and off-farm options);
- Soil conservation measures (e.g. terracing, bundling, contour ploughing);
- Judicious use and efficient application of agro-chemicals.

Institutional measures (FAO/ECE, 1991)

- Sectoral policy in favour of environmental protection;
- Fiscal and economic policies that support settled agricultural development (e.g. subsidies);
- Land tenure modifications in support of permanent agriculture;
- Environmentally responsive land-use planning - with legal basis and resources for enforcement;
- Buffer zones between forest and agriculture;

- Incorporation of 'planning gains' into land allocation and 'change of land use' to encourage agricultural activities and development.

“The Wisconsin Discovery Farms and Water Action Volunteers programs have joined forces in Wisconsin to monitor and learn about the impacts of farm practices on water quality. Discovery Farms is a programme of UW-Madison and UW-Extension, and a branch of the Wisconsin Agriculture Stewardship Initiative (WASI). The programme works with privately owned farms to identify effective and economical best management practices (BMPs) to minimise farming's impact on the environment and create sound, science-based environmental regulations for agriculture.

Water Action Volunteers (WAV) is a programme for Wisconsin citizens who want to learn about and improve the quality of Wisconsin's streams and rivers and includes a Citizen Stream Monitoring component (FAO/ECE, 1991). WAV coordinator, Kris Stepenuck, has teamed with Dennis Frame of Discovery Farms in the Trained Local Samplers (TLS) program. The TLS programme works with people located in proximity to the Discovery Farms, teaching them how to properly take water samples and several other measurements that help determine stream health. Stepenuck and Discovery Farms Senior Scientist, Wes Jarrell, along with other area specialists, conducted the first three on-farm training sessions in 2002. Regular sampling has begun on those farms.

The samplers conduct tests for dissolved oxygen, temperature, turbidity, pH, alkalinity, nitrate, ammonia, conductivity and stream flow every other week on the Discovery Farms. In addition, they will collect grab samples of water once each season; these samples will be sent to a local lab for more detailed testing, including nitrogen and phosphorus analysis. Biotic Index (using aquatic macro-invertebrates) will be evaluated twice per year and habitat assessments will be conducted once per year (FARM & HOME ENV MNG, 2008).”

All nine pilot state partners of the Livestock Environmental Management Systems Project met in Denver in January 1991 to discuss the progress of their efforts and future directions. Attendees were treated to training on various

aspects of farm environmental management systems, including a "virtual tour" of a couple of farms, and an exercise on creating daily, weekly, monthly and annual environmental checklists for different commodity types of farms. The draft "EMS Guidebook" was a major focus of discussion, as it is being pilot tested by the projects as they work with farmers in their states to develop EMSs (FAO/ECE, 1991).

Taking advantage of an opportunity in Texas, the team there has refocused its approach from piloting comprehensive EMSs on beef farms to managing dust, odour and other air-quality parameters not currently regulated under Texas' existing CAFO permit programmes. This "modular EMS" takes full advantage of existing research and technology-transfer priorities expressed by the Texas Cattle Feeders Association. This new approach would replace the original effort to steer cooperating feed yards through the comprehensive EMS, which would be highly duplicative of NPDES permit provisions, especially in on-site environmental assessments of aspects already subject to regulatory inspections, record keeping and emergency-response planning requirements. The likelihood of eventual project success is much greater with the new mission, reports Auvermann (FAO/ECE, 1991).

In Wisconsin, the pilot project held a training session for agriculture educators on assessment software. The pilot state also held its third stakeholder meeting in February 1991, which included parties from the dairy industry, insurance companies, environmental organisations, university staff, agribusiness associations and state and federal agencies. The team is piloting its version of the EMS guidebook at nearby UW Research Stations.

Georgia continues to work with groups of stakeholders, including Georgia Poultry, the U.S. Poultry and Ag Federation, and Goldkist. Some producers have stepped forward as volunteers, while Goldkist sponsored others. The project is testing three different approaches to working with farmers who want to develop the EMS: (1) coaching by project staff; (2) farmers using the guidebook on their own; and (3) working with consultants. The pilot group is planning an early summer meeting with participants, and a late summer/early fall Georgia

summit or roundtable for all the stakeholders to hear about the farmers' experiences.

New strategies for managing water and soil in Australia's extensive dryland agricultural landscapes are critical to the future of Australia's rural communities. These require the development and improvement of land management practices that are economically viable, environmentally sustainable and socially acceptable. The quantity and quality of water flowing in rivers is highly dependent on how dryland agriculture is managed. CSIRO has expertise in the sciences associated with the balance and fate of water and nutrients in dryland agriculture, at scales ranging from a few millimetres to river catchments (FAO/ECE, 1991).

In delivering their **research to industry**, they place the biophysical impacts of agriculture in their environmental and societal context:

- Understanding the environmental impacts of agricultural systems;
- Developing rapid measuring technologies suitable for surveying large areas;
- Developing technology for predicting soil properties and conceptualising landscape processes;
- Finding innovative applications of new monitoring technologies for land managers;
- Improved numerical simulation models for systems analysis of agricultural landscapes;
- Developing of predictive modelling for the management of agricultural landscapes;
- New landscape management options based on soil distribution, topography and the related landscape;
- Identifying novel mixes of annual and perennial planting agronomy, rotations and combinations;
- Developing of commercially-driven tree/crop production systems;
- Creating new forms of cereals, pulses, oilseeds and forages selected or bred for characteristics that substantially reduce deep drainage and nitrogen leakage.

CSIRO draws on current knowledge in catchment water and solute transport and works with other disciplines and organisations to drive improved prioritisation of Natural Resource Management (NRM) investment.

2.7 Conclusion

A detailed literature survey was done on all the expected impacts that might occur. Using this valuable information an analysis will be done and the best mitigation methods will be investigated to treat the different impacts on the water quality and volume.

Chapter 3

DATA COLLECTION AND DISCUSSION OF RESULTS

3.1 Introduction

Five contributors were identified as the main polluters, namely old mine workings that are currently decanting 15 MI of acid mine drainage per day, two informal settlements, a sewage treatment plant, the Cooke tailings dam and some agricultural activities.

To determine the various impacts initial personal interviews were done with the local residents in the two townships, as well as with the mine's environmental manager and primary-treatment supervisor. To establish the water quality impact water samples were taken at the monitoring points. The volume of water flow was measured at strategic sites to assist in calculating the load of chemical composition and loss or accumulation of water in the system. A detailed discussion will follow where the water quality samples provide a good indication of the point source contaminants.

The macro-invertebrate assemblage also provides a good indication of the biological health of an aquatic environment. The macro-invertebrate assessment was done using the SASS5 (South African Scoring System version 5) method to determine the microbial impact that the sewage works might have.

Aerial photographs were visually interpreted to determine other impacts in the vicinity, like agricultural or industrial activities, township size and mining facilities. The current wetland size has been measured and the impact on the volume due to evapo-transpiration was calculated using the A-Pan formula and vegetation cover of the study area

3.2 Impacts

The five main impactors were identified and listed above. An impact evaluation table was drawn-up according to the impacts identified in the literature review relating to each of the five sources of impacts (see *Table 3.1*).

Table 3.1 IMPACT EVALUATION TABLE

Impactors	pH	Conductivity	Total Dissolved Solids	Sulphate	Nitrate	Total Alkalinity	Iron	Microbial	Volume
Acid mine drainage	X			X			X		X
Informal settlements	X	X	X		X			X	X
Sewage works	X							X	X
Tailings dam			X						
Agricultural activities		X			X			X	

Based on this table the following elements will be investigated:

Water quality

- pH
- conductivity
- total dissolved solids
- sulphate
- nitrate
- total alkalinity
- iron
- microbial

Water volume

- Hydrology water balance
- Evapo-transpiration
- Vegetation cover
- Impact model

3.3 Water quality

3.3.1 Sampling

3.3.1.1 Description of monitoring sites

The control monitoring site (CS) was selected at the water crossing of the Provincial Road (R41) which forms the northern most boundary of the study area (see *Figure 3.1a* & *Figure 3.1b*). Water that enters the study area at this point has already been subjected to several impacts because of the mining industry and human settlements. All the results obtained from this site are used as control (base line) values for this assessment.

Monitoring sites (MS)

- MS01** Located immediately after the inflow of sewerage effluent from the Flip Human Sewerage Treatment Plant. Daily approximately 35MI of water is dispersed into the stream by the sewerage plant at this point.
- MS02** Located at the head of the Cook Metallurgical Plant attenuation dam at the southern tip of the large reed bed located downstream of MS01.
- MS03** Located in the Cook attenuation dam at the point of water dispersion originating from the water treatment plant of the Harmony Gold, Randfontein Estate gold mine.
- MS04** Located downstream of the attenuation dam, in the reed bed, opposite the storm water culverts of the Cook Metallurgical Plant. Water quality may be influenced by storm water run-off from the plant at this locality.
- MS05** Located in the reed bed at the point of entry of the drainage line originating beneath the South Roodepoort tailings dam. This sampling point was dry, and no data was available.
- MS06** Located at the water crossing opposite the Cooke tailings dam. The combined flow at the water crossing and an irrigation channel diverting water to a nearby farm was measured at this site.
- MS07** Located immediately north of the Provincial Road (R559). This site was included to monitor the possible impacts due to nearby agricultural activities.
- MS08** Located in the reed bed south of the R559 opposite Cooke Plant no. 1. Mine effluent originating from Cook Plant no. 2 may have an effect on water quality in this area.
- MS09** This sampling point was dry thus no data was available.
- MS10** Located in the reed bed downstream of the vent shaft located north of Cooke Plant no. 2.
- MS11** Located immediately north of the water crossing before inflow into the Donaldson Dam. An informal settlement is present to the west of the reed bed.
- MS12** Located in the Donaldson Dam at the water overflow culvert from the first cell to the second cell in the dam.
- MS13** Located at the overflow of the Donaldson Dam where the water enters the pipeline towards the Mooi River catchment.

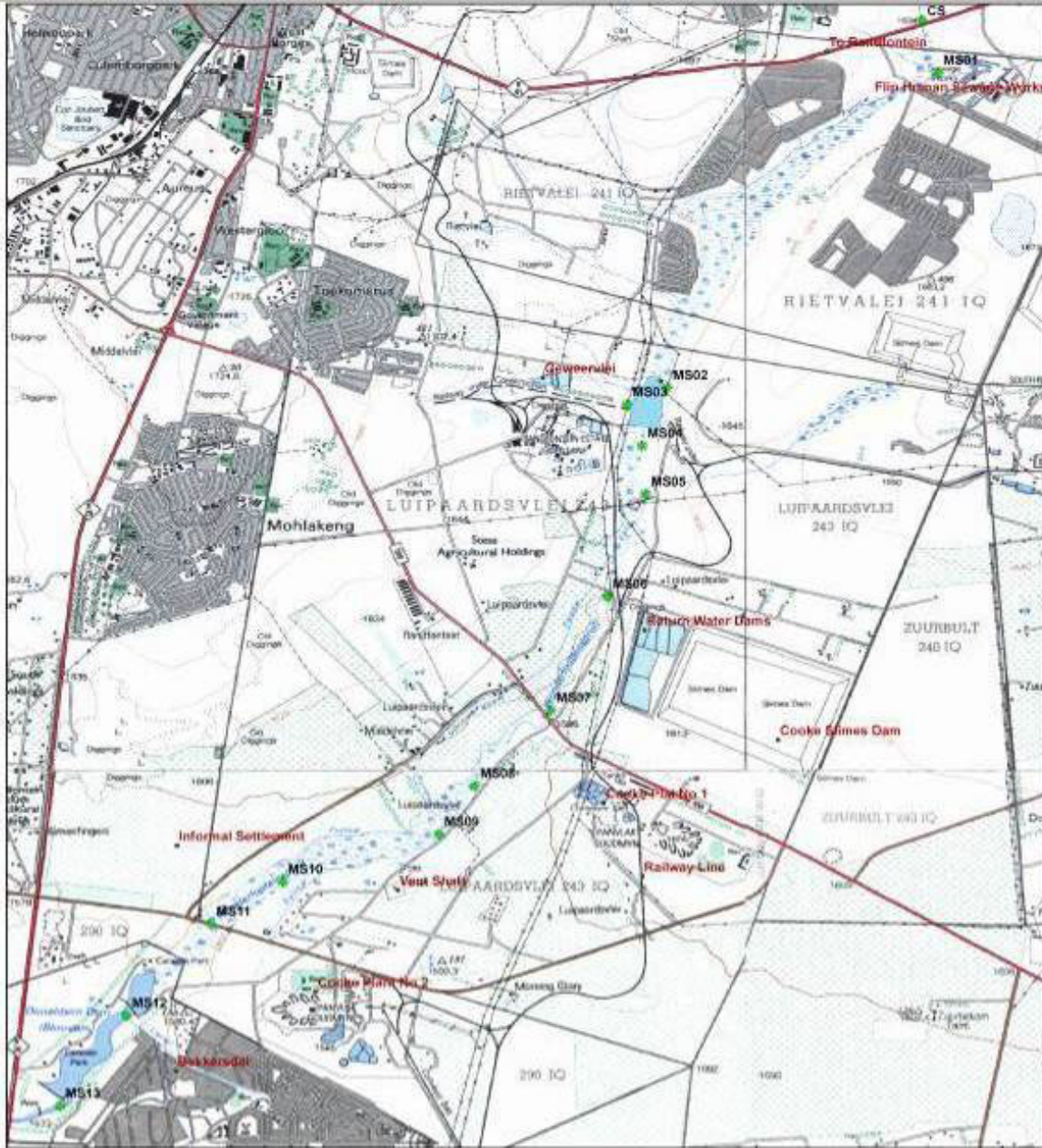

Figure 3.1a MONITORING POINTS OF WONDERFONTEINSPRUIT (Overall view)

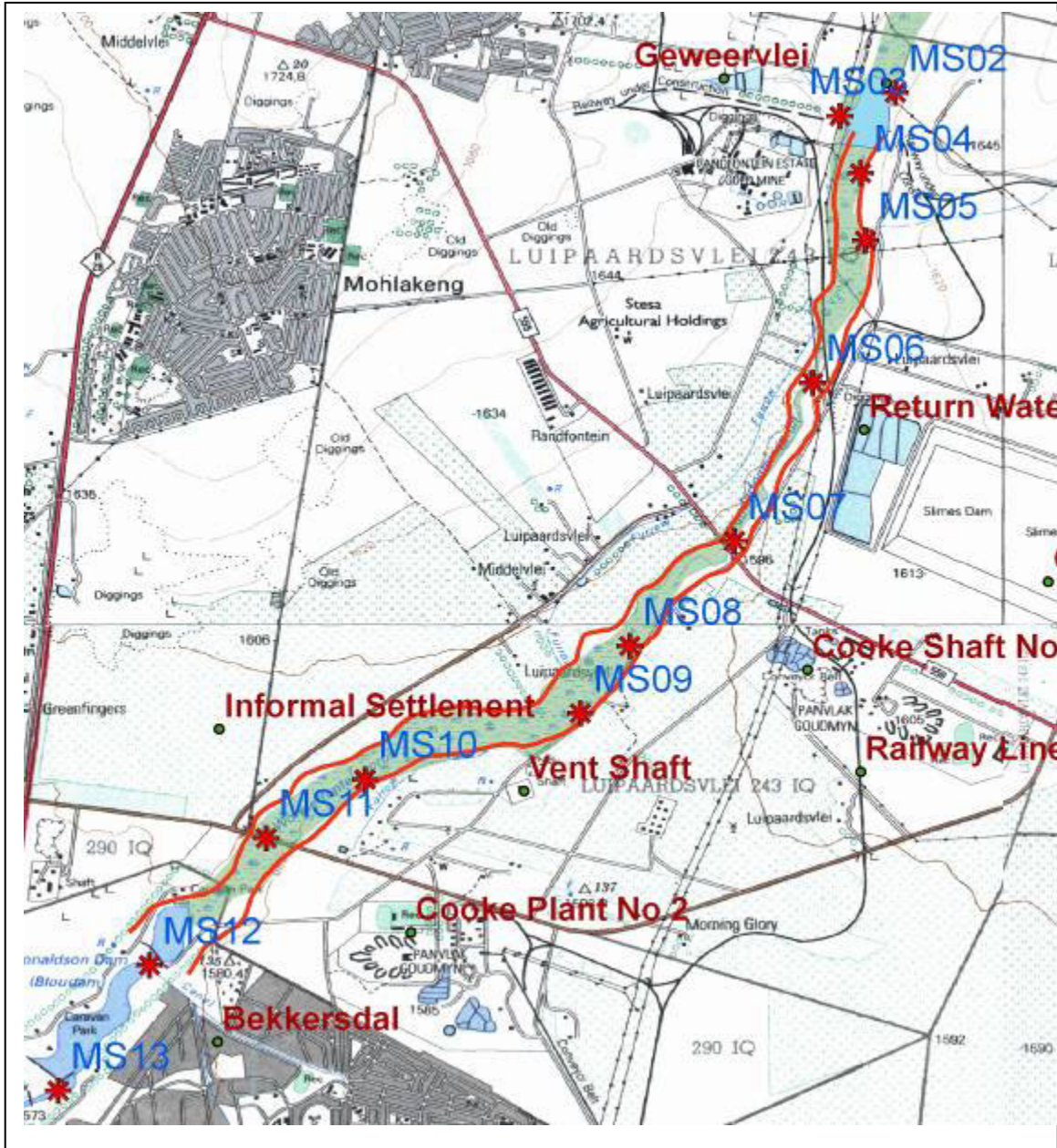

Figure 3.1b MONITORING POINTS OF WONDERFONTEINSPRUIT (Study area)

3.3.1.2 Background of monitoring points

The Flip Human Sewage Plant discharges an average of 23.0 MI/day (MS01). At the point where the Sewage Plant discharges its effluent, the character of the water in the Wonderfonteinspruit changes altogether. Up to this point, the water had a predominantly mining character with high sulphate and TDS loads and a relatively low flow rate. After the sewage effluent discharge point, the water has a more natural character and is not dominated so much by the gold mining industry. The flow rate also increases significantly.

From the Flip Human Sewage Plant, the Wonderfonteinspruit flows through an extensive reed bed for a distance of approximately 4.8 Km. In places, this reed bed is over 500 m wide. This section of the Wonderfonteinspruit ends in the Cooke Attenuation Dam, constructed by the gold mines in the area to attenuate storm water through the middle Wonderfonteinspruit. This dam has, however, never been used for its intended purpose. This dam also marks the beginning of the study area for this particular project.

The Cooke Attenuation Dam (MS02) has a gross storage capacity of 2 100 MI of which 1 800 MI can be used for attenuation purposes. It has a catchment of approximately 74 Km². About 15 MI of treated Western Basin mine void water is discharged into this dam daily. This water originates from the decant point in the Tweelopiespruit where contaminated water flows from an old black reef incline shaft referred to as BRI. The water is intercepted at the decant point and pumped to a treatment plant where excess lime is added to the water and it is aerated prior to it being settled. In accordance with the Directive from DWAF, 15 MI of this semi-treated water is then pumped to the Cooke Attenuation Dam.

The section of the Wonderfonteinspruit downstream from the Cooke Attenuation Dam is impacted both by mining activities, as well as by farming along the banks of the stream. The mining impact comes from Harmony Gold Mining Co Ltd, Randfontein Operations (hereafter referred to as Harmony). Harmony has a gold

plant named the Cooke Plant immediately downstream from the Cooke Attenuation Dam on the western side of the stream. This plant (MS04) is known to have regular spillages of contaminated water, into the Wonderfonteinspruit.

Some two Km downstream from Cooke Plant is the Cooke tailings dam (MS06) on the eastern side of the stream. Tailings material is pumped across the stream from Cooke Plant to the tailings dam. As is the case with Cooke Plant, this tailings dam often causes spillages into the Wonderfonteinspruit. Although the Wonderfonteinspruit flows through an extensive wetland at this point and the reeds, especially the anaerobic conditions within the root zone of the reed beds, could be conducive to sulphate breakdown. It is believed that this may not be the only cause for the progressive downstream decrease in the sulphate concentration. It should also be kept in mind that the dolomitic water entering the Wonderfonteinspruit after the Cooke tailings dam might already be contaminated with sulphates from this tailings dam and that, depending on the concentration of the groundwater, a much greater volume would be required to dilute the sulphate concentration in the Wonderfonteinspruit.

About 1.5 Km downstream from the Cooke tailings dam is the Cooke 1 shaft (MS08). Surplus underground water is discharged into the Wonderfonteinspruit from this shaft. It is therefore understandable that the sulphate concentration would rise as the Wonderfonteinspruit passes these point pollution sources.

From the Cooke 1 shaft the Wonderfonteinspruit traverses another 5.7 Km before reaching its last impoundment before entering a 1-meter diameter pipeline. This is the Donaldson Dam. The Donaldson Dam actually comprises two separate dams, an upper and lower dam. It has a storage capacity of approximately 1 000 MI but cannot be used as an attenuation dam.

Along the 5.7 Km downstream from Cooke 1 shaft, farming activities (MS10) mostly flanks the Wonderfonteinspruit. Shortly after the Cooke Attenuation Dam, a

canal leaves the Wonderfonteinspruit on its western side. This water is used for irrigation purposes and for the watering of livestock.

From the Donaldson Dam, the flow of the Wonderfonteinspruit (MS12) is diverted into a pipeline, initially a 700 mm pipe for approximately 1.5 Km up to a weir and from there onwards, a 1-metre pipe. The entire length of the pipeline is approximately 32.5 Km up to Carletonville. The reason for construction of the pipeline in the 1960's was to divert the flow of the Wonderfonteinspruit across the dewatered Gembokfontein and Bank dolomitic compartments. These compartments were dewatered to enable the mining of gold reefs below the dolomite.

3.3.1.3 Chemical analysis

Water quality is a broad term used for the various chemical (phosphate, iron, etc.), physical (temperature, turbidity, etc.) and biological (bacteria, algae, etc.) constituents of water. Water resources exposed to pollutants may contain high levels of heavy metals (copper, zinc, chromium, etc.), nutrients (nitrite, phosphate, etc.) and/or the physical characteristics (temperature, oxygen content, conductivity etc.) may change. Changes in water quality act as important indicators to establish the degree of impact human activities have on a catchment. Unmanaged urbanisation, industrial, mining and agricultural activities can result in a deterioration of the surface and ground water quality within the catchment. Pollutants resulting from these activities accumulate in rivers, dams and underground aquifers. In order to identify and quantify the impact of the mine water and other human activities on the Wonderfonteinspruit, it was of utmost importance to do a chemical analysis of the water quality.

Sterile sampling bottles were obtained from DD Science cc Laboratory (SANAS Accredited) for taking: 1) water samples for chemical analyses; 2) water samples

Table 3.2 WATER ANALYSIS OF WONDERFONTEINSPRUIT

		Sample ID and Lab ID													
Chem. Analysis	Units	SABS Guidelines		CS	MS01	MS02	MS03	MS04	MS06	MS07	MS08	MS10	MS11	MS12	MS13
		Class 0	Class 1	Class 2	1255/1	1255/2	1255/3	1255/4	1255/5	1255/7	1255/8	1255/10	1255/12	1255/13	1255/14
pH	@25°C	6-9	5 - 9.5	4-10	7.3	7.9	8.1	8.3	7.9	8.0	8.1	8.1	7.6	8.2	8.3
Conductivity	mS/m @25°C	<70	70 - 150	150-370	45	76	90	111	102	111	141	178	149	147	141
Tot. dissolved solids	mg/l @180°C	<450	450 - 1000	1000-2400	373	511	638	882	771	860	887	1585	1220	1220	1160
Sulphate	mg/l	<200	200-400	400-600	162	65	80	354	237	437	318	823	550	592	574
Nitrate	mg/l N	-	-	-	3.5	8.6	0.9	5.4	3.1	1.8	3.6	2.1	2.7	6.2	4.9
Total alkalinity	mg/l CaCO ₃	-	-	-	75	264	336	216	258	250	241	185	236	214	175
Iron	mg/l	<0.01	0.01-0.2	0.2-2	<0.1	<0.1	<0.1	<0.1	<0.1	0.1	<0.1	0.3	<0.1	<0.1	<0.1

for bacteria analyses; while sterile sample sachets were used for 3) sediment samples. The same sampling points were used as previously discussed in this report (see *Figure 3.1*). Samples collected at the abovementioned sample points were analysed for the following: pH, conductivity, TDS, sulphates, nitrates, total alkalinity and Fe. Results obtained were used to calculate the local increase of the relevant substance at each site. The results of the chemical analyses are illustrated in Table 3.2 with the appropriate SABS guidelines for drinking water.

3.3.2 Discussion on analysis

The results of the investigation relating to water quality indicators identified are now discussed. The eight measures of water quality that were investigated are: pH; conductivity; total dissolved solids; sulphate; nitrate; total alkalinity; iron; microbial.

3.3.2.1 pH

The pH value is a measure of the hydrogen ion activity in a water sample. It is mathematically related to hydrogen ion activity according to the expression:

$$\text{pH} = -\log [\text{H}^+], \text{ where } [\text{H}^+] \text{ is the hydrogen ion activity.}$$

The pH of pure water (that is, water containing no solutes) at a temperature of 24 °C is 7.0, the number of H⁺ and OH⁻ ions are equal and the water is therefore electrochemically neutral. As the concentration of hydrogen ions [H⁺] increases, pH decreases and the solution becomes more acid. As [H⁺] decreases, pH increases and the solution becomes more basic (Golterman, Clymo & Ohnstad, 1978).

For surface water, pH values typically range between 4 and 11. The relative proportions of the major ions, and in consequence the pH, of natural waters, are determined by geological and atmospheric influences. Most fresh waters, in South Africa, are relatively well buffered and more or less neutral, with pH ranges between 6 and 8 (Day & King, 1995). According to the SABS standard pH at 25°C can be classed as follows: Class 0 between 6-9, class 1 in the range of

Wonderfontein Spruit pH

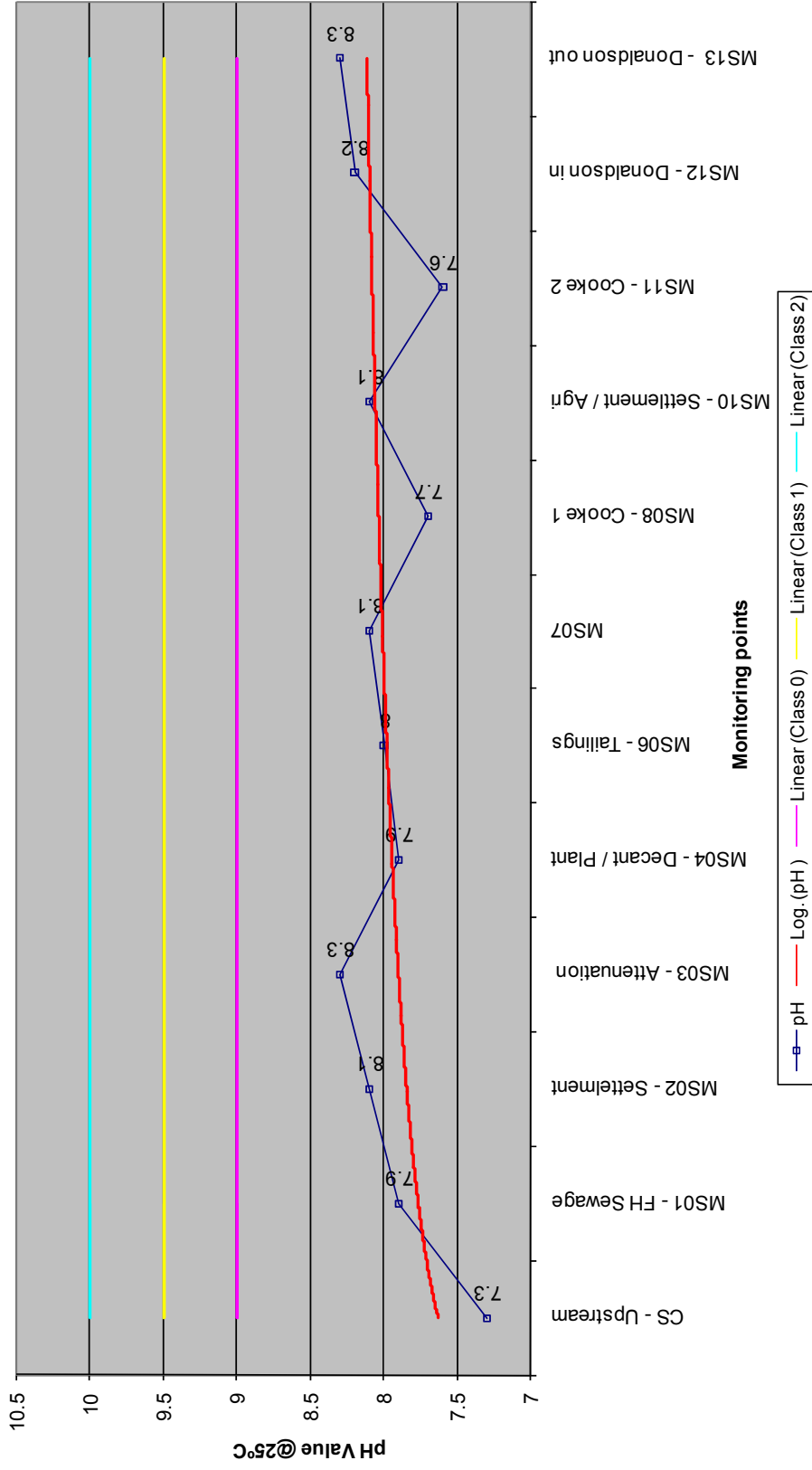

Figure 3.2 pH LEVELS

5-9.5 and class 2 between 4-10. To better understand the graphs and to avoid any complication only the maximum value per class were indicated. When the pH falls in class 0, this indicates an ideal drinking water and no further action and investigation are necessary.

The results (see *Figure 3.2*) indicate that the relative neutral pH water enters the stream there is a definitive increase in the pH due to the informal settlement and the Flip Human sewage works. Elevated pH values may be caused by increased biological activity in eutrophic systems. Thus the main reason for the rising pH is the Flip Human Sewage Treatment Works effluent that definitely stimulates increased biological activity.

At sampling point number 3 (MS03) the acid mine drainage enters the stream. A sharp decrease in the pH can be seen as is expected from AMD water. This is confirmed by the literature review and it is expected to have a very low pH. The other impacts can be seen at point 8 (MS08) and 11 (MS11) where the mining impact of Cooke plant 1 and Cooke plant 2 can be seen. It is the same AMD effluent as the decant water that is impacting on the stream. Although an increase can be seen in *Figure 3.2* in the overall trend line, the pH value still indicates a very good class of water, that falls within Class 0 (between pH 6-9).

3.3.2.2 Conductivity

Conductivity of a substance is defined as 'the ability or power to conduct or transmit heat, electricity, or sound'. Its units are Siemens per meter [S/m] in SI and micromhos per centimetre [mmho/cm] in U.S. customary units. Its symbol is k or s . Conductivity is a measurement of the ability of an aqueous solution to carry an electrical current. An ion is an atom of an element that has gained or lost an electron, which will create a negative or positive state.

For example, sodium chloride (table salt) consists of sodium ions (Na^+) and chloride ions (Cl^-) held together in a crystal. In water it breaks apart into an

aqueous solution of sodium and chloride ions. This solution will conduct an electrical current. The equation below illustrates this (Golterman, 1978):

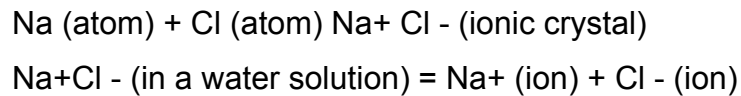

There are several factors that determine the degree to which water will carry an electrical current. These include: the concentration or number of ions; mobility of the ion; oxidation state (valence); and temperature of the water. Resistance, which is an electrical measurement expressed in ohms, is the opposite of conductivity. Conductivity is then expressed in reciprocal ohms. A more convenient unit of measurement in the chemical analysis of water is micromhos. The specific conductance or conductivity measurement is related to ionic strength and does not tell us what specific ions are present.

Conductivity is a measurement used to determine a number of applications related to water quality. As determining mineralisation: this is commonly called total dissolved solids. Total dissolved solids information is used to determine the overall ionic effect in a water source. The number of available ions in the water often affects certain physiological effects on plants and animals. Because a direct link is always expected between electric conductivity and total dissolved solids and in this study it can clearly be seen the EC and TDS value graphs (see *Figure 3.3 & Figure 3.4*) will be discussed together.

3.3.2.3 Total dissolved solids and conductivity

The total dissolved solids concentration is a measure of the quantity of all compounds dissolved in water. The total dissolved salts concentration is a measure of the quantity of all dissolved compounds in water that carry an electrical charge. Since most dissolved substances in water carry an electrical charge, the TDSalts concentration is usually, used as an estimate of the concentration of total dissolved solids in the water.

The TDSalts concentration is directly proportional to the electrical conductivity (EC) of water. Because EC is much easier to measure than TDSalts, it is routinely used as an estimate of the TDSalts concentration. Therefore, it has become common practice to use the total dissolved salts concentration, as a measure for the total dissolved solids.

Natural waters contain varying quantities of TDS as a consequence of the dissolution of minerals in rocks, soils and decomposing plant material, the TDS concentrations of natural waters therefore being dependent at least in part on the characteristics of the geological formations with which the water has been in contact. The TDS concentration also depends on physical processes such as evaporation and rainfall (ANZECC, 1992).

Salts accumulate as water moves downstream because salts are continuously being added through natural and anthropogenic sources whilst very little is removed by precipitation or natural processes. Domestic and industrial effluent discharges and surface runoff from urban, industrial and cultivated areas are examples of the types of sources that may contribute to increased TDS concentrations. Evaporation also leads to an increase in the total salts (Michaud, 1991).

In the Wonderfonteinspruit study there are numerous contributors to the dissolved solid and salt load like the informal settlement the tailings dam and the Flip Human effluent plant, alkalinity levels also decreases as indicator of the increasing salt load as flow diminishes. The proportional concentrations of the major ions affect the buffering capacity of the water and hence the metabolism of organisms. Secondary effects include those on water chemistry, which in turn affect the fate and impact on the aquatic environment of other chemical constituents or contaminants (Michaud, 1991).

Wonderfontein Spruit Conductivity

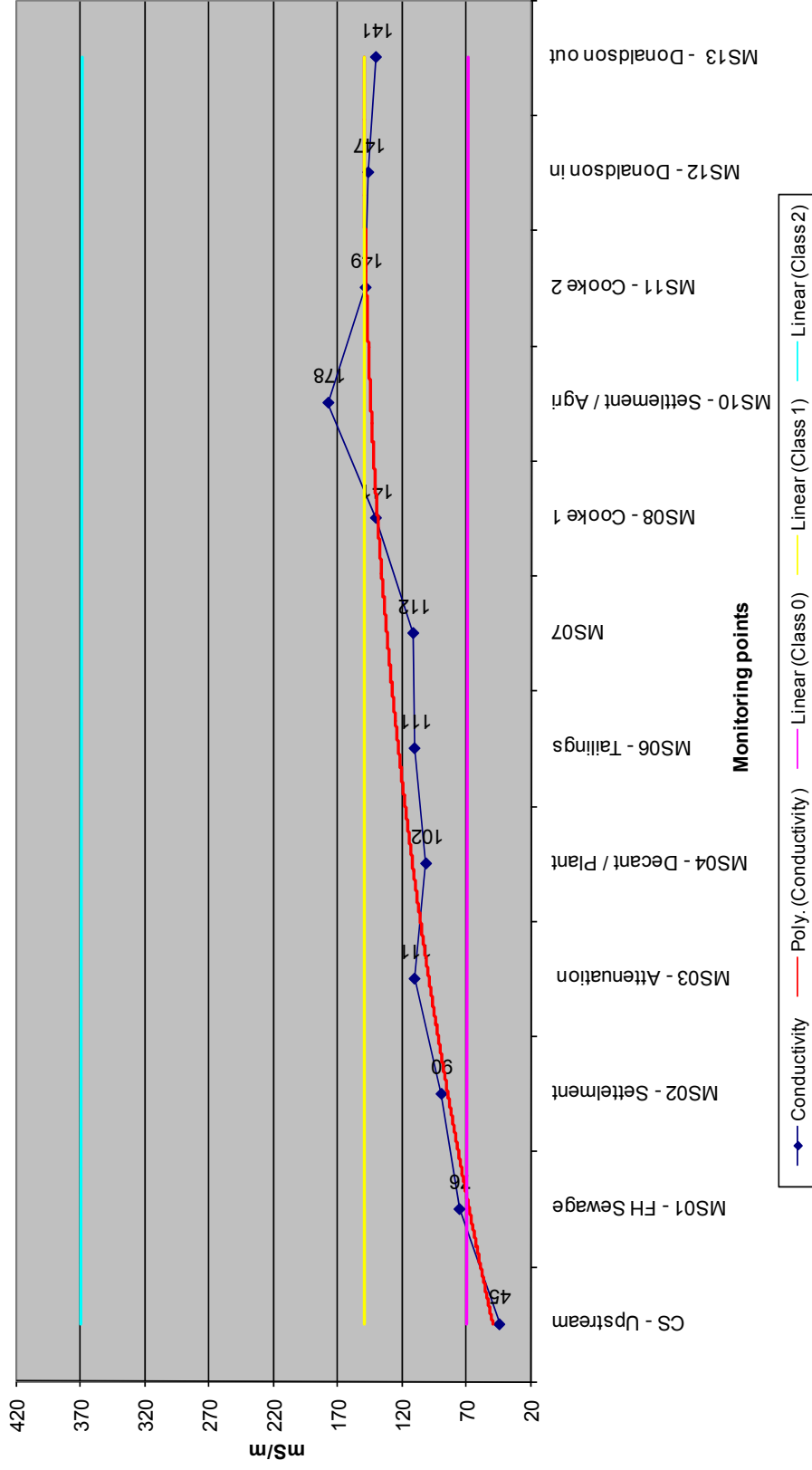

Figure 3.3 CONDUCTIVITY

Wonderfontein Spruit Total Dissolved Solids

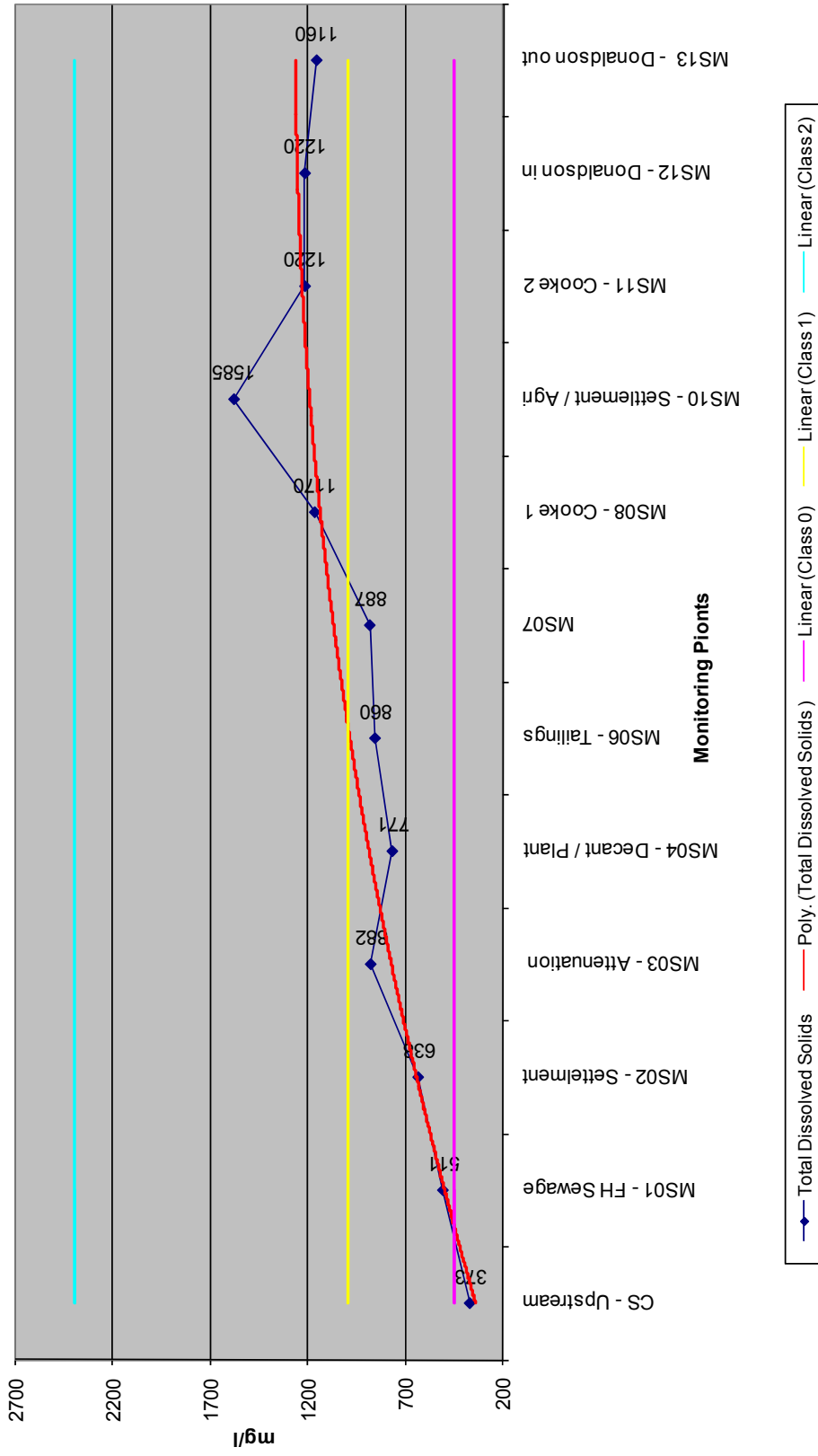

Figure 3.4 TOTAL DISSOLVED SOLIDS

Plants and animals possess a wide range of physiological mechanisms and adaptations to maintain the necessary balance of water and dissolved ions in cells and tissues. This ability is extremely important in any consideration of the effects of changes in total dissolved solids on aquatic organisms (Day, 1993). The individual ions making up the TDS also exert physiological effects on aquatic organisms. Changes in the concentration of the total dissolved solids can affect aquatic organisms at three levels, namely: effects on, and adaptations of, individual species; effects on community structure; and effects on microbial and ecological processes such as rates of metabolism and nutrient cycling.

Flow values gradually decreases in the system and this reduction in flow also has an impact on the salt load in the water. This is reflected in the conductivity values that steadily increase over the length of the study area. Alkalinity levels also decrease as indicator of the increasing salt load as flow diminishes. The conductivity and total dissolved solids sampled at the control point upstream of the study area are below the class 0 standard indicating that they are highly impacted on (see *Figure 3.3 & Figure 3.4*).

All the factors discussed earlier contribute to the TDS and EC values. If the graphs for both are analysed, a definite decrease can be seen at two areas between sampling point 3 and 4 and again between sampling points 10 and 11. The topocadastral maps indicate a dense reed bed in both these areas, proving the theory that wetlands can improve TDS and EC dramatically. Total dissolved solids are then identified as one of the main factors that should be addressed in the mitigation.

3.3.2.4 Sulphate

Sulphate is the oxy-anion of sulphur in the +VI oxidation state and forms salts with various cations such as potassium, sodium, calcium, magnesium, barium, lead and ammonium. Potassium, sodium, magnesium and ammonium sulphates are highly soluble, whereas calcium sulphate is partially soluble and barium and lead

sulphates are insoluble. Consumption of excessive amounts of sulphate in water typically results in diarrhoea. Sulphate imparts a bitter or salty taste to water, and is associated with varying degrees of unpalatability. High concentrations of sulphate exert predominantly acute health effects (diarrhoea). These are temporary and reversible since sulphate is rapidly excreted in the urine. Individuals exposed to elevated sulphate concentrations in their drinking water for long periods, usually become adapted and cease to experience these effects (Kempster & Smith, 1985).

Sulphate is a common constituent of water and arises from the dissolution of mineral sulphates in soil and rock, particularly calcium sulphate (gypsum) and other partially soluble sulphate minerals. Since most sulphates are soluble in water, and calcium sulphate relatively soluble, sulphates when added to water tend to accumulate to progressively increasing concentrations. Typically, the concentration of sulphate in surface water is 5 mg/R, although concentrations of several 100 mg/R may occur where dissolution of sulphate minerals or discharge of sulphate rich effluents from acid mine drainage takes place (Buisman, Lettiunga, Paasschens & Habets, 1991). The sulphate levels more than triple over the length of the stream from the attenuation dam to the outflow of Donaldson dam (see *Figure 3.5*).

Sulphates can be removed or added to water by ion exchange processes, and microbiological reduction or oxidation can interconvert sulphur and sulphate. The microbiological processes tend to be slow and require anaerobic conditions usually only found in sediments and soils. Wetland conditions are perfect for the aerobic and anaerobic processes that are needed to remove the sulphate. This option will be discussed at a later stage in this report.

It appears, from the increase at the Cooke attenuation dam at sample point 03 (MS03), that a significant amount of sulphate-containing water must be entering the stream from decant water. Sample MS06 indicates an impact from the Tailings dam as was predicted by the literature review. After Cooke tailings dam, the

Wonderfontein Spruit Sulphate

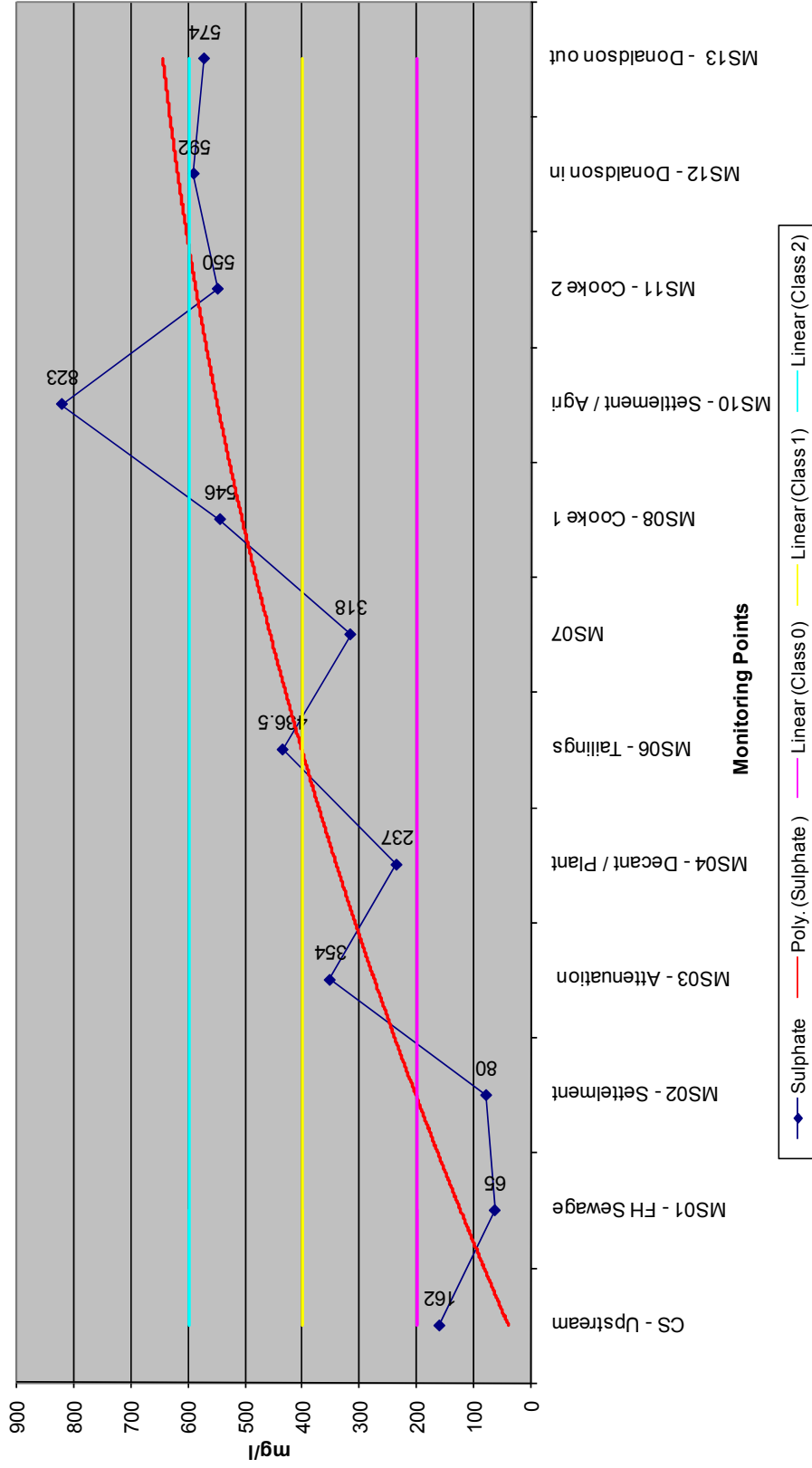

Figure 3.5 SULPHATES

sulphate shows a decline, which could be attributed to relatively clean groundwater diluting the sulphate concentration in the water.

A third major peak in sulphate levels may be attributed to both the Cooke Plant no 1, the informal settlement and agricultural activities before the dilution effect of the Cooke 2 Sewage Plant's effluent that can be seen in sample point 011 where the sulphate concentration shows another decline. The concern here is that there is not sufficient dilution to bring the sulphate in the river water back to an acceptable level as the water leaving the Donaldson Dam into the pipeline still has a sulphate concentration of 547 mg/l (Class 2). The steady decline in the sulphate concentration of the downstream from the Cooke Plant can therefore only be attributed to dilution from a relatively clean water source, containing fewer sulphates than the stream itself. The most obvious source is dolomitic groundwater. Sulphate is also recognised as a key factor that should be addressed in the mitigation measures.

3.3.2.5 Nitrate

Nitrate is the end product of the oxidation of ammonia or nitrite. Nitrate (NO_3^-) and nitrite (NO_2^-) are the oxyanions of nitrogen in which nitrogen is found in the +V and +III oxidation states, respectively. Nitrates and nitrites occur together in the environment and interconversion readily occurs. Under oxidising conditions nitrite is converted to nitrate, which is the most stable positive oxidation state of nitrogen and far more common in the aquatic environment than nitrite (Gilliam, Skaggs & Weed, 1978).

A significant source of nitrates in natural water results from the oxidation of vegetable and animal debris and animal and human excrement. Treated Sewage wastes also contain elevated concentrations of nitrate. Nitrate tends to increase in shallow ground water sources in association with agricultural and urban runoff, especially in densely populated areas. Nitrate together with phosphates stimulate plant growth. In aquatic systems elevated concentrations generally give rise to the

Wonderfontein Spruit Nitrate

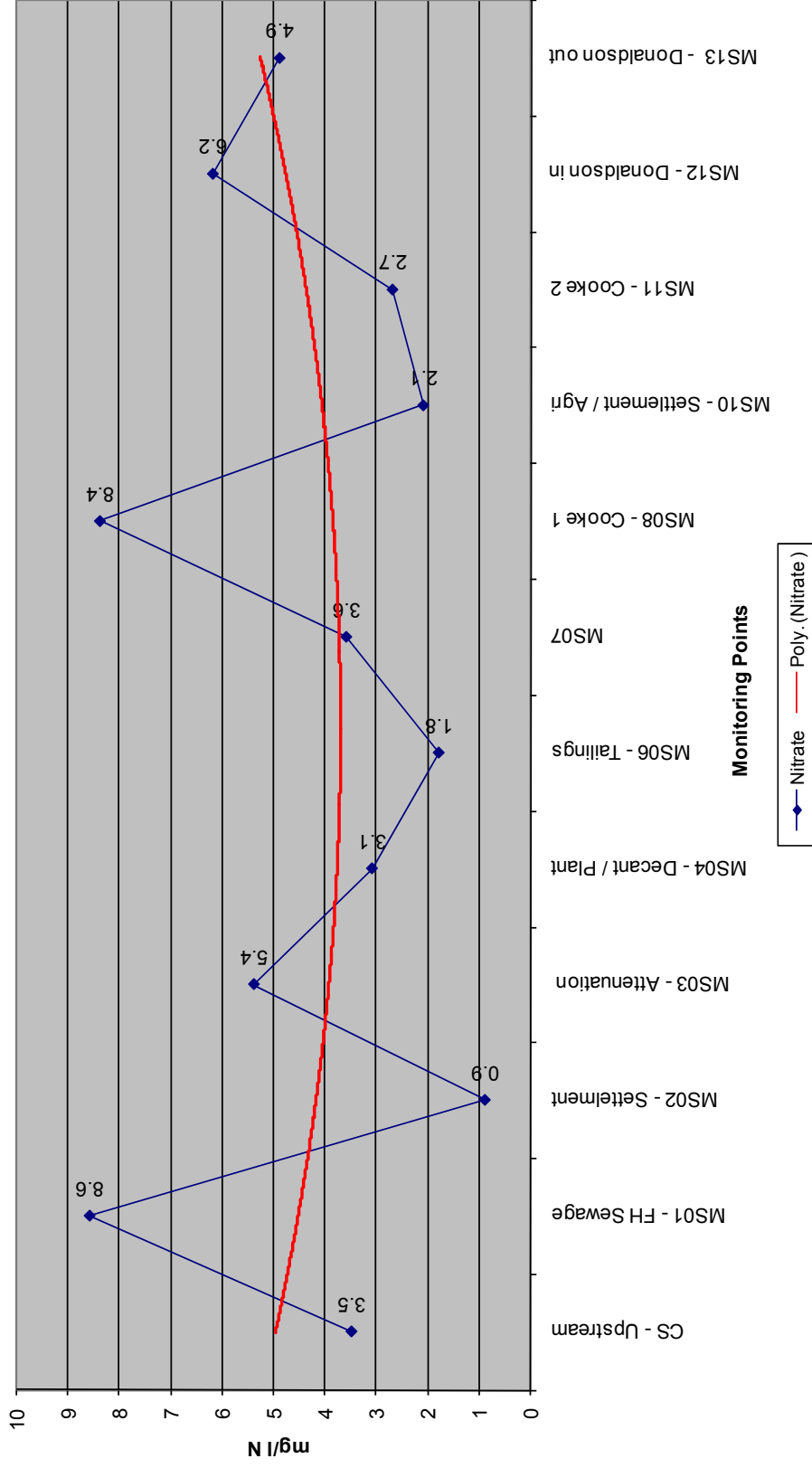

Figure 3.6 NITRATES

accelerated growth of algae and the occurrence of algal blooms. Algal blooms may subsequently cause problems associated with malodours and tastes in water and the possible occurrence of toxicity.

Upon absorption, nitrite combines with the oxygen-carrying red blood pigment, haemoglobin, to form methaemoglobin, which is incapable of carrying oxygen. This condition is termed methaemoglobinaemia. The reaction of nitrite with haemoglobin can be particularly hazardous in infants under three months of age and is compounded when the intake of Vitamin C is inadequate. Metabolically, nitrates may react with secondary and tertiary amines and amides, commonly derived from food, to form nitrosamines that are known carcinogens. A diet, adequate in Vitamin C, partially protects against the adverse effects of nitrate/nitrite (Skaggs, Breve & Gilliam, 1994).

Occasional increases in the inorganic nitrogen concentration above the Target Water Quality Range (TWQR) are less important than continuously high concentrations. Figure 3.6 indicates a few peaks but only a slight trend increase could be identified; the anaerobic bacteria and plant growth should further decrease and control the nitrate.

The sharp increase from the control sample point to Flip Human sewage works are due to Mogale City Local Municipality discharging its effluent at the upper reaches of this section. Raw untreated sewage is discharged almost on a continuous basis into the Wonderfonteinpruit. This occurs as a result of poor maintenance of the main sewer alongside the Wonderfonteinpruit, as well as the sewage pump stations at Kagiso. A small stream enters the Wonderfonteinpruit from the east around the centre of this section of the Wonderfonteinpruit. This stream drains a low-cost housing area and transports poor quality surface run-off water (high COD and bacteriological counts) to the Wonderfonteinpruit. The dramatic drop after the Flip Human Sewage Plant is due to dilution of the 23.0 MI/day discharge from the treatment plant.

After sample point 02, there is an increase in nitrate up until the attenuation dam due to the informal settlement located along the Stream. In the literature review, settlements and agricultural activities are major contributing factors of nitrate. Between sample points 3 and 6 the 15 Ml of mine water have a definite dilution effect on the nitrate value. Between the tailings dam and Cooke plant 1, there is a steep increase due to agricultural activities. Mine water from Cooke 1 increase the nitrate again. Due to the inflow of the Cooke 2 sewage, the nitrate value increase again. A slight dilution factor is evident in the Donaldson dam. Nitrate will not become a problematic element, as it will increase the vegetation performance of the current wetland (no SABS guideline exists for nitrate).

3.3.2.6 Alkalinity

Alkalinity is a measure of the acid-neutralising capacity of water and as such, it is also an indication of the base content. Ions which commonly contribute to the alkalinity of water are bicarbonate (HCO_3^-) and carbonate (CO_3^{2-}), and at high pH values, hydroxide (OH^-). Total alkalinity is the sum of these three ions. Other ions, which can also contribute to the alkalinity, are borates, silicates, phosphates and some organic substances (AWWA, 1971).

The geological nature of the rocks and soils in a particular catchment area strongly influences the natural alkaline content of water. Alkalinity of natural water can range from zero to several hundred mg CaCO_3/R . Alkalinity can be neutralised in rivers, dams and ground waters by acid inputs from mining or industrial activities (CCREM, 1987). This is the case where the alkalinity first rises due to the high volume of neutral pH sewage effluent that is added but at sample points MS03 to MS07 the alkalinity started to decrease to lower levels (see *Figure 3.7*). In short, as the salt load increases alkalinity decreases. The Flip Human sewage works lifts the alkalinity with the additional 23 Ml/d and the alkalinity drops as it enters the attenuation dam of the mine indicating that the water stored might have a low pH.

Wonderfontein Spruit Total Alkalinity

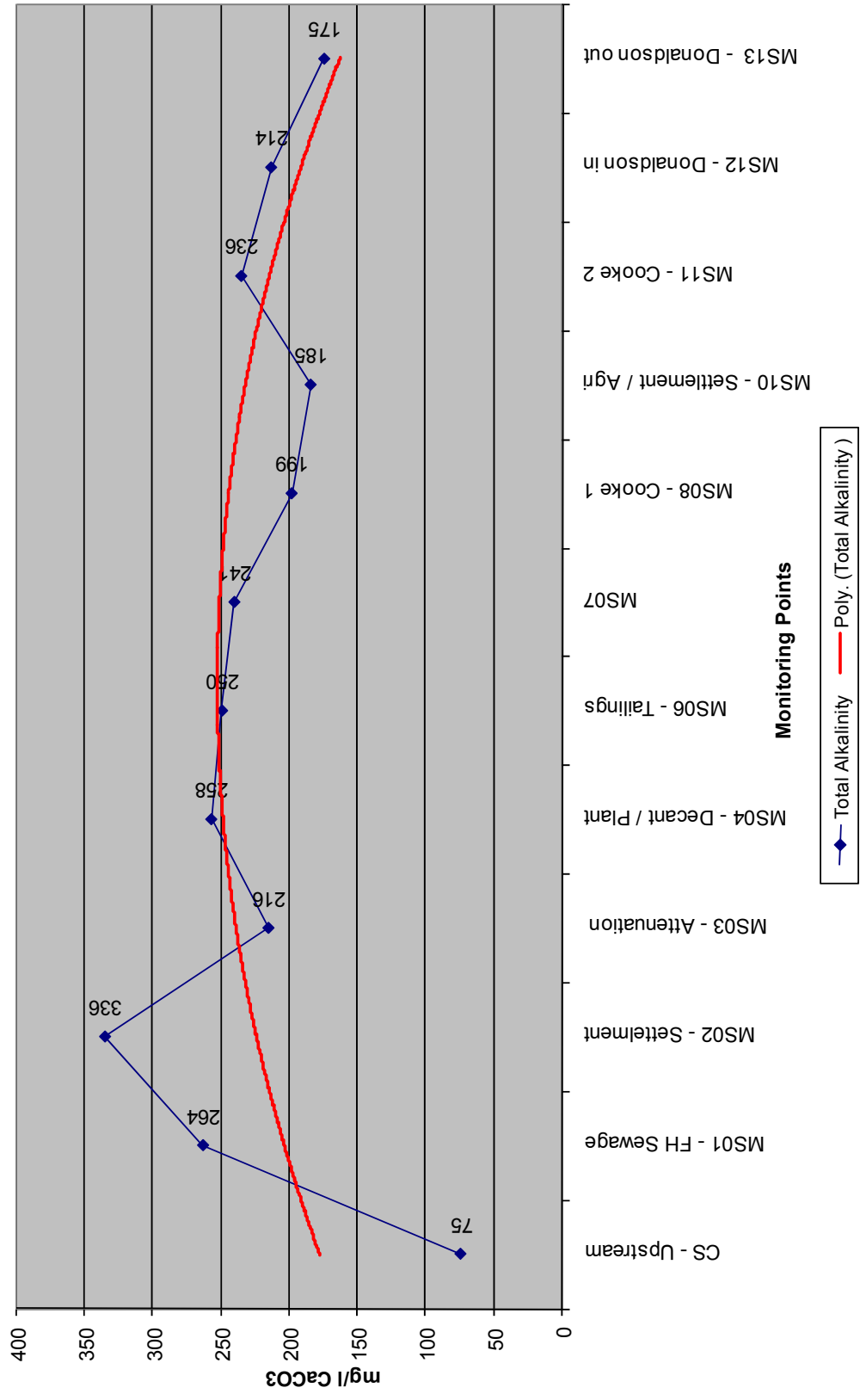

Figure 3.7 ALKALINITY

The 15 MI of pre-treated mine water drops the alkalinity, and it decreases slowly until the Cooke 1 plant. Agriculture and informal settlements contribute to the increase after sample 10, with a dilution factor at the Donaldson dam.

3.3.2.7 Iron

Iron is the fourth most abundant element in the earth's crust and may be present in natural waters in varying quantities depending on the geology of the area and other chemical properties of the water body. The two common states of iron in water are the reduced (ferrous, Fe²⁺) and the oxidised (ferric, Fe³⁺) states. Most iron in oxygenated waters occurs as ferric hydroxide in particulate and colloidal form and as complexes with organic, especially humic, compounds. HUMIC compounds are acidic dark coloured and predominantly aromatic substances that occur in soil organic matter (Förstner, 1981). Although iron has toxic properties at high concentrations, inhibiting various enzymes, it is not easily absorbed through the gastro-intestinal tract of vertebrates. On the basis of iron's limited toxicity and bio-availability, it is classified as a non-critical element.

Iron is naturally released into the environment from weathering of sulphide ores (pyrite, FeS) and igneous, sedimentary and metamorphic rocks. Leaching from sandstones releases two iron oxides and iron hydroxides to the environment. Iron is also released into the environment by human activities, mainly from the burning of coke and coal, acid mine drainage, mineral processing, sewage, landfill leachates and the corrosion of iron and steel.

The amount of iron in solution may be affected by biological interactions. Micro-organisms and fungi in subsurface environments may mobilise the flocculent materials and bring iron into solution. In anaerobic sediments, ferric oxide and hydroxides may be reduced when certain strains of micro-organisms and an organic food source are present (Dallas, Day & Reynolds, 1995).

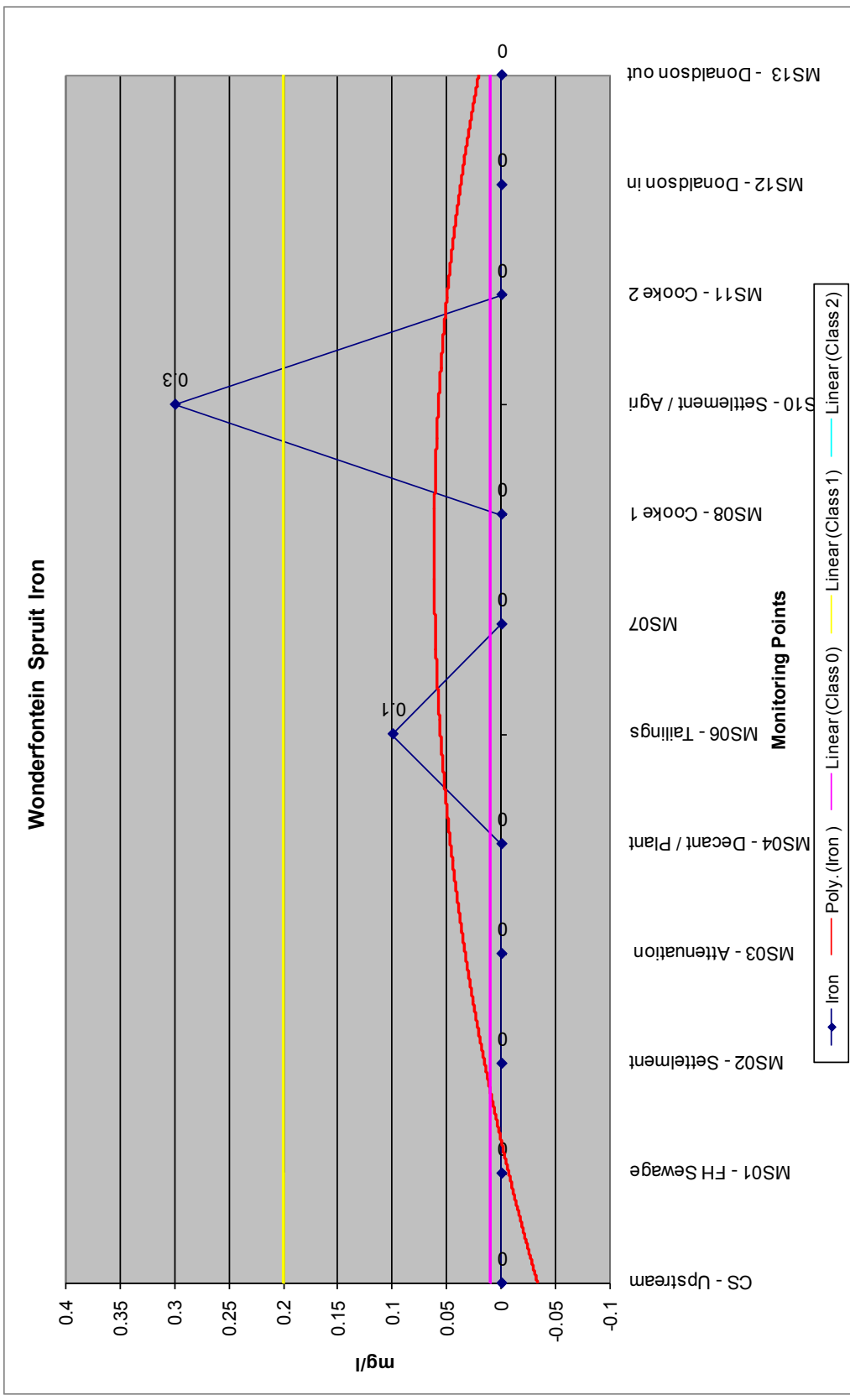

Figure 3.8 IRON

The growth cycles of freshwater algae may influence the concentrations of iron in surface water in particular the demand for iron during algal blooms can significantly reduce iron concentrations. Iron taken up during growth may be released back into the water column upon death and decay of the plants. Flow values gradually decrease in the system and this reduction in flow also has an impact on the iron load in the water. The trend line indicates that even with the 15MI decant water there is a rise in the iron. Two peaks are present in Figure 3.8 at the tailings dam and the other just after Cooke plant 1. The control sample upstream was in the range of a class 0, unfortunately the tailings dam and Cooke plant 1 are the only out of compliance values that degrade the water to a class 2. Iron has to be one of the factors that should be addressed and mitigated.

3.3.2.8 Bacteriological analyses

A means of establishing the performance of the current wetland in removing sulphates from the water is to monitor the presence of Sulphate Reducing Bacteria (SRB's) and Sulphate Oxidising Bacteria (SOB's) and the presence of *Escherichia coli*. The results of samples analysed for sulphate oxidising bacteria (SOB) and *Escherichia coli* are presented in Table 3.3. As a consequence of the high costs associated with testing bacteriological indicators only a selected number of sample points were analysed.

The sulphate processing, bacteriological analyses thus far indicate low counts for SOB's (<10cfu/ml) and SRB's (10 -100cfu/ml). The low count for SOB's may be explained by the relative fast flow rate of the water at the sites sampled. Results for SRB's may have been influenced by the selection of the monitoring sites. Higher counts may be obtained if samples are taken of sediment deeper into the reed beds. The analyses for *Escherichia coli* produced high counts at MS01 and MS08 that correlates with the chemical analyses that indicates external sources being responsible for the increased values. The higher value obtained from MS01 can be attributed to the sewerage effluent originating from the Flip Human sewerage

works. The count at MS08 might be due to the agricultural activities and informal settlements, however, no *E. coli* was present at the last monitoring site (MS13).

Table 3.3 RESULTS OF BACTERIOLOGICAL ANALYSIS

Sample ID	Units	Lab ID					
		CS	MS04	MS07	MS08	MS11	MS13
		1253/1	1254/1	1234/2	1253/2	1253/3	1253/4
SOB (water samples)	Cfu/ml	<10	<10	<10	<10	<10	<10
SOB (soil samples)	Cfu/g	<10	<10	<10	<10	<10	<10
SRB (sediment)	Cfu/g	<10	10-100	10-100	10-100	10-100	10-100
<i>E. coli</i>	Cfu/ 100ml	58	880	0	190	0	0

3.3.2.9 *Biomonitoring*

The macro-invertebrate assemblage gives a good indication of the biological health of an aquatic environment. The macro-invertebrate assessment was done using the SASS5 (South African Scoring System version 5) method. The motivation for SASS sampling in this case study is to use the results as an indication of the macro-invertebrate assemblage along the route of the stream compared to the control site. This would provide an indication of water quality improvement or degradation along the affected area. The macro-invertebrate assessment was done using the SASS5 method at CS (water enters study area), MS06 (middle of study area) and MS12 (water exits study area) (costs of testing is also limited the number of samples analysed). These sites were selected, as they are suitable bio-monitoring habitats on the route that the water follows from north to south in the study area. The SASS results are provided in Table 3.4.

The relative low scores obtained by the SASS survey can be attributed to the long-term biochemical impacts on the aquatic system. These scores are a reflection of the long-term affects of the impacts the stream has been subjected to for many years. This explains the absence of the more sensitive organisms. The “poor” score for MS06 and MS12 is also due to the habitats present. These will exclude organisms depending on better cover objects and oxygen rich water generated by more suitable habitats.

Table 3.4 SASS RESULTS

Site	Habitat description	Score
CS	Diverse marginal vegetation	Fair
	Rock and stone bottom	
MS06	Diverse marginal vegetation	Poor
	Aquatic vegetation, sandy bottom	
MS12	Homogenous phragmites vegetation on margins	Poor
	Artificial bottom of medium sized gravel	

3.4 Water volumes

3.4.1 Volume of water flow

The volume of water flow was measured at strategic sites to assist in calculating the loss or accumulation of water in the system and also the salt load at all the monitoring sites. Due to the fact that an accurate flow-measuring device was not available at the time of this survey, approximate flow values were calculated by measuring the volume of water passing a specific point in a given time. The Manning formula was used to calculate flow at culvers (Walkowiak, 2006):

$$Q = VA \quad V = \frac{k}{n} \left(\frac{A}{P} \right)^{2/3} S^{1/2}$$

The Manning Equation is the most commonly used equation to analyse open channel flows. It is a semi-empirical equation for simulating water flows in channels and culverts where the water is open to the atmosphere, i.e. not flowing under pressure, and was first presented in 1889 by Robert Manning. The channel can be any shape - circular, rectangular, triangular, etc. The units in the Manning equation appear to be inconsistent; however, the value k has hidden units in it to make the equation consistent. The Manning Equation was developed for uniform steady state flow where S is the slope of the energy grade line and $S=h_f/L$ where h_f is energy (head) loss and L is the length of the channel or reach. For uniform steady flows, the energy grade line = the slope of the water surface = the slope of the bottom of the channel. The product A/P is also known as the hydraulic radius, R_h . The following approximate values for water flow were calculated and are presented in Table 3.5.

Table 3.5 APPROXIMATE WATER FLOW IN THE STUDY AREA

	SITES											
	CS	MS 01	MS 02	MS 03	MS 04	MS 06	MS 07	MS 08	MS 10	MS 11	MS 12	MS 13
Approx. flow	120	590	530	120	550	410	415	395	395	300	235	155

3.4.2 Evaporation and evapo-transpiration

The type of vegetation and total area covered was used in calculating water loss through evapo-transpiration in the wetland. The Penman-Monteith (1985) method and variables obtained from Monteith (1985) was used (Monteith, 1985). By defining the reference crop as a hypothetical crop with an assumed height of 0.12 m having a surface resistance of 70 s m^{-1} and an albedo of 0.23, closely

resembling the evaporation of an extension surface of green grass of uniform height, actively growing and adequately watered, the FAO Penman-Monteith method was developed. The method overcomes shortcomings of the previous FAO Penman method and provides values more consistent with actual crop water use data worldwide. From the original Penman-Monteith equation (Equation 3) and the equations of the aerodynamic (Equation 4) and surface resistance (Equation 5), the FAO Penman-Monteith method to estimate ET_o can be derived (Box 6) (see Fig 3.9):

$$ET_o = \frac{0.408\Delta(R_n - G) + \gamma \frac{900}{T + 273} u_2 (e_s - e_a)}{\Delta + \gamma(1 + 0.34u_2)}$$

- Where: ET_o reference evapo-transpiration [mm day^{-1}]
 R_n net radiation at the crop surface [$\text{MJ m}^{-2} \text{day}^{-1}$]
 G soil heat flux density [$\text{MJ m}^{-2} \text{day}^{-1}$]
 T mean daily air temperature at 2 m height [$^{\circ}\text{C}$]
 u_2 wind speed at 2 m height [m s^{-1}]
 e_s saturation vapour pressure [kPa]
 e_a actual vapour pressure [kPa]
 $e_s - e_a$ saturation vapour pressure deficit [kPa]
 Δ slope vapour pressure curve [$\text{kPa } ^{\circ}\text{C}^{-1}$]
 γ psychrometric constant [$\text{kPa } ^{\circ}\text{C}^{-1}$]
(Psychrometric **constant** for different altitudes)

The reference evapo-transpiration, ET_o , provides a standard to which evapo-transpiration can be compared at different periods of the year or in other regions and evapo-transpiration of other crops can be related. Calculations indicate that an annual average of 3.8 ML of water is lost daily through evapo-transpiration (see Table 3.6).

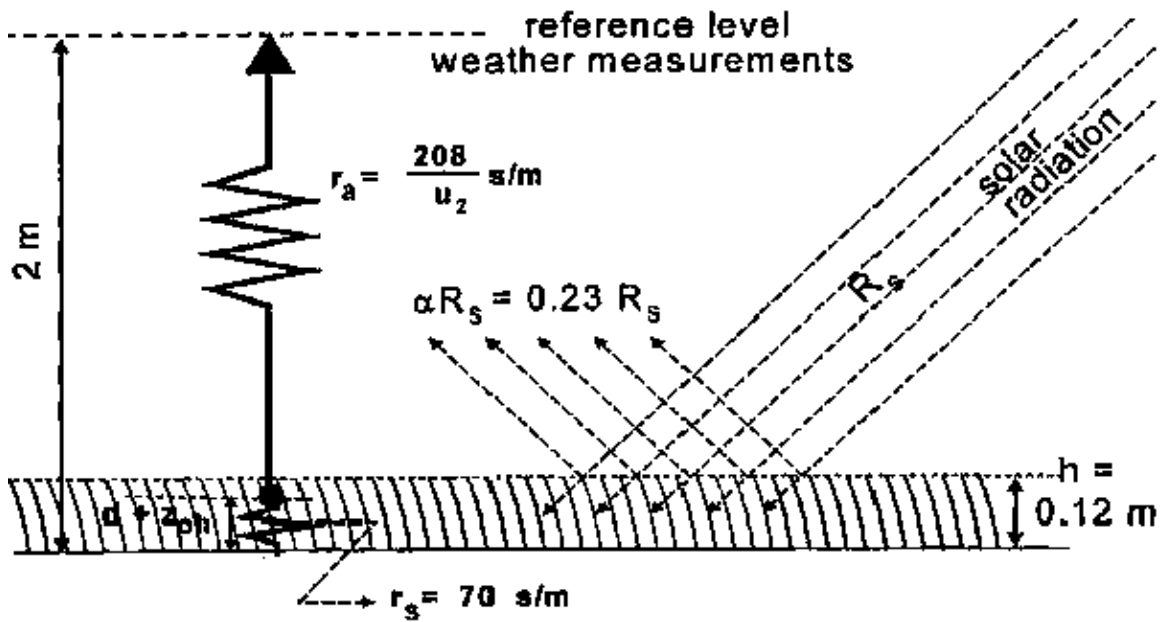

Figure 3.9 PENMAN-MONTEITH EQUATION

Table 3.6 EVAPO-TRANSPARATION

	Area description	Total area	Water loss mm/day	Water loss L/day
Evapo-transpiration	Phragmites reed beds	3652516m ²	4.3mm	1,570,579L/day
Evaporation	Open water dams	407263m ²	5.5mm	2,239,949L/day

3.4.3 Water balance

Water flow is schematically explained in Figure 3.10. Results obtained for water flow and water loss indicates that ± 25.2 MI of water is lost daily through evaporation and evapo-transpiration. Flow values gradually decrease in the system and this reduction in flow also has an impact on the salt load in the water. This is reflected in the conductivity values that steadily increase over the length of the study area.

3.4.4 Vegetation cover

The vegetation report of the study area is best explained by viewing the study area on a north–south axis, starting with the control monitoring site (**CS**) as the northernmost- and monitoring site 13 (**MS13**) as the southernmost points of reference. The vegetation composition of the Wonderfonteinspruit was assessed along this axis following the route of the stream, where possible, using the monitoring sites as points of reference.

Due to the slight incline present at **CS**, the stream channel is well defined and the water is clear. As result of the incline no fanning is present. These features are reflected in the vegetation index, with the obvious absence of aquatic species and the presence of dominantly stream bank and marginal species. Dominant species are: *Persicaria decipiens*, *Limosella longiflora*, *Ranunculus multifolius*, *Rumex crispus* and *Juncus effusus*.

However, the area downstream of **MS01** and including **MS02** consists mainly of aquatic species due to the very low gradient and the absence of a well defined stream channel. The nutrient rich water from the sewerage plant, result in prolific growth of the common reed (*Phragmites australis*) with a height of 2.5-3.0 m being reached. The reed beds cover a wide area of more than 300m in places. The marginal to aquatic species, *Typha capensis* (bulrush), as well as *Plantago longissima*, are also present along the fringes of the waterline. This species is indicative of a permanent high-waterline in this area.

The northern area of the attenuation dam located at the Cooke Metallurgical Plant is also well vegetated with common reeds and bulrush. However, the rest of the dam is devoid of reeds and only marginal vegetation is present, including a large variety of sedges (**MS03**). The dominant species are: *Pycreus nitidus*, *Schoenoplectus brachyceras*, *Cyperus eragrostis* and *Juncus lomatophyllus*. Duckweed (*Spirodela* sp) is also present in the aquatic zone.

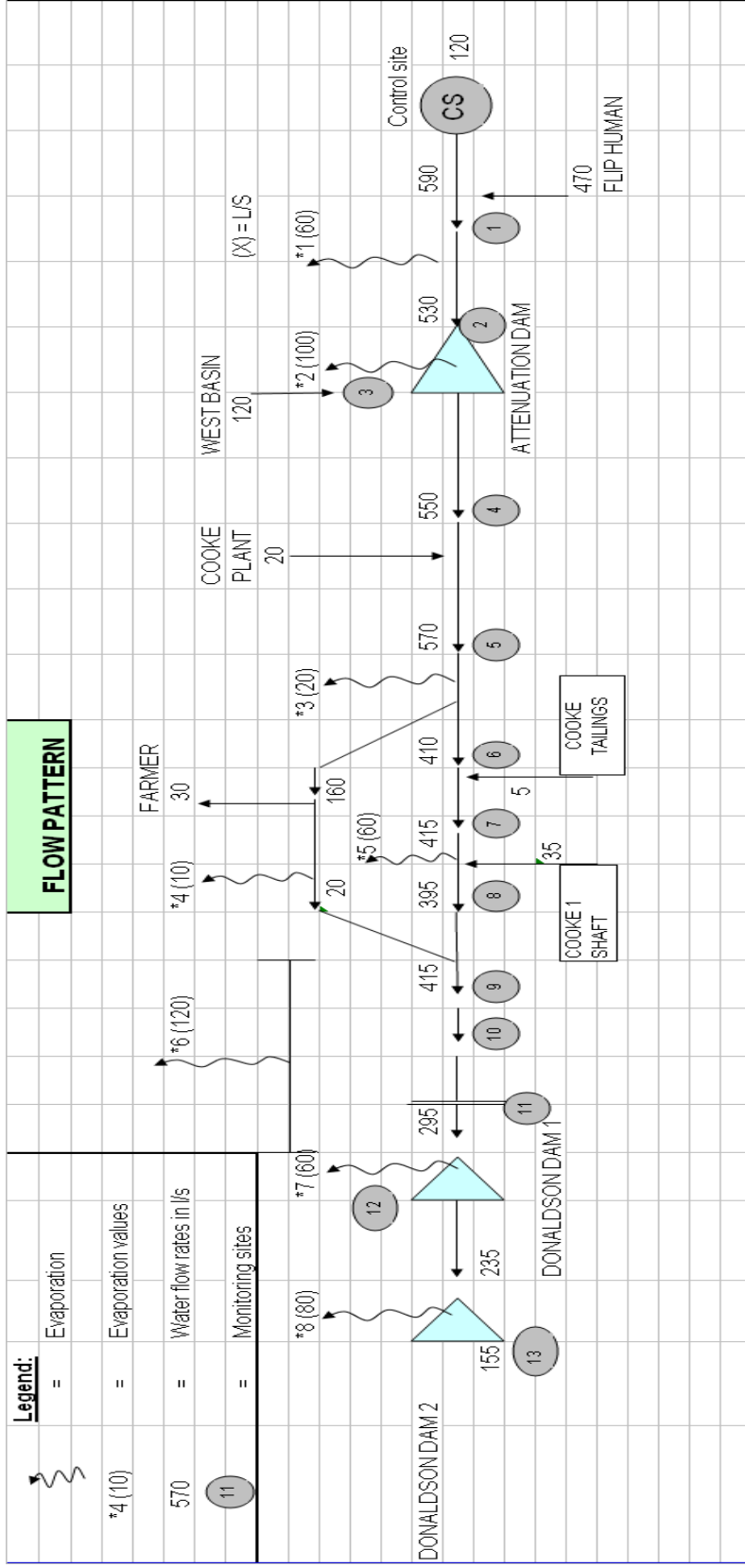

Figure 3.10 WATER FLOW DIAGRAM FOR THE STUDY AREA

The stream channel becomes less defined in the area beneath the dam as the topography becomes flatter and the water fans out on the plain. This area (**MS04** and **MS05** inclusive) consists mainly of common reeds (damp floodplain) and bulrush (margins of floodplain). Water is diverted to an irrigation channel downstream of **MS05**, serving the needs of a nearby farmer. From this point downstream, the stream channel becomes well defined again and the vegetation becomes more marginalised with a variety of species present at **MS06**: *Persicaria decipiens*, *Nasturtium officinale* and *Berula erecta*. The vegetation is marginal with few reeds present, up to and including **MS07** where several species of sedges are present on the margins, as well as the stream banks: *Juncus effuses*, *Schoenoplectus brachyceras*, *Typha capensis* and *Cyperus compressus*.

The vegetation becomes progressively much more dominated by common reeds with few or no bulrush present as the water flow fans out in the area south of **MS07** due to the level topography. This area stretches downstream of **MS07** to the inflow into the Donaldson Dam (including **MS08**, **MS09**, **MS10** and **MS11**). The reed beds are very wide >300m and surface water fans out and as a result is very shallow. The vegetation in the Donaldson Dam consists of common reeds that occur in marginal clusters spread randomly around the margins of the dam (**MS12** and **MS13**).

The total area covered by *Phragmites* and *Typha* reed beds in the study area consists of 3,652516.3 m² (3.6 km²). The average height is 2.8 m and density is ±50 plants/m².

3.5 Impact of additional water

One of the concerns relating to the additional 15 MI that is discharged into the Wonderfontein spruit is the impact it would have on the water level in the stream and the culverts and bridges crossing the stream. The impact of discharge of 15 MI/day into the Wonderfontein spruit, the 100-year return period flood lines were also determined for the study area (Zylstra, 2005). As part of the determining of flood lines, a series of cross-sections are drawn across the stream at regular

intervals and the profile and gradient of the stream plotted. The cross sections used are shown in Figure 3.10. The target flood is then routed through these cross-sections and the elevation that comes closest to the target volume is then recorded.



Figure 3.11 EXAMPLES OF WETLAND VEGETATION COVER

The methods used to design the various storms and to synthesise the resultant direct run-off hydrographs are described and published in Report No. 1/72, 'Design Flood Determination in South Africa', December 1972 and Report No. 1/74 'A Simple Procedure for Synthesising Direct Runoff Hydrographs' by the Hydrological Research Unit (a division of the Department of Civil Engineering at the University of the Witwatersrand). These two reports were produced through a joint venture between the CSIR and the University of the Witwatersrand and are considered to be the only accurate methods for synthesising direct run-off hydrographs under Southern African rainfall conditions.

Zylstra (2005) used these same cross-sections and routed the 15 MI/day through them. The only difference was that we used a dry-weather stream as base, i.e. it was assumed that there would be minimal water in the stream. From

Figure 3.11 (Zylstra, 2005) where the cross sections used in synthesising the 100-year return period flood lines of the Wonderfonteinspruit is shown, it is clear that the stream elevation would not rise a great deal. The maximum elevation difference that will be recorded will be 24 cm. It must be emphasised that the elevation difference is calculated above the normal dry weather flow.

During the wet season, the water level in the Wonderfonteinspruit will rise and flood over a wider surface area. The additional elevation in the stream will therefore diminish as the stream cross-section becomes wider. By the time the stream reaches the 100-year flood width, the additional elevation resulting from the 15 MI/day of mine water will totally insignificant. Compare 15 MI/day, or $0.6944 \text{ m}^3/\text{s}$ with a flow rate of $308.5 \text{ m}^3/\text{s}$ produced by a flood with a 100-year return period (Zylstra, 2005).

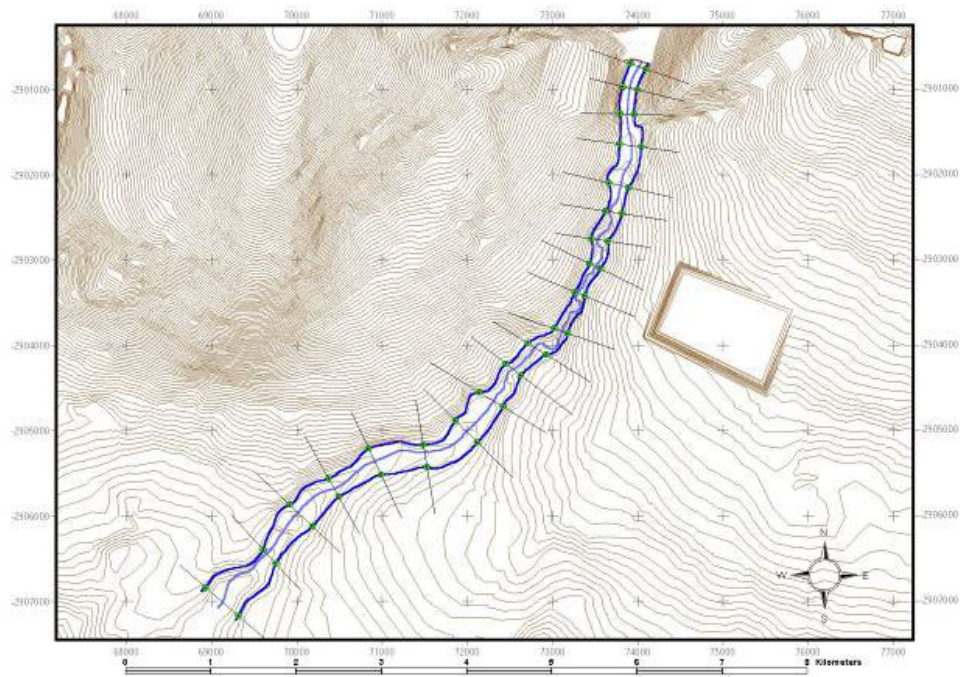

Figure 3.12 CROSS SECTIONS OF WONDERFONTEINSPRUIT

Table 3.7 ELEVATION OF WONDERFONTEINSPRUIT WITH ADDITIONAL WATER

Attenuation Dam to R559 Bridge			
Point	Lowest point in stream	15 MI/6hr = 0.6944 Kl/s	Difference (cm)
1	1609	1609.04	4
2	1608	1608.22	22
3	1608	1608.05	5
4	1607	1607.04	4
5	1604	1604.03	3
6	1602	1602.06	6
7	1599	1599.08	8
8	1597	1597.02	2
9	1596	1596.24	24
10	1594	1594.08	8
Average:			8.6
Max. increase (cm):			24

R559 Bridge to Donaldson Dam			
Point	Lowest point in stream	15 MI/6hr = 0.6944 Kl/s	Difference (cm)
1	1591	1591.22	22
2	1591	1591.05	5
3	1589	1589.15	15
4	1588	1588.03	3
5	1586	1586.05	5
6	1584	1584.05	5
7	1582	1582.04	4
8	1579	1579.07	7
9	1577	1577.04	4
10	1575	1575.08	8
Average:			7.8
Max. increase (cm):			22

3.6 Conclusion

Referring back to Table 3.2 concerning the water analysis, there are four elements that do not comply with the SABS criteria for Class 0 water. Conductivity falls within Class 1 having a maximum of 178 mS/m @25°C it should be reduced to below 70 mS/m. Total dissolved solids have a value of 1585 mg/l much higher than the prescribed 450 mg/l, making it Class 2 water and has to be remediated accordingly. The last two problematic elements are both considered as Class 2 water with sulphate peaks at 592 (823) mg/l where

the preferred value is less than 200 mg/l and iron should be below 0.01 mg/l not the maximum measured 0.3mg/l.

The sulphate processing, bacteriological analyses indicate low counts for SOB's and SRB's. The analyses for *Escherichia coli* produced high counts at two sites of the Wonderfonteinspruit but decreased to 0 at the last monitoring site. The relative low scores obtained by the SASS survey can be attributed to the long-term biochemical impacts on the aquatic system. Calculations indicate that an annual average of 3.8 ML of water is lost daily through evapo-transpiration if the total area covered by *Phragmites* and *Typha* reed beds in the study area of 3,652516.3m² (3.6km²) is taken into account. The maximum elevation difference that will be recorded will be 24 cm with the additional 15 MI of mine water per day. The additional 15 MI of mine water only increases the average elevation of the river water by 24 cm.

Chapter 4

EVALUATION OF REMEDIATION METHODS

The aim and objectives of this study were to provide remediation measures as a result of acid mine drainage and other impacting factors on the water quality and volume in the Wonderfonteinspruit. The main contributors were identified as the decanting water of the dormant mine, the informal settlements next to the Wonderfonteinspruit, the sewage works upstream and adjacent to the stream, some agricultural activities and the tailings dam. After conducting a detailed literature review of the five major impacting factors, an analysis on the impacts on water quality and volume of the Wonderfonteinspruit was done. In this chapter the different mitigation methods for the impacts will be discussed and thereafter the best remediation methods will be identified.

4.1 Impacts identified through the literature review

4.1.1 Acid mine drainage

Problems associated with acid mine drainage are usually high iron concentrations with a very low pH and high sulphate. In this study a pre-treatment plant was in place that chemically adjusts the pH values to acceptable levels and aerates some of the iron out. The impact that needs remediation is sulphates and iron. As was mentioned in Chapter 2, Literature review, there are basically five treatment options for acid mine drainage.

4.1.1.1 Carbonate neutralisation

As was mentioned by Ziemkiewicz *et al.* (1994) in the literature review, they use this technique for a neutralising effect, using limestone chips. Using these chips on site the impact has been much less than anticipated because of the creation of an insoluble calcium sulphate layer on the limestone chips, coating the material and preventing further neutralisation. It is not necessary to use limestone drains in this specific study area of the Wonderfonteinspruit as the mine's primary treatment plant sufficiently increases the pH level of the water

entering the Wonderfonteinspruit. This water varies between 6-9 pH thus is categorised as class 0 drinking water where only the pH is considered.

4.1.1.2 *Ion exchange*

The cost of ion exchange materials compared to the relatively small returns, as well as the inability of current technology to efficiently deal with vast amounts of effluent, has made this unviable, especially if the amount of water to be treated at 15 Ml per day is taken into account.

4.1.1.3 *Active treatment with aeration*

The increase in the pH promotes the oxidation of the iron and the formation of iron hydroxide, which will precipitate out of the solution, leaving little iron left in the water. Large aeration systems can be used to allow more CO₂ to outgas, and thus precipitate more iron out of the solution. This method can only work according to Moshiri (1993) for run-off, which is naturally alkaline as is the pre-treated water of the Wonderfonteinspruit. The primary treatment on the mine premises is largely based on this aeration system, where the iron is precipitated before it enters the Wonderfonteinspruit. It would be prudent to consider combining the constructed wetland with more aeration systems in order to remove the remaining iron and aerate the water to ensure the optimum floral growth and a healthy habitat for all fauna species.

4.1.1.4 *Precipitation of metal*

Enough alkalinity must be added to raise the pH in the water and supply hydroxides (OH⁻) so that dissolved metals in the water can form insoluble metal hydroxides and settle out of the water. The pH required to precipitate most metals from water, ranges from pH 6 to 9 (except ferric iron which precipitates at about pH 3.5). The types and amounts of metals in the water therefore strongly influence the selection of an AMD treatment system.

Again this study has the benefit of a primary constructed treatment plant and settling ponds, where various factors can be controlled such as the amount of aeration and the pH levels, to optimise the precipitation of metals. There is a

danger of releasing alkaline water into the Wonderfonteinspruit that would increase the alkalinity, as biological activity in eutrophic systems from the Flip Human Sewage Works may cause a rise in the pH.

4.1.1.5 Constructed wetlands

The constructed wetlands address the pH and metal problems associated with AMD, with the added benefit of water retention and flood attenuation. The challenge when designing a wetland treatment system is to assemble several elements and size them properly to produce biogeochemical processes that treat the mine drainage to the desired water quality on a consistent basis. Mechanisms of metal retention within wetlands, listed in their order of importance, include:

- Formation and precipitation of metal hydroxides;
- Formation of metal sulphides;
- Organic complexation reactions;
- Exchange with other cations on negatively-charged sites;
- Direct uptake by living plants;
- Other mechanisms include neutralisation by carbonates, attachment to substrate materials, adsorption and exchange of metals onto algal mats, and microbial dissimilatory reduction of Fe hydroxides and sulphate.

The way in which a wetland is constructed ultimately affects how water treatment occurs. Two construction styles currently predominate are: 1) "aerobic" wetlands consisting of *Typha* sp. and other wetland vegetation planted in shallow (<30 cm), relatively impermeable sediments comprised of soil, clay or mine spoil; and 2) "anaerobic" wetlands consisting of *Typha* sp. and other wetland vegetation planted into deep (>30 cm), permeable sediments comprised of soil, peat moss, spent mushroom compost, sawdust, straw/manure, hay bales, or a variety of other organic mixtures. In aerobic wetlands, processes in the shallow surface layer dominate treatment. In anaerobic wetlands, treatment involves major interactions within the substrate.

In general, aerobic wetlands can treat net alkaline water; ALD (anoxic limestone drains) can treat water of low Al, Fe³⁺ and SAPS (successive alkalinity producing systems), while anaerobic wetlands can treat net acidic water with higher Al, Fe³⁺ (see *Figure 4.1*).

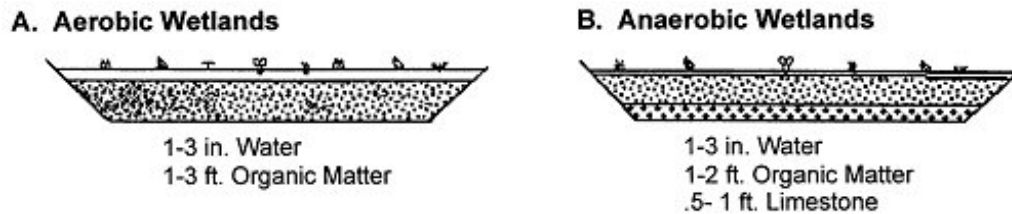

Figure 4.1 CRITERIA FOR AN AEROBIC AND ANAEROBIC WETLAND DESIGN

Relating to this study, it is important to treat both iron and sulphate. It would be best to combine an anaerobic wetland cell with an aerobic cell, because iron needs oxygen to precipitate whereas sulphate can be treated with sulphate reducing bacteria that requires an anaerobic habitat. The water entering the Wonderfonteinpruit will be somewhat acidic and therefore the combined wetland cells should start with an anaerobic cell that will increase the pH and decrease the sulphates.

This cell should be followed by an aerobic wetland designed cell, which will not only oxidise the wetland but also precipitate the iron from the water. This precipitation causes sedimentation with high amounts of metals especially iron. The best way to avoid total wetland degradation is to have sedimentation ponds at the foot of the wetland that must be cleaned out periodically. The last hurdle for the wetland design is the sulphide reducing bacteria. Studies have shown that the best way to decrease sulphate is to use sulphate-reducing bacteria, to activate the bacteria in the wetland and to sustain their activities. Activated sludge or sewage will be pumped into the wetland from Flip Human sewage treatment plant with the necessary permits.

The activity range of Sulphate reducing bacteria *Desulfovibrio desulfuricans* (SRB) are inhibited at pH values lower than 4.5. This would not be a problem as

lime is added to the water before it enters the wetland. The amount of sludge required is 9.556 ml sewage per litre treated, to remove 100 mg sulphate. The use of the activated sludge from the treatment plant will be ongoing, because this sewage removes any oxygen in the system. This allows sulphate to be reduced and also keeps the metals from oxidising. Microbial respiration within the organic substrate reduces sulphates to water and hydrogen sulphide. The one fatal flaw of most wetlands is where the sulphide reducing bacteria could not function well enough as the bacteria used all the available 'compost' in the wetland. Therefore it would be best to continue adding 'compost' in the form of activated sludge. This will ensure the sustainability of the wetland project.

4.1.2 Informal settlements

The major issue with informal settlements is the sanitation problems where wastewater is full of micro-organisms such as *E. coli*, and has a high nutrient content that promotes growth of these organisms that leads to eutrophication of the entire system.

The literature review suggested quite a few remediation methods from Wet on-site or off-site sewer sanitation systems that are adequate for wastewater drainage (10-40 units/hectare). Soak-aways should be constructed (<10 units/hectare). Off-site wastewater drainage (i.e. sanitation) is required where the density of a settlement increases, and where local groundwater or soil conditions reduce local drainage capacity (>40 units/hectare). Care should be taken to develop ecologically sensitive areas and other incidental spaces simultaneously with development of residential areas. Attempts should be made to regulate rapid urbanisation of land along rivers. Land lying along natural drainage channels should be protected and properly developed to maintain and improve water quality.

The best way to solve settlement problems in these areas is to firstly start with an information campaign to educate the people about the risk of using the contaminated river water. The government has a policy to provide the first 6 000 litres of water per household per month free. Issues of basic services like

water, health and shelter are also human rights issues and are guaranteed by the Constitution of the country. More pressure should be placed on the local municipality and government to provide basic sanitary services to the people living in these appalling conditions. The Flip Human sewage works are only 2-3 km from the settlements and connection to the services will be of a minimal cost to the authorities. There is an impact from the settlement's side of the Wonderfonteinspruit due to high values of nitrogen and *E. coli*, but a constructed wetland will benefit from the increased nitrogen and flourish. A decrease can be expected in the *E. coli* count as a result of the wetland as well.

4.1.3 Sewage treatment plants

Wastewater may contain high levels of the nutrients, nitrogen, phosphorus and Faecal coliform. Except for the additional 23 Ml per day of treated water entering the Wonderfonteinspruit, there should not be any impacts on water quality if the treatment plant is up to standard and managed well. However, a definite impact can be seen on the Wonderfonteinspruit regarding the nitrate levels and as stated previously, this can only benefit the flora of the area. All the remediation methods mentioned in the literature review are in place, thus beside from plant maintenance and better management, the only other remediation method applicable to the impact on the water quality will be a wetland. Constructed wetlands include engineered reed-beds and a range of similar methodologies, all of which provide a high degree of aerobic biological improvement and can often be used instead of secondary treatment for small communities.

4.1.4 Tailings dam

There are a number of different metals and contaminants that can leach from a tailings dam. It was not viable for this study to test for all those metals as it has been planned for the near future to reclaim the entire tailings dam, thus solving the metal leaching problem. The two crucial elements that have to be tested for and evaluated are TDS and sulphates:

Total dissolved solids (TDS) are used to indicate the salinity of surface water resources. TDS levels indicate the suitability of water for various

uses such as domestic consumption, agriculture or industrial activities.

High levels are generally related to leaks from these tailing dams.

Sulphate/chloride ratio is used to indicate the influence of mining on increased salinity (for surface waters only).

There is a huge impact on the Wonderfonteinspruit from TDS and sulphates, it is only in the last two decades that the lining of tailings dams became compulsory, therefore the best mitigation methods are to contain the seepage on site and treat or re-use it.

From all the 'barriers' that can be constructed, as was noted in the literature review, the best option for the specific tailings dam would be the a combination of a cut-off trench between the tailings dam wall where the gradient leads the contaminants to the river with a sump and pumpback system to the tailings dam. These systems are widely installed after the construction of the impoundment as a remedial action to collect unanticipated seepage. This option will minimise down gradient seepage, but the pumpback system may continue indefinitely and a good water-quality monitoring program will be beneficial to the water quality of the area.

4.1.5 Agricultural activities

Water logging, desertification, salinisation and erosion can be expected from agricultural activities that cause problems downstream like degradation of the water quality by salts, agrochemicals and toxic leachates. Nitrogen and *E. coli* are also major factors in agriculture. Although the literature review has provided very complicated solutions, the best would be an education programme with the Department of Agriculture. If one takes into account the total area under agriculture, it is not worthwhile spending too much time and finances on this impact. There is a vast amount of literature on reed-bed or constructed wetland and agricultural wastewater being treated by wetlands, bringing the quality of the water to drinkable standards.

4.1.5 Best remediation option

In this chapter alternative mitigation methods for the impacts of the five major contaminants has been examined and it all comes down to constructed wetlands. It is, however, not a straightforward solution therefore a lot of work needs to be done on a specific design to accommodate all the different pollutants and water quality ranges. The basic design will be an anaerobic cell, directly followed by an aerobic cell with a sedimentation pond that will accumulate all the contaminated sludge for disposal on the tailings dam (as per mining license) (see *Figure 4.2* for a schematic representation of the planned wetland).

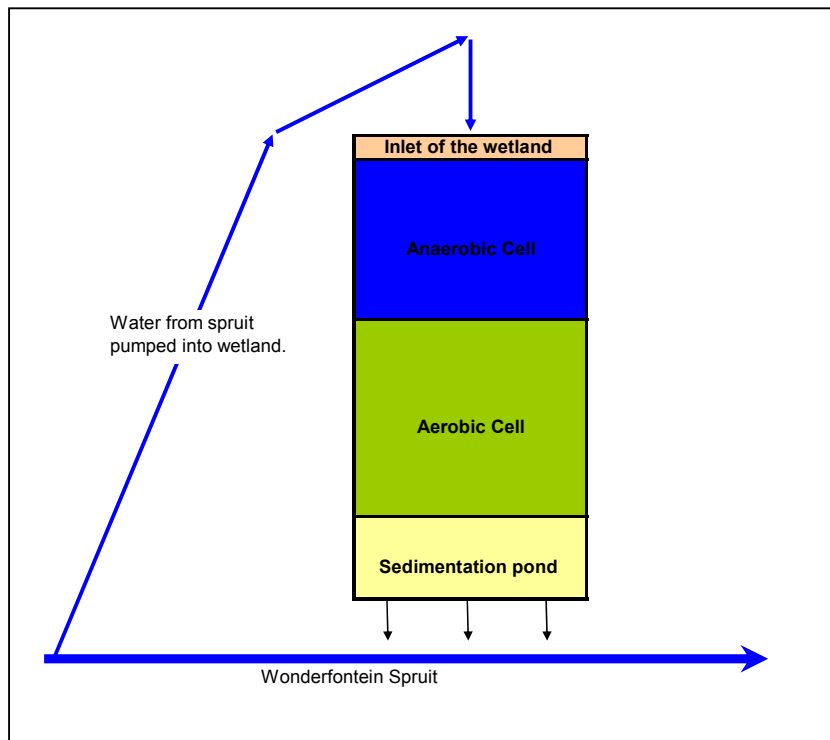

Figure 4.2 SIMPLISTIC VIEW OF THE PLANNED WETLAND

4.3 Conclusion

By weighing up the different remediation options, the best way to solve the Wonderfonteinspruit water quality and volume issue would be by means of a constructed wetland system and a pump back system where the tailing dam leach into the groundwater flowing to the Wonderfonteinspruit.

Chapter 5

RECOMMENDATION OF APPROPRIATE MITIGATION METHODS

This chapter will address mitigation methods for the problematic elements identified in previous chapters. These problematic elements include conductivity, total dissolved solids, sulphate and iron that degrade the water quality. As for the water volume, some retention and decrease in flow is considered necessary. The water quality and volume requirements include:

- Conductivity of 178 mS/m @25°C reduce to 70 mS/m;
- Total dissolved solids of 1585 mg/l reduce to 450 mg/l;
- Sulphate of 592 mg/l reduce to 200 mg/l;
- Iron of 0.3mg/l reduce to 0.01 mg/l;
- Water retention and decrease of flow.

Based on the literature review (Chapter 2), the best alternative to improve the Wonderfonteinspruit's water quality and volumes were identified and discussed in Chapter 4. It was clear that a combined and well-designed wetland would be the best option for this specific study. Figure 5.1 is a simplistic diagram of how a wetland functions (Kotze, 2004).

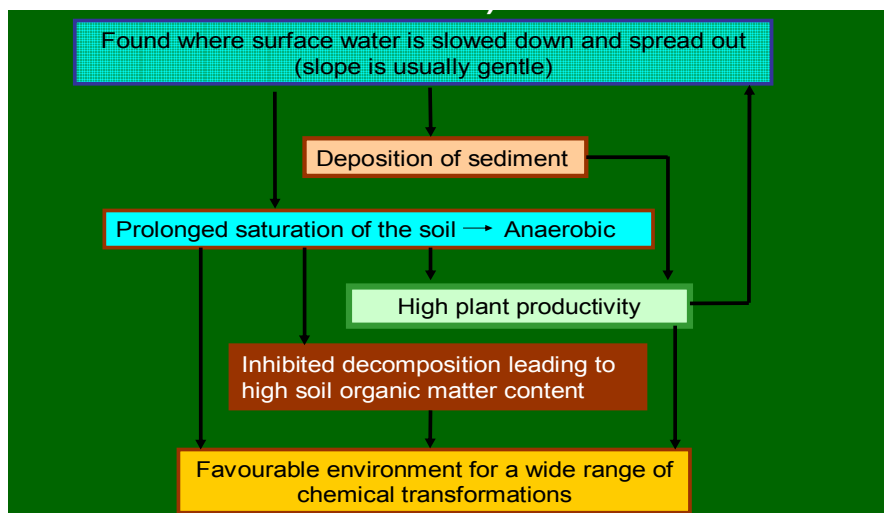

Figure 5.1 DIAGRAM OF HOW A WETLAND WORKS

5.1 Wetland capability

5.1.1 Combined wetlands

A combination of two factors is however required to completely remove iron and sulphate, namely aerated and un-aerated conditions. Iron precipitates in contact with aerated water whereas sulphate will effectively be removed with the help of sulphate reducing bacteria that in turn need un-aerated water conditions. Therefore it is crucial to combine shallow and deep wetland cells. The following table (see *Table 5.1*) shows the benefits of both aerobic and anaerobic wetland systems (Hedin, 1994).

Table 5.1 ECOSYSTEM SERVICES SUPPLIED BY WETLANDS

Aerobic	Anaerobic
Emphasise oxidation reaction	Emphasise reduction reaction
Surface flow of water	Sub-surface flow of water
Oxide precipitates	Sulphide precipitates
Process can lower pH	Process can raise pH
Operate best at pH>5.5	Can operate at pH<5.5
Remove Mn, Se, As and WAD CN and Fe	Remove other heavy metals well and sulphides
Shallow system	Deeper system – to maintain anaerobic conditions
Fe, Al, Mn, As, CN, Hg chemistry changed	Removal of Fe, Cu, Pd, Zn, Hg, Cd, Al, So ₄
From 2-11 g of Fe removed per day per m ² of area	Remove 0,3 moles of metal loading per m ³ of wetland

5.1.2 Aerobic wetland

An aerobic wetland (iron reduction) consists of a large surface area pond with horizontal surface flow. The pond may be planted with cattails and other wetland species. Aerobic wetlands can only effectively treat water that is not alkaline. In aerobic wetland systems, metals are precipitated through oxidation reactions to form oxides and hydroxides. This process is more efficient when the influent pH is greater than 5.5. Aeration prior to the wetland, via riffles and

falls, increases the efficiency of the oxidation process and therefore the precipitation process. Iron concentrations are efficiently reduced in this system but the pH is further lowered by the oxidation reactions.

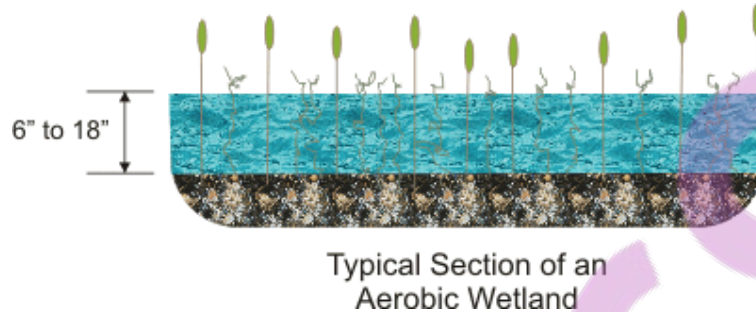

Figure 5.2 AEROBIC WETLAND (Heller & Hedin, 1992)

A typical aerobic wetland will have water depth of 6 to 18 inches (see *Figure 5.2*). Variations in water depth within the wetland cell may be beneficial for performance and longevity. Shallow water zones oxygenation and oxidising reactions and precipitation.

5.1.3 Anaerobic wetlands

Anaerobic wetlands (sulphate reduction) consist of a large pond with a lower layer of organic substrate. The flow is horizontal within the substrate layer of the basin. Piling the compost a little higher than the free water surface can encourage the flow within the substrate. Typically, the compost layer is made from spent mushroom compost that contains about 10% calcium carbonate. Other compost materials include peat moss, wood chips, sawdust or hay.

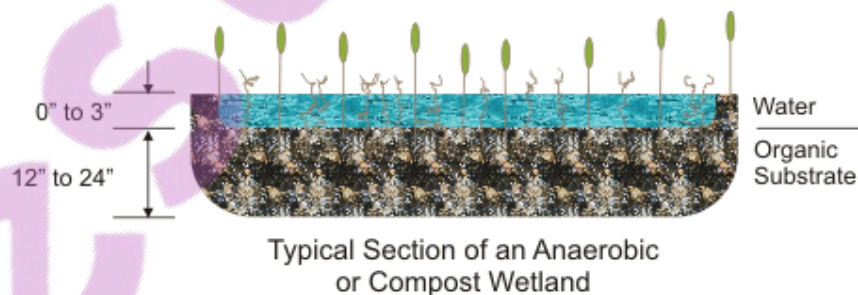

Figure 5.3 ANAEROBIC WETLAND (Heller & Hedin, 1992)

A typical compost wetland will have 12 to 24 inches of organic substrate and be planted with cattails or other emergent vegetation (see *Figure 5.3*). The vegetation helps stabilise the substrate and provides additional organic materials to perpetuate the sulphate reduction reactions (Faulkner & Skousen, 1994).

Anaerobic wetlands are used to treat AMD from active mine discharges to meet established effluent requirements. Generally, the design of these wetlands is conservative and can treat discharges that contain dissolved oxygen, Fe^{3+} , Al^{3+} or acidity less than 300 mg/l. When treating discharges from abandoned mines the goal is to reduce the pollution to levels that will restore the receiving stream.

The compost wetland acts as a reducing wetland where the organic substrate promotes chemical and microbial processes that generate alkalinity and increase the pH. The compost removes any oxygen in the system. This allows sulphate to be reduced. Microbial respiration within the organic substrate reduces sulphates to water and hydrogen sulphide (Hedin, 1992). *Figure 5.4* will help to better understand the wetland microbe habitat diversification through hydrophytes and water depths that make anaerobic conditions possible for sulphate reducing bacteria.

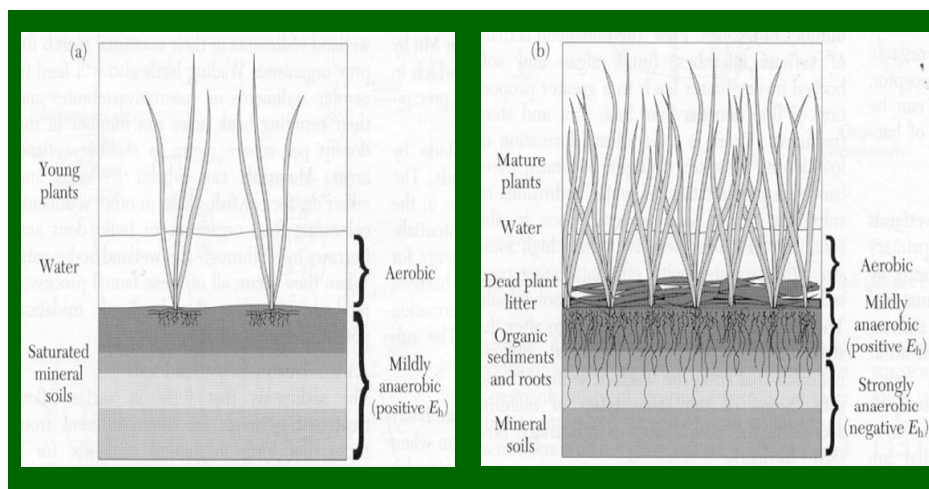

Figure 5.4 WETLAND MICROBE HABITAT DIVERSIFICATION VIA HYDROPHYTES (Sather & Smith, 1984)

5.2 Chemical remediation

5.2.1 Iron removal

A lot of wetland systems fail after a few months due to insufficient utilisation of the treatment area, inadequate alkalinity production and metal overloading (Hellier & Hedin, 1992). In the Wonderfonteinspruit the pre-treatment of the effluent increase the pH and alkalinity of the effluent to acceptable standards

There are basically two designs calculations to be used in iron removing aerated wetlands, US Bureau of mines and Tarutis criteria. A simple example should suffice to demonstrate why the US Bureau of Mines criteria (Hedin *et al.*, 1994) provide a more sensible basis for design than those proposed by Tarutis *et al.* (1999): The construction of the Coal Authority's Edmondsley wetland (County Durham, UK) was completed in the summer of 1999. The Edmondsley mine water flows from an old coal-drift at a rate of about 10 l.s⁻¹, and contains some 30 mg.l⁻¹ of Fe.

The designers of the wetland used the Hedin *et al.* (1994) criteria to estimate the minimum wetland area required, obtaining a value of 2505 m². Fortunately, there was more than twice as much suitable land area available for purchase at the site. Hence, the system was constructed as four aerobic reed-bed cells in series, totalling 4000 m² in area. This design allowed one or two of the cells to be taken out of operation at any time for maintenance purposes without compromising the treatment ability of the system as a whole.

Monitoring of the system since it was commissioned has shown performance in line with expectations, with virtually all of the Fe (down to a residual <0.5 mg.l⁻¹) being removed in the first two cells (i.e. the first 2000 m² of wetland). By contrast, if the wetland had been designed using the first-order model proposed by Tarutis, Stark and Williams (1999), the predicted area of wetland required would have nearly 2 ha. Had the latter design figure been used, the cost of acquiring 2 ha of land in this scenic area would have precluded wetland treatment as a serious option. An active treatment system would have been developed, with huge cost implications for long-term operation.

The US Bureau of Mines criteria (Hedin *et al.*, 1994) remain the most valid design rules currently available, and can be summarised as follows. The basic expression, which must be evaluated, is the following:

$$A = \frac{Q_d (C_i - C_t)}{R_A}$$

Where: A is the wetland area required (m²),
 Q_d is the design flow rate (m³-d-1),
 C_i is the influent Fe concentration (mg-l-1)
 C_t the 'target effluent concentration' (i.e. the desired concentration of the pollutant at the downstream exit point of the wetland in mg-l-1; a value of 0.5 mg-l-1 is typically assumed for Fe)
 R_A is 'a really-adjusted removal rate' for the pollutant of interest (g-d-1-m-2).

For Fe in aerobic reed-beds, RA is recommended to take a value of 10 g-d-1-m-2; for Mn removal in such systems a much lower value of 0.5 g-d-1-m-2 is recommended.

For compost wetlands, usual practice is to define C_i, C_t and RA in terms of total acidity concentrations (in mg-l-1 as CaCO₃ equivalent), with a RA value of 3.5 g-d-1-m-2 total acidity being recommended. An analogous RA value for total acidity removal in a RAPS with a minimum of 0.5 m of compost over 0.5 m of limestone gravel is estimated to lie around 40 g-d-1-m-2 (Watzlaf, Schroeder & Kairies, 2000). For iron removal in this study the compost wetland RA value will not be used as an aerated cell will be used with a neutral pH to decrease the iron value in the Wonderfonteinspruit.

The calculations to work out the required wetland size indicated that it would be necessary to construct a 412 m² for the first wetland to ensure effectiveness this entire area will be used even though only 70% of the Wonderfonteinspruit will be diverted and the flow in the calculation is supposed to be reduced to only

70% of the original. The first wetland should be 450 m² to incorporate a further 10% buffer capacity. The second wetland planned just downstream of the tailings dam should also have a further 10% capacity, so an estimated 1100 m².

Wetland 1 – Calculation

Flow – 530l/s
 Current iron concentration – 0.1mg/l
 Iron concentration limit – 0.01mg/l

530l/s ---- m³/d
 0.53 ----- m³/s
 45 792 m³/d

$$\text{Area} = \frac{45\,792 (0.1 - 0.01)}{10}$$

$$\text{Area} = 412 \text{ m}^2$$

Thus 412 m² of aerated wetland is needed to reduce the iron concentration from 0.1mg/l to 0.01 mg/l as to the SABS criteria

Wetland 2 – Calculation

Flow – 395l/s
 Current iron concentration – 0.3mg/l
 Iron concentration limit – 0.01mg/l

395l/s ---- m³/d
 0.39 ----- m³/s
 33 696 m³/d

$$\text{Area} = \frac{33\,696 (0.3 - 0.01)}{10}$$

$$\text{Area} = 988 \text{ m}^2$$

Thus 988 m² of aerated wetland is needed to reduce the iron concentration from 0.3mg/l to 0.01 mg/l as to the SABS criteria

It is important to have the right design with settling ponds and well-adapted vegetation to best remediate the water. Settling ponds (see 5.3) will prevent the oxidised iron from reaching the river, and the contaminated sediments can be flushed out at regular intervals but will be contained in the settling ponds, where the mine can clean out the pond and take the sludge for appropriate disposal.

5.2.2 Sulphates reduction

Traditional active treatment processes to reduce sulphates such as reverse osmosis or the addition of chemicals employed are often not very efficient and can be quite costly. In some cases they are simply not feasible, therefore alternative methods have to be considered. Studies have shown that the best alternative way to decrease sulphate is to use sulphate-reducing bacteria: *Desulfovibrio desulfuricans*.

Typically, mine drainage contains >500 mg/l of sulphates, and these can be removed from it by reduction to sulphides, by biological uptake, and/or by the formation of organic esters on plant decomposition in a vegetated wetland cell

(biosorption). In the Wonderfonteinspruit study the mine effluent contains 592 mg/l of sulphate and should be reduced to below 200 mg/l. Sulphate reduction is carried out by anaerobic sulphate-reducing bacteria. SRB need sources of organic carbon (for biomass) and sulphates as electron acceptors for their metabolism. There are a large number of species of sulphate-reducing bacteria and their distribution is ubiquitous. Generally, SRB do not grow well at pH values below 5.5 and prefer higher levels of alkalinity, with 6.6 being optimal (Govind, Yong & Tabak, 1999). Therefore, a treatment system, such as a CW, should include a process step in which the pH of the mine drainage is first raised (e.g. passing it through an upstream oxic limestone drain). In the case of the Wonderfonteinspruit there is a pre-treatment plant where the pH are adjusted to acceptable levels for the bacteria. The basic equations for SRB-mediated sulphate reduction can be represented by:

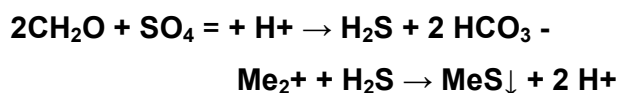

Where CH₂O represents a carbon source and Me is typically a dissolved divalent metal cation.

The hydrogen sulphide quickly reacts with any dissolved cationic metals in the water (e.g., Zn, Cd, Ni) and this results in the precipitation of relatively insoluble metal sulphides. It is noted that two moles of alkalinity and one mole of acidity are the net result of reactions 1 and 2, so the action of the SRB is to raise alkalinity and buffer the solution.

Anaerobic cells using SRB represent a rapidly developing new method for removing contaminants such as sulphates and dissolved metals. They work by passing it through a wetland cell under oxygen-free conditions made of an organic substrate which itself serves as the carbon source. The carbon source can be any type of carbon material (e.g. sawdust, manure), the decaying roots/detritus of the wetland plants, an added soluble carbon-based liquid material (e.g. methanol) (Hard *et al.*, 1997), or a layer of carbonaceous substrate material such as municipal compost or biosolids.

Sulphate-reducing bacteria are sensitive to temperature, and reaction rates are lower where colder water is involved. However, unlike the eukaryotic algae used for the biosorption of dissolved metals in some treatment processes, SRB are prokaryotes and are less affected by cold water. Bacterial communities in ecosystems usually include a number different species of SRB, some of which are cold-adapted and can thrive down to temperatures as low as 4°C, with increased numbers of bacteria compensating for lower reaction rates at these temperatures (Fortin *et al.*, 2000).

Depletion of organic carbon in anaerobic wetland cells creates a tendency for decreased performance with time. Laboratory and pilot tests of carbon sources, replaceable organic matter cartridges and continuous liquid carbon source addition are strategies used to address this problem.

To activate the bacteria in the wetland and to sustain their activities, activated sludge or sewage will be pumped into the wetland from the Flip Human Sewage works with the necessary permitting from the authorities. Continual monitoring will take place on the efficiency and effectiveness of the sulphate reducing bacteria, to recharge the carbon source from the sewage works should the need arise, thus avoiding depletion and dieback of the bacteria.

The activity range of sulphate reducing bacteria *Desulfovibrio desulfuricans* (SRB) are inhibited at pH values lower than 4.5, this would not be a problem as lime is added to the water before it enters the wetland. The amount of sludge required is 9.5 ml sewage per litre treated, to remove 100 mg sulphate (Fortin *et al.*, 2000).

The anaerobic wetland cells should be the same size as calculated as for the aerated cells with an inflow of 1.7 Ml/d of activated sludge from the Flip Human sewage works. In conclusion because the water is pre-treated and has a relatively high pH, the lifetime and effectiveness of the constructed wetland will be more effective and prolonged. It is also important to have the right design with settling ponds and well-adapted vegetation to best clarify the water.

Wetland – Calculation

Flow – 530l/s
Peak Sulphate concentration – 592 mg/l
Sulphate concentration limit – 200 mg/l

530l/s ---- m³/d
0.53 ----- m³/s
45 792 m³/d

$$\frac{\text{m}^3}{\text{d}} \frac{(592\,000 - 200\,000)}{\text{m}^3}$$

45 792 (592 000 – 200 000)

1.79504 x 10¹⁰ (mg/d)
17950464 (g/d)
170529 x 10⁹
1.7 MI/d

Thus 1.7 MI/d of activates sludge is needed to ensure a continuous carbon source for the sulphate reducing bacteria in the anaerobic wetland cells.

5.2.3 Nitrogen removal

Wetlands generally are well suited for N removal. Substantial removal of N may take place through settling of N-containing particulate matter in the wetland inflow. In addition, since N is an essential plant nutrient, it can be removed through plant uptake of ammonium or nitrate, and stored in organic form in wetland vegetation. A large portion of this N may later be released and recycled, as plants die and decompose. Ammonium may be chemically bound in the soil on a short-term basis, while organic N from dead plant material can accumulate in the soil as peat, a long-term storage mechanism.

Nitrate removal efficiency typically is extremely high in wetlands. The biological process of denitrification, i.e. conversion of nitrate to nitrogen gas, provides a means for complete removal of inorganic N from wetlands, as opposed to storage within the vegetation or soil (Reddy & Patrick, 1984). Dynamics and transformations of nitrogen in an ecosystem are illustrated in Figure 5.5. Nutrient cycling from one form to another occurs with changes in nutrient inputs as well as temperature and oxygen availability (Reddy & Patrick, 1984).

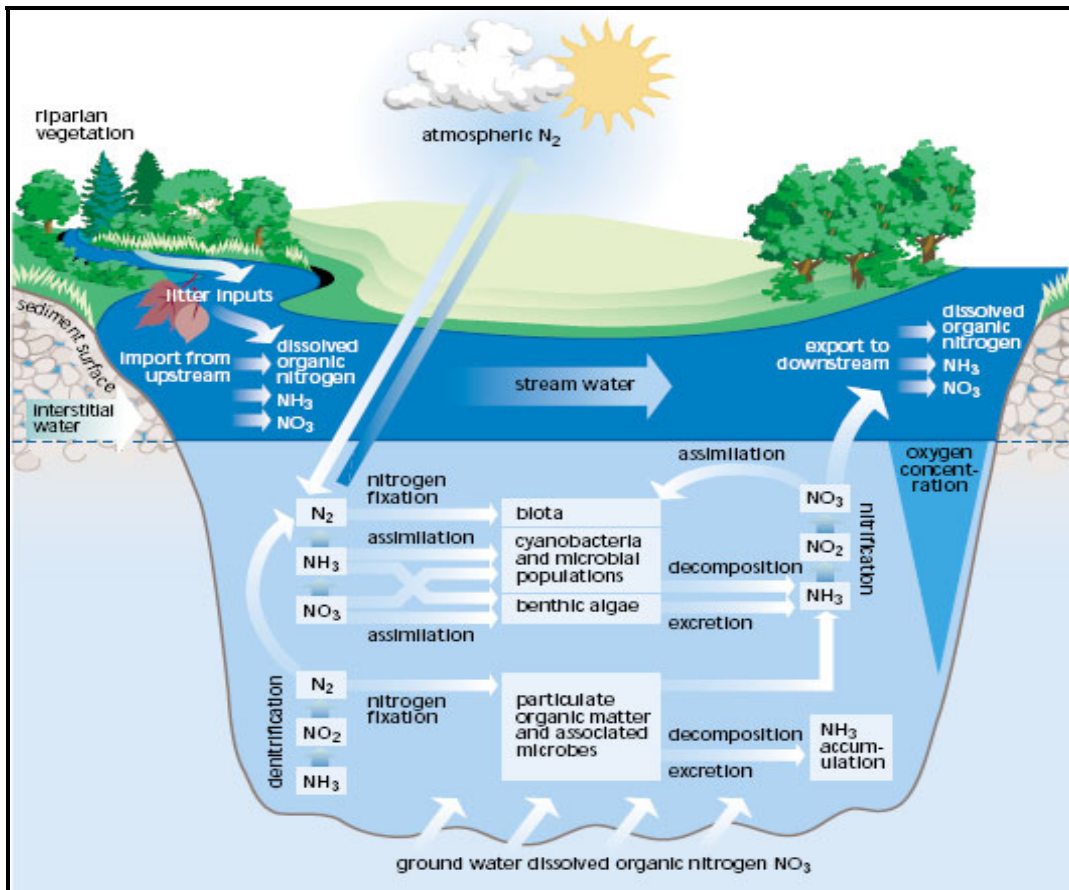

Figure 5.5 DYNAMICS OF NITROGEN (Reddy & Patrick, 1984).

5.3 Wetland design

5.3.1 Design considerations

Design criteria relate directly to the wetland characteristics necessary to provide specific functions. They can be divided into four categories - biologic, hydrologic, geotechnical, and engineering design - although there is considerable overlap between categories and related wetland functions. For convenience, the criteria may be characterised based upon their primary influence on the wetland system. Table 5.2 illustrates all the different criteria a constructed wetland can improve and the ecosystem services wetlands deliver.

Table 5.2 ECOSYSTEM SERVICES DELIVERED BY WETLANDS
(Sather & Smith, 1984)

Ecosystem services supplied by wetlands	Indirect benefits	Hydro-geochemical benefits	Flood attenuation	
			Streamflow regulation	
		Water quality enhancement benefits	Sediment trapping	
			Phosphate assimilation	
			Nitrate assimilation	
			Toxicant assimilation	
		Erosion control		
	Carbon storage			
	Biodiversity maintenance			
	Direct benefits	Provision of water for human use		
		Provision of harvestable resources		
		Provision of cultivated foods		
		Cultural significance		
		Tourism and recreation		
Education and research				

Specific designs may vary considerably, depending on site constraints or preferences of the designer or community. There are some features, however, that should be incorporated into most wetland designs. These design features can be divided into five basic categories: Pre-treatment, treatment, conveyance, maintenance/reduction, and landscaping.

5.3.1.1 Pre-treatment

Pre-treatment is used to settle out coarse sediment particles prior to entry in the main wetland cell. By removing sediments before they reach the wetland, the maintenance burden of the wetland is reduced. In wetlands, Pre-treatment is achieved with a sediment fore-bay. A sediment fore-bay is a small pool (typically about 10% of the volume of the permanent pool). Coarse particles remain trapped in the fore-bay, and maintenance is performed on this smaller pool, eliminating the need to dredge or clean out sediments from the entire wetland (DME, 2000).

5.3.1.2 Treatment

Treatment design features help enhance the ability of a wetland to remove pollutants. Several features can enhance the ability of wetlands to remove pollutants from effluent. The purpose of most of these features is to increase the amount of time and flow-path that water remains in the wetland. Some typical design features include:

- The surface area of wetlands should be at least 1% of the drainage area to the practice.
- Wetlands should have a length to width ratio of at least 1.5:1. Making the wetland longer than it is wide helps prevent "short circuiting" of the practice.
- Effective wetland design "complex micro-topography". In other words, wetlands should have zones of both very shallow (<6") and moderately shallow (<18") wetlands are incorporated, using underwater earth berms (almost like a contour ground wall to direct water) to create the zones. This design will provide a longer flow path through the wetland to encourage settling, and provides two depth zones to encourage plant diversity.

5.3.1.3 Conveyance

Conveyance of water into and through a wetland is a critical component of any water design. Water should be conveyed to and from practices safely and to minimise erosion potential. The outfall of pond systems should always be stabilised to prevent scour. In addition, an emergency spillway should be provided to safely convey large flood events. In order to prevent warming at the outlet channel, designers should provide shade around the channel at the wetlands outlet (DME, 2000).

5.3.1.4 Maintenance reduction

In addition to regular maintenance activities, several design features can be incorporated to ease the maintenance burden of wetlands. One potential maintenance concern in wetlands is clogging of the outlet. Wetlands should be designed with a non-clogging outlet such as a reverse-slope pipe, or a weir outlet with a trash rack. A reverse slope pipe draws from below the micro-pool

extending in a reverse angle up to the riser and establishes the water elevation of the micro-pool.

Because these outlets draw water from below the level of the micro-pool, they are less likely to be clogged by floating debris. Another general rule is that no orifice should be less than 3" in diameter (smaller orifices are generally more susceptible to clogging, without specific design considerations to reduce this problem) (DME, 2000).

Wetlands should incorporate design features that make sediment cleanouts of both the fore-bay and the shallow pool easier. Wetlands should have direct maintenance access to the fore-bay, to allow this relatively routine (five to seven years) sediment cleanouts. In addition, the shallow pool should generally have a drain to draw down the wetland for the more infrequent dredging of the main cell of the wetland.

5.3.1.5 Landscaping

Landscaping of wetlands can make them an asset to a community, and can also enhance their pollutant removal. To ensure the establishment and survival of wetland plants, a landscaping plan should provide detailed information about the plants selected, when they will be planted, and a strategy for maintaining them. The plan should detail wetland plant species, as well as vegetation to be established adjacent to the wetland (DME, 2000).

When developing a plan for wetland planting, care needs to be taken to ensure that plants are established in the proper depth and within the planting season. This season varies regionally, and is generally between two and three months long in the spring to early summer.

5.3.2 Maintenance considerations

Several regular maintenance and inspection practices are needed for wetlands as outlined in Table 5.3 to follow.

Table 5.3 REGULAR MAINTENANCE ACTIVITIES FOR WETLANDS
(CWP, 1998)

Activity	Schedule
Replace wetland vegetation to maintain at least 50% surface area coverage in wetland plants after the second growing season.	One-time (after construction)
Inspect for invasive vegetation and remove where possible.	Semi-annual inspection
<p>Inspect for damage to the embankment and inlet/outlet structures. Repair as necessary.</p> <p>Note signs of hydrocarbon build-up, and deal with appropriately.</p> <p>Monitor for sediment accumulation in the facility and fore-bay.</p> <p>Examine to ensure that inlet and outlet devices are free of debris and operational.</p>	Annual inspection
Repair undercut or eroded areas.	As needed maintenance
<p>Clean and remove debris from inlet and outlet structures</p> <p>Mow side slopes.</p>	Frequent (3-4 times/year) maintenance
<p>Supplement wetland plants if a significant portion have not established (at least 50% of the surface area).</p> <p>Harvest wetland plants that have been "choked out" by sediment build-up.</p>	Annual Maintenance (if needed)
Removal of sediment from the fore-bay.	5 to 7 year maintenance
Monitor sediment accumulations, and remove sediment when the pool volume has become reduced significantly, plants are "choked" with sediment, or the wetland becomes eutrophic.	20 to 50 year maintenance

5.4 Site specific wetland requirements

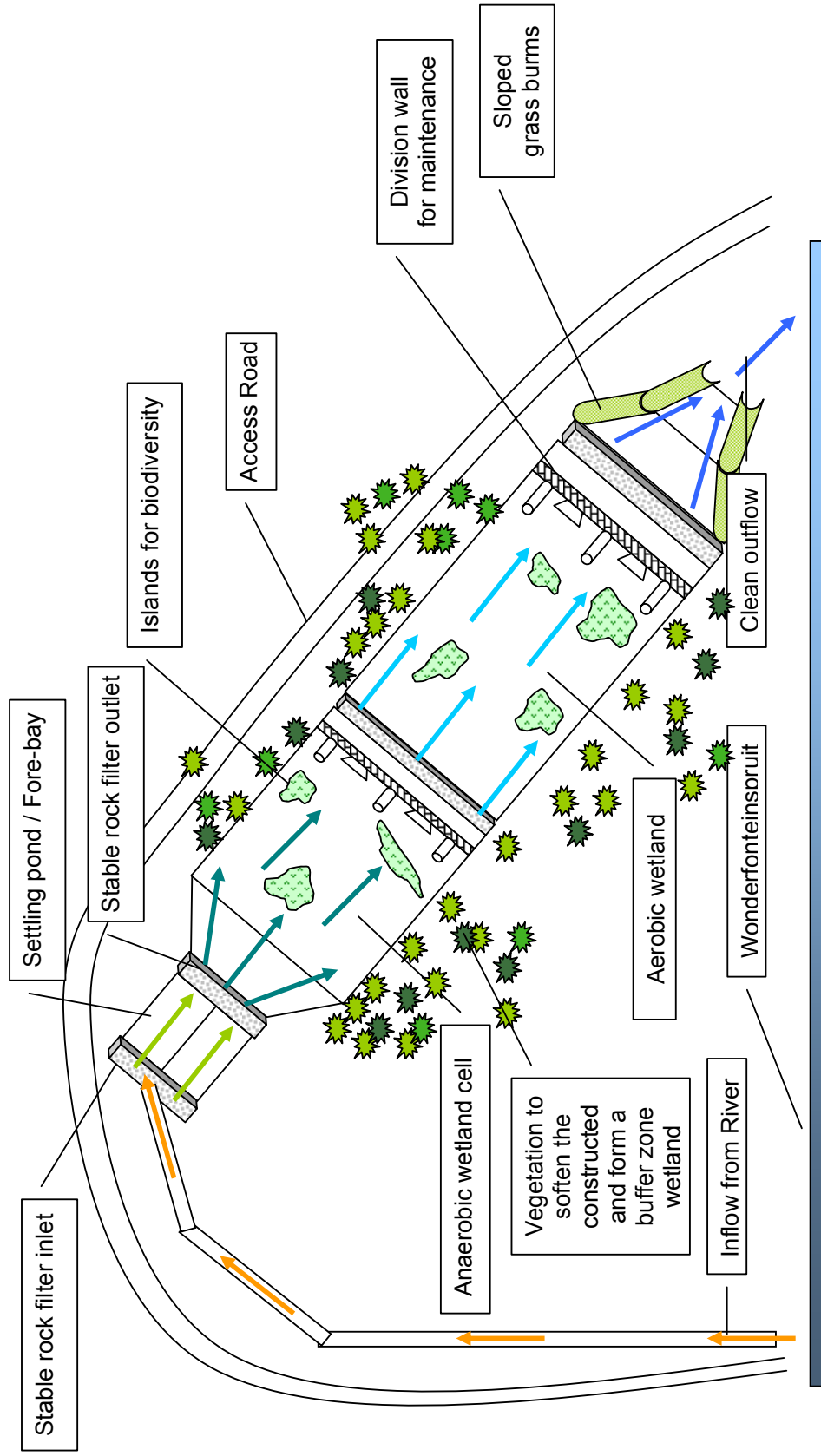

Figure 5.6 WETLAND DESIGN 1

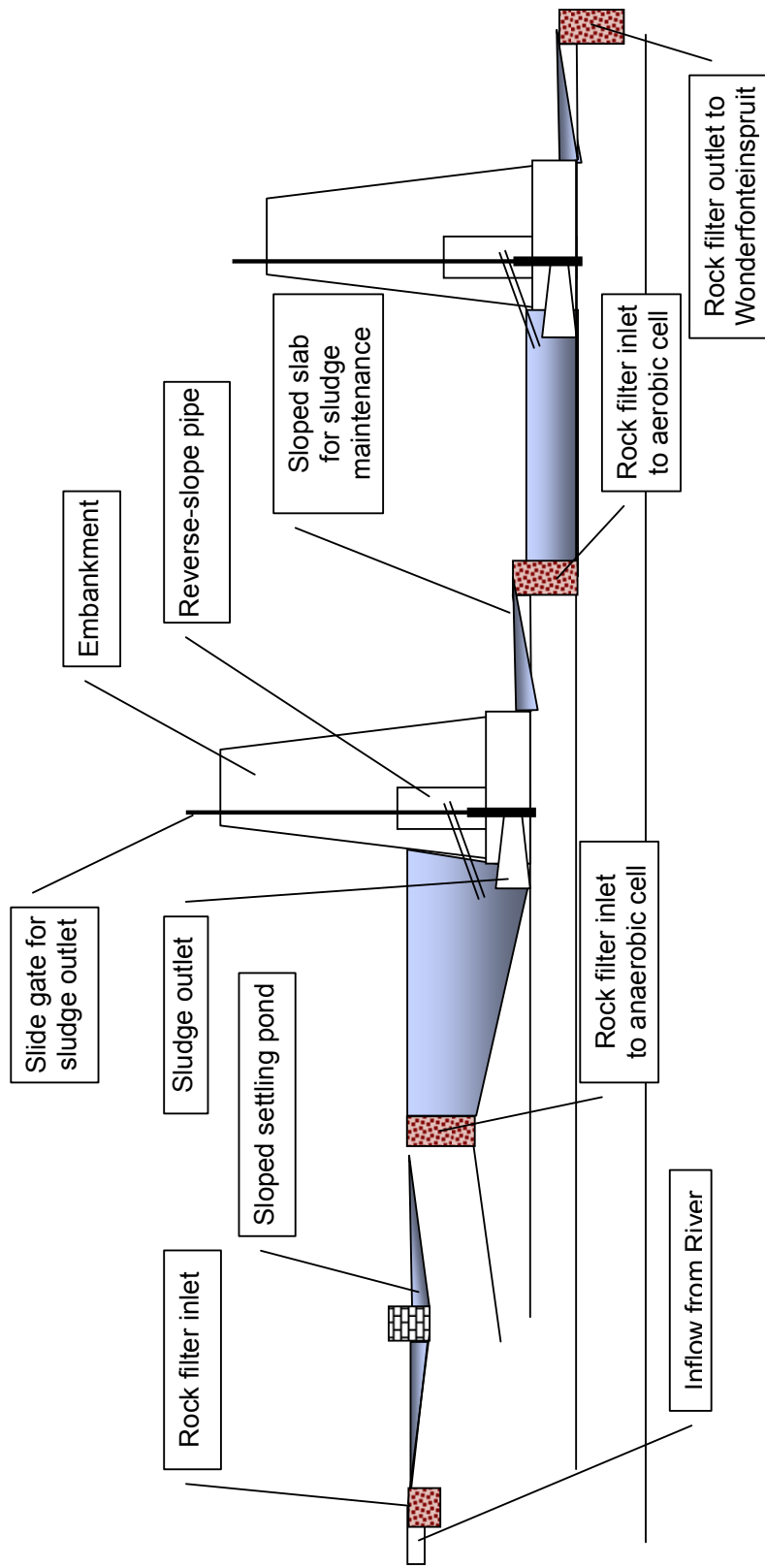

Figure 5.7 WETLAND DESIGN 2 (SIDE VIEW) (Ilze Broekman)

5.4.1 Wonderfontein wetland design

Water will be diverted from the Wonderfonteinspruit into a constructed wetland, gently sloped as per current contours of the area. So the water will gravity feed through the wetland, thus not needing any additional pumping and saving on construction and operational costs. The sloped wetland will also help in the maintenance of the sludge containing most of the heavy metals and pollutants. It is important to remove this sludge on a regular basis to avoid total degradation of the constructed wetland, as was the fatal flaw in so many other constructed wetlands. As can be seen in Figure 5.5 and Figure 5.6, the inlet to the wetland must be a steady distributed inflow to avoid trenches and erosion forming. A rock filter is perfect for this inlet. Aeration prior to the wetland, via rock filters, increases the efficiency of the oxidation process and therefore the precipitation process.

To reduce the maintenance necessary at a later stage, a settling pond or fore-bay has been incorporated into the wetland design where all the coarse particles and sediments will settle before it enters the wetland thereby minimising the sedimentation process in the different cells. The settling pond is sloped from the outer two edges with a wall running in the length in the middle. This will ensure that the sediment will settle next to the side of the wall and the cement bottom can handle a back actor to remove the sludge. The wall also divert the settling pond into two so should maintenance is being done on the one side the other side can still be used by manipulating the in flow to the pond.

After most of the sediments have settled, the water enters the first wetland cell through a rock filter that evenly distributes the water. This cell is the anaerobic cell that will be fed with activated sewage continually to avoid the sulphate reducing bacteria running out of carbon sources. At the outflow of this wetland, a constructed embankment with reverse sloped pipes for the wetland water outflow will prevent clogging from floating debris. At intervals sludge outlets with slide gates are installed and should the sludge level rise, the slide gates are opened and the sludge runs onto the slopes weir cement slab outlet.

The cement slab is sloped in order to trap the contaminated sludge against the weir wall and enable a back actor to remove it with ease. Water from the anaerobic wetland runs through the next rock filter inlet, into an aerobic wetland cell with a lot of islands to attract wildlife and increase a healthy biodiversity. In this cell the last iron can be oxidised and the iron will be trapped in prissily the same type of sludge maintenance system as with the first wetland cell. Thereafter the clean uncontaminated water exit through a rock filter system and is routed to the Wonderfontein system by grasses sloped burms. Two of these systems are required and will treat 70% of contaminated water per diversion. It is planned that after the two wetlands, the water will comply with the SABS standards.

5.4.2 Re-vegetation

The potential of plants to bio accumulate and thereby remove metals from contaminated water has been well identified, either through direct uptake or encrustation. Both *Typha* and *Phragmites* have the ability to accumulate similar levels of iron into their leaves and stems, *Typha* roots usually have a slightly higher iron and manganese concentration than *Phragmites*. Generally contaminants follow the pathways of uptake by nutrients; metals enter the plant organs in ionic form, but may be methylated or chelated. In order to avoid the release of metals when plant decay occurs, a regular cropping and harvesting programme should be implemented.

Plants play a tremendous role in the wetland system. They provide surfaces for bacteria to grow on and act as sediment traps, translocation small quantities of oxygen to the root zone and they produce large amounts of carbon to reduce sulphides in the wetland. These hydrophytic plants have adapted to tolerate the conditions; the zone around their roots or rhizosphere enables the transformation of reduced nutrients into the oxidised form that the plants assimilate. The rhizomes create detoxification conditions that facilitate the conversion of substances that contaminates water.

Pioneer plants like *Typha*, *Cyperus* and *Echinochloa* must be planted along the rock filters, which will provide them with a suitable and protected habitat where local secondary plant communities will establish themselves around the pioneers. The wetland system must be re-vegetated with both *Typha* and *phragmites*. This combination will be more suitable to incorporate the seasonal changes.

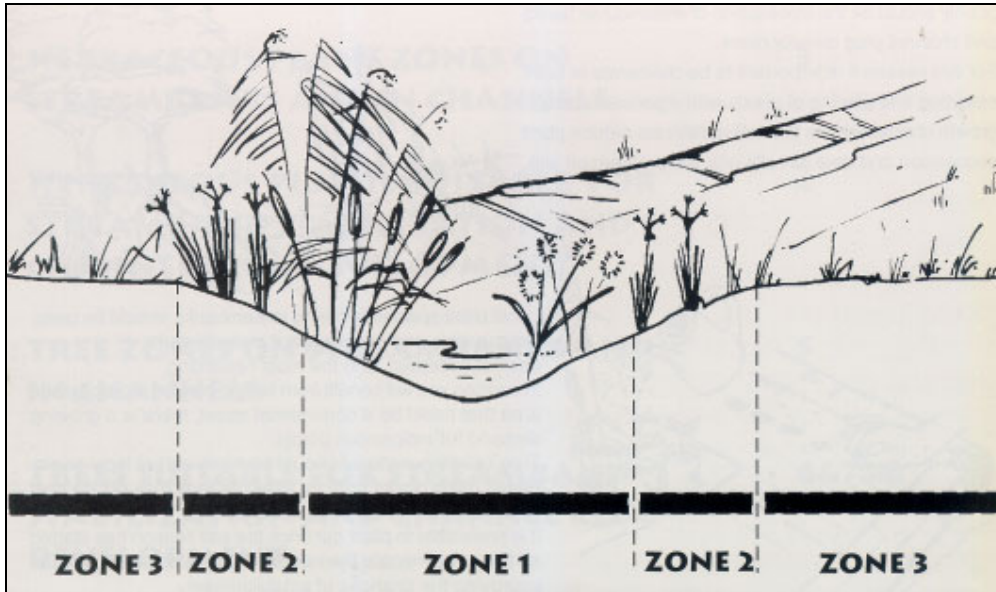

Figure 5.8 ZONES OF A WETLAND (DWAf wetland fix)

- Zone 1 Permanently wet and include Papyrus, reed and bulrush
- Zone 2 Seasonally wet, and frequently waterlogged, this area has sedges, marshes, wet meadow and wet grasslands
- Zone 3 Temporarily wet in short periods during the wet season

A sufficient rooting depth is also required to prevent physical damage to the plants during high velocity storm flows or under freezing conditions. The usual recommendation is for 0.1 m of coarse organic topsoil overlain onto 0.5 m of washed pea gravel. This gives a total depth similar to the 0.6 m depth of root penetration, which may be exceeded in warmer climates. Factors determining the depth of substrate for a sub-surface system include the cost of substrate, depth of root penetration, retention time and climate. Substrate temperatures in excess of 3-5°C must be maintained in order for sulphate reduction processes to precede and cause precipitation of metal and sulphates in the anaerobic zone.

The hydrology of wetlands is generally one of slow flows and either shallow waters or saturated substrates. The slow flows and shallow water depths allow sediments to settle as the water passes through the wetland. The slow flows also provide prolonged contact times between the water and the surfaces within the wetland. The complex mass of organic and inorganic materials and the diverse opportunities for gas/water interchanges foster a diverse community of micro-organisms that break down or transform a wide variety of substances. Most wetlands support a dense growth of vascular plants adapted to saturated conditions.

The plant cover fulfils an important function of intercepting surface run-off and reducing water velocity through the increased resistance caused by the plant stems. This also allows time for water scrubbing, filtering and infiltration into the soil. This vegetation slows the water, creates micro-environments within the water column, and provides attachment sites for the microbial community. The litter that accumulates as plants die back in the fall creates additional material and exchange sites, and provides a source of carbon, nitrogen, and phosphorous to fuel microbial processes.

The shape of the cells shall be such that there are no narrow, L-shaped or elongated portions. Round or rectangular ponds are most desirable. Rectangular ponds should generally have a length not exceeding three times the width. Dikes should be rounded at the corners to minimise accumulation of floating material.

5.4.3 Plant list selected for Wonderfontein wetland

The selection was made on plants that already exist in the Wonderfontein area and other areas of the mine property in the vicinity (see Appendix A for the plant list and detailed drawings of the vegetation). Re-vegetation with local plant species is beneficial because:

- The plant species required are not commercially available;
- These plants are acclimatised to the region;
- They are adjusted to the low ph and high sulphate/iron load;

- Harvesting to replanting time can be cut to the minimum, lowering stress on the plant and ensuring better root establishment;
- It's cost efficient to divide the mother plant for re-vegetation material.

The best way to harvest these plant samples is to dig out clumps with a spade and trim the foliage down to approximately 100 mm to reduce transpiration. Transporting these plants to the wetland as soon as possible and keeping them out of direct sunlight is essential. Plant them as whole clumps, three plants per square meter. This must be done in the active growing season, preferably just after a rainstorm. A sufficient rooting depth of 0.6 m is also required to prevent physical damage to the plants during high velocity storm flows or under freezing conditions.

5.5 Positioning of wetland

In order to treat the Wonderfonteinspruit contaminated water with a wetland system and still preserve the ecological integrity of the stream, a percentage of the water will be diverted from the main stream into a wetland adjacent to the stream. As illustrated in Figure 5.9 and Figure 5.10, there are two major impact areas where the most severe contamination occurs, firstly at the attenuation dam where the acid mine drainage enters the Wonderfonteinspruit and the second at sampling point 8-10 where the Cooke 1 plant discharges its effluent into the study area.

A two wetland system is planned for the treatment of the Wonderfonteinspruit water where 70% of the stream will be diverted into the first wetland just after the outflow of the attenuation dam where the acid mine drainage enters the study area. The contaminated water will flow through the wetland at an appropriate rate to ensure adequate retention time for treatment of the different chemical elements that are problematic in the water. The second wetland will be constructed downstream of sampling point number 8 where the Cooke 1 plant discharges its effluent into the river and seems to be the second largest impact on the river. Again 70% of the Wonderfonteinspruit will be diverted into the

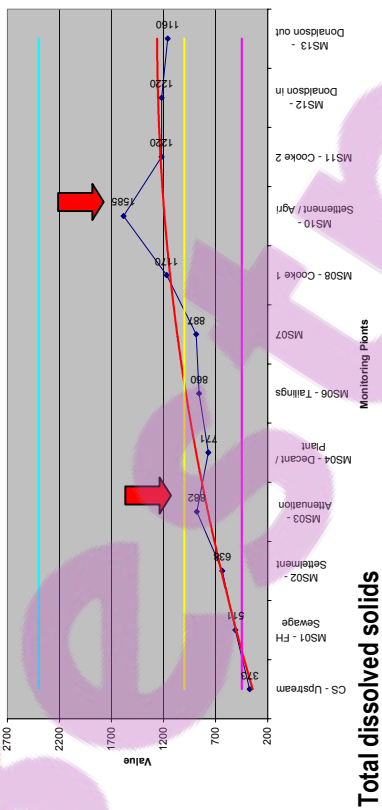
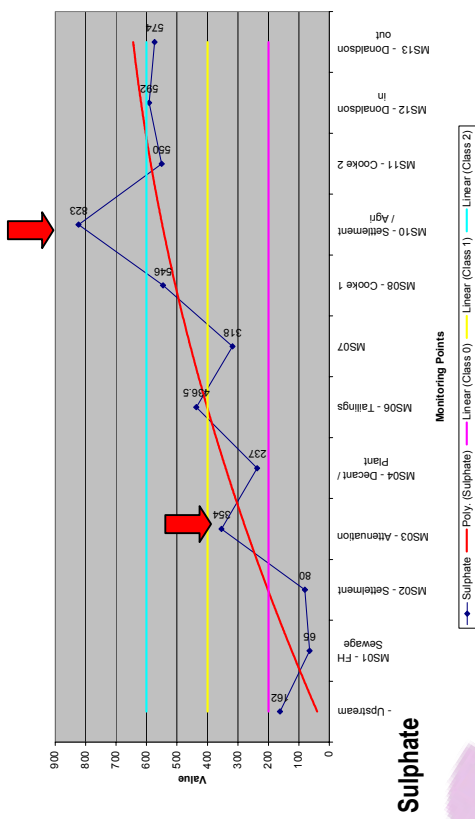

Figure 5.9 CHEMICAL ANALYSIS FOR TDS AND SULPHATE FOR WONDERFONTEINSRUIT

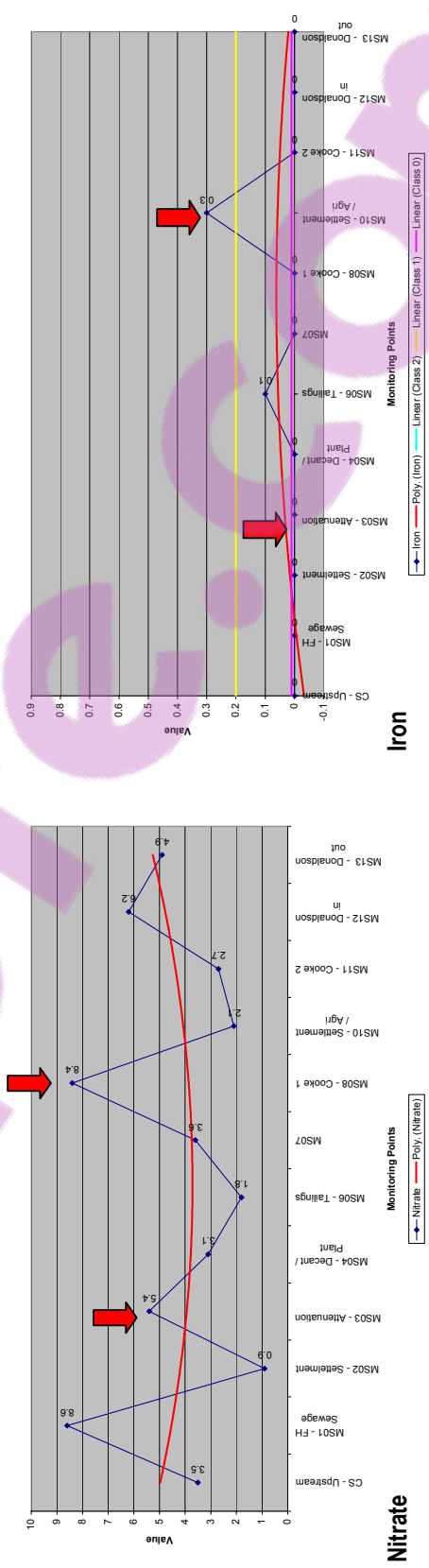

Figure 5.10 CHEMICAL ANALYSIS FOR AND NITRATE AND IRON FOR WONDERFONTEINSRUIT

second wetland, thus ensuring a double cleanup of 140% and diluting any contaminants that might not have made it through one of the wetlands.

5.6 Delineation

5.6.1 Lining

Wetland pond lining is required in permeable soils to prevent vertical movement of contaminated water. Synthetic or clay liners add significant cost to a wetland project especially when clay is not readily available. Historically the Wonderfonteinspruit area must have been a wetland area, an analysis on the ground were done and a lot of mottling were observed in the area, this is an indication that the area were waterlogged and are suitable for a wetland. This would bring the cost for constructing a wetland down a considerably amount, because no lining is necessary and there already exist numerous wetland plant species in this study area.

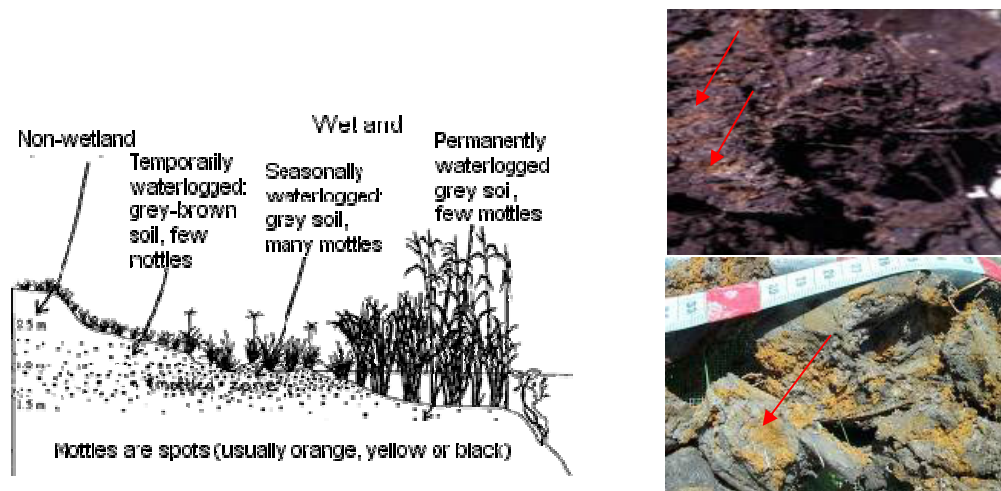

Figure 5.11 MOTTLING OF WATER DRENCHED SOILS

5.6.2 Delineation methods

To best design a wetland for the treatment of the contaminated water, it is important to delineate the historical wetland where the Wonderfonteinspruit is now flowing. In doing so the best results will be obtained and establishment will

be successful (DWAF, 2003). Wetlands must have one or more of the following attributes:

- Wetland (hydromorphic) soils that display characteristics resulting from prolonged saturation;
- The presence, at least occasionally, of water loving plants (hydrophytes);
- A high water table that results in saturation at or near the surface, leading to anaerobic conditions developing in the top 50 cm of the soil. If the geohydrological impact is considered, it is shown that the water table is very low and in some instances replenishes the Wonderfonteinpruit.

It would be required not to expand the planned wetland onto soil that is not suitable for saturation conditions. At best it should stay within the natural outer edge of the 'Wonderfontein wetland area'. Therefore delineation is crucial before the designing can start. Three factors are important in the delineation of a wetland:

- The Soil Form Indicator identifies the soil forms, which are associated with prolonged and frequent saturation;
- The Soil Wetness Indicator identifies the morphological "signatures" developed in the soil profile as a result of prolonged and frequent saturation;
- The Vegetation Indicator identifies hydrophilic vegetation associated with frequently saturated soils. •

5.6.2.1 Soil Form Indicator

The Soil Form Indicator identifies the soil forms, as defined by the Soil Classification Working Group (1991), which are associated with prolonged and frequent saturation. A hydromorphic soil displays unique characteristics resulting from its prolonged and repeated saturation. Once a soil becomes saturated for an extended time, roots and micro-organisms gradually consume the oxygen present in pore spaces in the soil. In an unsaturated soil, oxygen consumed in this way would be replenished by diffusion from the air at the soil surface. However, since oxygen diffuses 10 000 times more slowly through water than through air, the process of replenishing depleted soil oxygen in a

saturated soil is significantly slower. Thus, once the oxygen in a saturated soil has been depleted, the soil effectively remains anaerobic.

These anaerobic conditions make wetlands highly efficient in removing many pollutants from water, since the chemical mechanisms by which this is done need to take place in the absence of oxygen. Iron is one of the most abundant elements in soils, and is responsible for the red and brown colours of many soils. Once most of the iron has been dissolved out of a soil as a result of prolonged anaerobic conditions, the soil matrix is left a greyish, greenish or bluish colour, and is said to be gleyed (DWAF, 2003).

A fluctuating water table common in wetlands that are seasonally or temporarily saturated, results in alternation between aerobic and anaerobic conditions in the soil. Lowering of the water table results in a switch from anaerobic to aerobic soil conditions, causing dissolved iron to return to an insoluble state and be deposited in the form of patches or mottles in the soil. Recurrence of this cycle of wetting and drying over many decades concentrates these bright, insoluble iron compounds. Thus, soil that is gleyed but has many mottles may be interpreted as indicating a zone that is seasonally or temporarily saturated.

5.6.2.2 Soil Wetness Indicator

The Soil Wetness Indicator identifies the morphological "signatures" developed in the soil profile as a result of prolonged and frequent saturation. The hydromorphic soils must display signs of wetness within 50 cm of the soil surface. This depth has been chosen because experience internationally has shown that frequent saturation of the soil within 50 cm of the surface is necessary to support hydrophytic vegetation (DWAF, 2003).

The identification of signs of wetness within 50 cm of the soil surface is usually a relatively simple procedure except for a few specific cases:

Temporary zone

- The boundary of the wetland is defined as the outer edge of the temporary zone of wetness;

- Minimal grey matrix (<10%);
- Few high chroma mottles / brightly coloured mottles;
- Short periods of saturation (less than three months per annum).

Seasonal zone

- Significant periods of wetness (at least three months per annum);
- Grey matrix (>10%);
- Many low chroma mottles present / less brighter coloured mottles.

Permanent zone

- Prominent grey matrix;
- Few to no high chroma mottles; / few to no bright coloured mottles;
- Wetness all year round;
- Sulphuric odour (rotten egg smell).

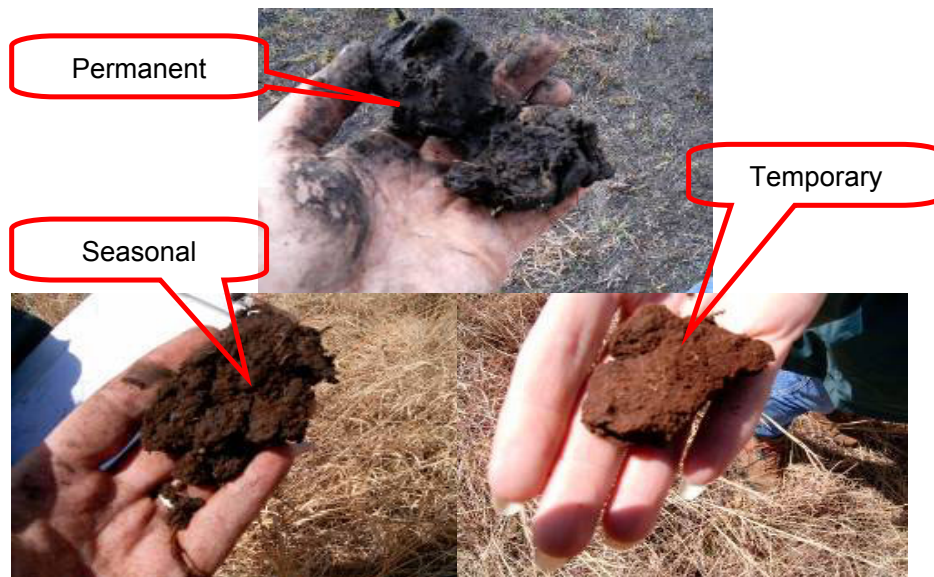

Figure 5.12 SOIL VARIATION FOR DIFFERENT SECTIONS IN THE WETLAND

5.6.2.3 Vegetation Indicator

The Vegetation Indicator identifies hydrophilic vegetation associated with frequently saturated soils. Starting the delineation procedure from the downstream part of the area to be delineated, look for the wettest part of the wetland using cues such as the presence of water or obligate hydrophilic vegetation such as sedges, bulrushes or reeds. Use a soil auger to examine the

first 50 cm of the soil profile for the presence of soil wetness and/or soil form indicators. Determine the wetness zone according to the soil and vegetation indicators. Proceed outward towards the estimated edge of the wetland, sampling at regular intervals to check soil wetness and vegetation indicators. The outer boundary of the wetland is defined as the point where the indicators are no longer visible (DWAF, 2003).

Land where the water table is usually near the surface or the land and is periodically covered with shallow water, supports vegetation typically adapted to life in saturated soil. Wetlands must have one or more of the following attributes: 1) Wetland (hydromorphic) soils that display characteristics resulting from prolonged saturation; 2) The presence, at least occasionally, of water loving plants (hydrophytes); 3) A high water table that results in saturation at or near the surface, leading to anaerobic conditions developing in the top 50 cm of the soil.

It is not a very useful parameter for accurately identifying the outer boundary of a wetland. Long term monitoring is needed to accurately characterise the hydrology of a wetland and the extent of its saturation zones. As a result of this dynamic hydrology within and between wetlands, it is difficult to define the minimum frequency and duration of saturation that creates a wetland. Instead, an approach is commonly followed which identifies the indirect indicators of prolonged saturation by water namely, wetland plants (hydrophytes) and wetland (hydromorphic) soils.

The presence of these distinctive indicators in an area implies that the frequency and duration of saturation is sufficient to classify the area as a wetland. In many wetlands, not all parts are saturated for the same length of time. Generally, there are three different zones in a wetland, which are distinguished according to the changing frequency of saturation. These three zones may not be present in all wetlands (DWAF, 2003).

The central part of the wetland, which is nearly always saturated, is referred to as the *permanent zone* of wetness. This is surrounded by the *seasonal zone*,

which is saturated for a significant duration of the rainy season. The *temporary zone* in turn surrounds the seasonal zone, and is saturated for only a short period of the year that is sufficient, under normal circumstances, for the formation of hydromorphic soils and the growth of wetland vegetation. The object of the delineation procedure is to identify the outer edge of the temporary zone. This outer edge marks the boundary between the wetland and adjacent terrestrial areas.

5.6.2.4 Wetland indicators

Table 5.4 CRITERIA FOR DISTINGUISHING DIFFERENT SOIL SATURATION (DWAF, 2003)

Soil	DEGREE OF WETNESS		
	Temporary	Seasonal	Perm./Semi-perm.
Soil depth 0-10 cm	Matrix brown to greyish brown (chroma 0-3, usually 1 or 2) Few/no mottles Nonsulphidic	Matrix brownish grey to grey (chroma 0-2) Many mottles Sometimes sulphidic	Matrix grey (chroma 0-1) Few/no mottles Often sulphidic
Soil depth 30-40 cm	Matrix greyish brown (chroma 0-2, usually 1) Few/many mottles	Matrix brownish grey to grey (chroma 0-1) Many mottles	Matrix grey (chroma 0-1) No/few mottles Matrix chroma: 0-1
Vegetation If herbaceous	Predominantly grass species; mixture of species which occur extensively in non-wetland areas, and hydrophytic plant species which are restricted largely to wetland areas	Hydrophytic sedge and grass species which are restricted to wetland areas, usually <1m tall.	Dominated by: (1) emergent plants, including reeds (<i>Phragmites australis</i>), sedges and bulrushes (<i>Typha capensis</i>), usually >1 m tall (marsh); or (2) floating or submerged aquatic plants.
If woody	Mixture of woody species which occur extensively in non-wetland areas, and hydrophytic plant species which are restricted largely to wetland areas	Hydrophytic woody species which are restricted to wetland areas	Hydrophytic woody species, which are restricted to wetland areas. Morphological adaptations to prolonged wetness (e.g. prop roots).

Finding the outer edge of the temporary zone requires the delineator to give consideration to four specific indicators. The Terrain Unit Indicator helps to identify those parts of the landscape where wetlands are more likely to occur. Within an area that has been identified as a wetland, use the descriptions given in Table 5.4 to determine which of the different zones are represented. Delineations were done on the two chosen sites for the proposed wetlands, as

can be seen in Figure 5.13 the wetland soil continues for the amount of meters the red line indicates.

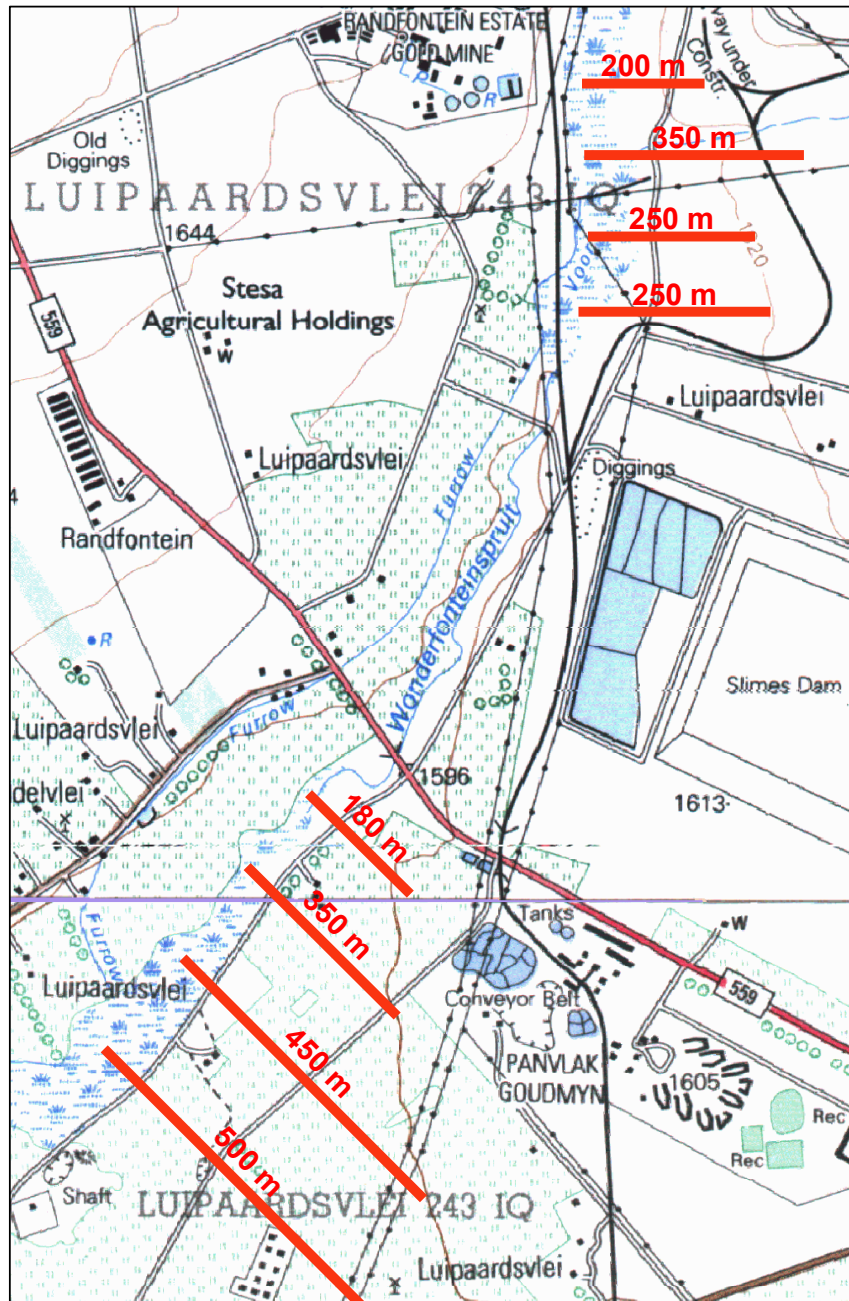

Figure 5.13 DELINEATION LINES OF PROPOSED WETLAND AREA.

5.7 Other mitigation methods

5.7.1 Tailings dam leaching (Conductivity and TDS)

The electrical conductivity of water is directly connected to the concentration of dissolved solids in the water. Ions from the dissolved solids in water influence the ability of that water to conduct an electrical current, which can be measured using a conductivity meter. When correlated with laboratory TDS measurements, electrical conductivity can provide an accurate estimate of the TDS concentration. Total dissolved solids (TDS) are a measure of the total amount of all the materials that are dissolved in water. These materials, both natural and anthropogenic (made by humans) are mainly inorganic solids, with a minor amount of organic material.

An elevated total dissolved solids (TDS) concentration is not a health hazard. The TDS concentration is a secondary drinking water standard and therefore is regulated because it is more of an aesthetic rather than a health hazard. An elevated TDS indicates that the concentration of the dissolved ions may cause the water to be corrosive, salty or brackish taste resulting in scale formation, and interference and decrease efficiency of hot water heaters.

With respect to trace metals, elevated TDS may suggest that toxic metals may be present at an elevated level. It is important to keep in mind that water with a very lower TDS concentration may be corrosive and corrosive waters may leak toxic metals such as copper and lead from the piping. The TDS values almost doubled in the vicinity of sample number 7 and 8 taken in the Wonderfonteinspruit. These concentrations indicate leaching through the tailings dam into the stream increasing the TDS and conductivity levels and have an impact on the sulphate levels as well. It is planned in the near future to reprocess the tailings for gold ore, thus making it not worthwhile spending too much time and capital on this problem.

Liners have not been incorporated into tailings impoundment designs until the last decade or two, and the cost of lining the tailings dam for such a short period

of a year or two is not a viable option. The best option will be to minimise the contamination into the stream. Doing this, the surface water quality will dramatically improve to provide much needed water for this area. Some remediation methods to contain the tailings dam contamination are the following:

- Cut-off trenches are the most widely used type of embankment barrier for tailings dams.
- Dewatering may be necessary during the installation of cut-off trenches when they are installed below the ground water table.
- Slurry walls are narrow trenches that are best suited to sites with a level topography. The slurry walls are installed by excavating a trench to a zone of low permeability material and filling the trench with soil/bentonite slurry, which is then allowed to set to a consistency of clay. Depths average 40 feet and permeabilities obtained can be as low as 10^{-7} cm/sec.
- Grout curtains use cement, silicate materials, or acrylic resins as a barrier to seepage movement and can extend to depths of more than 100 feet. Permeabilities obtained can be as low as 10^{-8} cm/sec (Vick, 1990).
- Pump back systems consist of seepage ponds and/or seepage collection wells installed down gradient of the impoundment that are outfitted with pumps that send seepage back to the impoundment or for use as process water.
- Current practices include the use of toe ponds or seepage ponds to collect seepage. In some cases, under drains or toe drains are designed to flow into the seepage pond. In other cases, however, these systems are installed after construction of the impoundment as a remedial action to collect unanticipated seepage.
- The suggestion is to use the pump-back system in conjunction with slurry walls, cut-off trenches or grout curtains to minimise down gradient seepage.
- Controlling the pollution or more directly the total dissolved solids from the tailings dam, an estimated of the increased 65% increase in values due to the contamination can be subtracted from our values. The aim is to reduce the TDS to a class 0 value below 450 mg/l and conductivity to <70 mS/m.

5.8 Conclusion

Calculations have been done on the size of wetlands that would be able to treat the contaminants. Sewage will be added at a calculated rate to avoid carbon depletion and the die back of sulphate reducing bacteria. Lastly a pump-back system must be built where the tailings dam leaches.

Chapter 6

CONCLUSION

6.1 Introduction

Due to decanting of dormant mine shafts in the vicinity of the Wonderfonteinspruit, the water quality and volume are impacted on immensely. South Africa is an arid country with only 8.6% of the rainfall being available as surface water. South Africa cannot afford to do nothing while freshwater bodies are being polluted hence the motivation for the study and the relevance to urgent issues in the environmental management sector.

6.2 Summary of the study

One of the main culprits of water pollution is the mining industry. When mining activities were discontinued in 2000, the defunct workings started to flood and in September 2002 the mine water started to decant from the West Rand Mine Basin (WRB) next to the Tweelopie East Stream. The Department of Water Affairs and Forestry (DWAF) intervened and forced the mine to pre-treat the decant water, which resulted in the mine decant water being treated through a process of lime addition and aeration, as well as secondary treatment through a wetland system. The treated water is currently used in the mine's metallurgical plants and 15 MI per day of treated water is disposed firstly into the Cooke Attenuation Dam and then discharged into the Wonderfonteinspruit.

AMD occurs as a result of the oxidation of sulphide minerals when they are exposed to free oxygen and water during the mining process. As long as pyrite remains buried deep underground within the rocks of the Witwatersrand and Transvaal Super groups, the sulphur remains in a stable, reduced state. However, when it is exposed to free oxygen in the presence of water, a series of chemical reactions occur, which ultimately gives rise to the production of acidic water that is high in iron and sulphate as is the case in the Wonderfonteinspruit.

The aim of this study was to provide remediation measures as a result of AMD and other impacting factors on the water quality and volume in the Wonderfonteinspruit. To better understand the problem and recommend the best solution, the researcher undertook a detailed desktop study, an examination of aerial photographs/topocadastral maps, interviews, sampling of both chemical and microbial flow volumes, and the calculation of evapo-transpiration ratios. From this data, five main contributors were identified as the contaminators of the Wonderfonteinspruit, namely the AMD from the decant point, townships, Flip Human sewage works, the tailings dam and some agricultural activities along the river.

Bearing the literature review in mind that identified all the expected impacts, it was concluded that the following impacts were the main contributors to the water quality and volume of the Wonderfonteinspruit. Firstly, the impact of water quality was investigated with pH not being such a big problem, as the pre-treatment plant neutralises the pH. Conductivity and total dissolved solids (TDS) were highest at the point where the tailings dam leached into the Wonderfonteinspruit. Sulphate was very high, as was expected from AMD.

The best way to treat the high sulphate is with sulphate-reducing bacteria. To avoid the fatal flaw of many other constructed wetlands, a continuous carbon source is provided to the bacteria in the form of activated sewage from the Flip Human sewage treatment plant. Iron and other heavy metals are precipitated through oxidation reactions to form oxides and hydroxides from the aerobic cell in the wetland. The wetlands are also known for their ability to reduce nitrate and microbial values with great success. With water retention and evapo-transpiration, the 15 Ml of additional water will also be managed.

In the remediation four elements that do not comply with the SABS criteria for class 0 water were chosen for improvement. Conductivity falls within class 1 and has a maximum of 178 mS/m @25°C, which should be reduced to under 70 mS/m. Total dissolved solids have a value of 1585 mg/l, which is much higher than the prescribed 450 ml/l, making it class 2 water. The last two problematic elements are both considered as class 2 water, namely sulphate peaks at 592

mg/l whereas the preferred value is 200 mg/l, and iron should be 0.01 mg/l, not the staggering 0.3mg/l.

Alternative mitigation methods were identified and analysed for the impacts of the big five contaminants, and everything comes down to constructed wetlands. This is not a straightforward solution, however, and a specific design to accommodate all the different pollutants and water quality ranges was created. The basic design was the correct in- and outflow weirs, with a settling pond to ease the sedimentation management, followed by an anaerobic cell. A specific sedimentation weir with gravity pipes was designed to minimise clogging, and then an aerobic cell that finally leads to Wonderfonteinspruit.

A combination of two factors was a crucial requirement to completely remove iron and sulphate, namely aerated and un-aerated conditions. Iron precipitates in contact with aerated water whereas sulphate will effectively be removed with the help of sulphate-reducing bacteria that, in turn, need un-aerated water conditions.

Other site-specific factors were incorporated into the wetland design and calculations were done on iron-removal capacity that indicated two wetlands of 412 m² and 1100 m² aerobic wetland and an estimated size for anaerobic with 1.7 Ml/d per wetland of sewage to recharge the sulphate-reducing bacteria's carbon source. Certain plants that would adapt to the area were identified and chosen for their ability to reduce and take up heavy metals from AMD water.

To avoid using a lining as the base of the wetland, delineation was done to identify the best position for the wetland, thus using the appropriate wetland soil type that occurs naturally in the area. An analysis on the ground was done and a lot of mottling was observed in the area. This was an indication that the area was waterlogged and suitable for a wetland. This would bring the cost for constructing a wetland down considerably, because no lining is necessary and numerous wetland plant species already occur in this study area.

Two wetlands were identified in concurrence that each treat 70% of the diverted water of Wonderfonteinspruit. The locality of these two wetlands was of great importance. There are two major impact areas where the most severe contamination occurs, namely at the attenuation dam where the AMD enters the Wonderfonteinspruit, and at sampling point 8-10 where the Cooke 1 plant discharges its effluent into the study area. The two wetlands were placed in those crucial areas to optimise the treatment capabilities.

The other mitigation methods included a cut-off trench and pump-back system for the tailings dam in corporation with a monitoring programme. The sewage works should be optimised and better managed. Both the settlement and agricultural sector need to be educated on their respective impacts on the environment, and government assistance should be available.

6.3 Concluding comments

Various remediation measures are therefore recommended to remediate and mitigate the impacts of the five major contaminants of the Wonderfonteinspruit. Once these measures, together with a comprehensive monitoring plan are implemented, the impacts on water quality and volume should be mitigated and the general state of the Wonderfonteinspruit improved.

The findings and recommendations of this study should contribute significantly to minimising AMD and improving and sustaining the water quality and supply to the surrounding environment. Furthermore, educating the mining sector, farmers and the community on the causes and effects of AMD should promote responsible management for and ownership of the environment.

References

Allanson B.R., Hart R.C., O'Keeffe J.H. & Robarts R.D. (1990). Inland waters of Southern Africa: An ecological perspective. Dordrecht (Netherlands): Kluwer.

Andreoli C.V. (1993). The influence of agriculture on water quality. In: Prevention of water pollution by agriculture and related activities. Proceedings of the FAO Expert Consultation, Santiago, Chile, 20-23 October 1992. Water Report 1. Rome: FAO, pp. 53-65.

ANZECC (1992). National water quality guidelines. Perth. Australia and New Zealand Environment and Conservation Council.

Atlas R.M. & Barthas R. (1998). Microbial ecology: Fundamentals and applications (3rd ed.). California, United States Benjamin-Cummings Publishing.

American Water Works Association (AWWA), Edward E. Baruth (1971). Water treatment plant design. Water Environment Federation. American Water Works Association. American Society of Civil Engineers. Mac-graw hill professionals New York.

Ball L. (1993). A status and research review of the Con operations tailings system. Report submitted to the Northwest Territories Water Board. Northern Inland Waters Act, Water License NIL3-0040, Cominco Ltd., Con Operations, Northwest Territories, Canada.

Boyle R.W. (1965). Geology, geochemistry, and origin of the lead-zinc-silver deposits of the Keno Hill-Galena Hill area, Yukon Territory. Geological Survey of Canada Bulletin, 111

Brant D.L., & Ziemkiewicz P.F. (1997). Passive removal of manganese from acid mine drainage. P. 741-744, in: Proceedings of the 1997 Annual Meeting of the American Society for Surface Mining and Reclamation.

Bredenkamp D.B., Van der Westhuizen C., Wiegmans F.E. & Kuhn, C.M. (1986). Groundwater Supply Potential of Dolomite Compartments West of Krugersdorp. Technical Report No. GH3440. Pretoria: Directorate of Geohydrology, Department of Water Affairs.

Brink A.B.A. (1979). Engineering geology of Southern Africa, Vol. 1: The first 2000 million years of geological time. Pretoria: Building Publications.

Brodie G.A. (1991). Achieving compliance with staged, aerobic constructed wetlands. In: Proceedings, 1991 of the annual meeting of the American Society of Surface Mining Reclamationists, Durango, CO.

Brooks R., Samuel D.E. & Hill J.B. (1985). Wetlands and water management on mined lands. Proceedings of a Conference. The Pennsylvania State University, University Park, PA

Buisman C.J.N., Lettinga G., Paasschens C.W.M. & Habets L.H.A. (1991). Biotechnological sulphide removal from effluents. Water Science and Technology vol. 24, no. 3-4, p. 347-356.

CCREM (Canadian Council of Resource and Environment Ministers) (1987). Canadian water quality guidelines. Ottawa (Canada): Task Force on Water Quality Guidelines.

CCREM (Canadian Council of Resource and Environment Ministers) (n.d.). Canadian water quality guidelines. Ottawa (Canada): Ecosystem Conservation Directorate, Environment Canada (periodically updated).

CWP (1995) Pollutant dynamics within storm water wetlands: 1. Plant uptake. Techniques, Vol. 1, No.4. Silver Springs, MD.

Dallas H.F., Day J.A. & Reynolds E.G. (1995). The effects of water quality variables on riverine biotas. Final Report 351/1/94. Pretoria, South African Water Research Commission.

Davé N.K. (1993). Panel wetlands: A case history of partially submerged pyretic Uranium tailings under water. MEND Project 3.12.2. Ottawa (Canada): Canada Centre for Mineral and Energy Technology (CANMET).

Day J.A. (1993). The effect of water quality variables on riverine ecosystems: A review. Technical Report TT61/93. Pretoria, South African Water Research Commission.

Day J.A. & King J.M. (1995). Geographical patterns, and their origins, in the dominance of major ions in South African rivers. South African Journal of Science, 91, 299-306.

De Kock W.P. (1964). The geology and economic significance of the West Wits Line: The geology of some ore deposits in Southern Africa. Juta: Cape Town.

Dollhopf (1988). Hydrochemical, vegetational and microbiological effects of a natural and a constructed wetland on the control of acid mine drainage. In: Report No. RRU 8804, Montana Dept. of State Lands, Abandoned Mine Reclamation Bureau, Helena.

Dias F.F. Bhat JV. (1965) Microbial Ecology of Activated Sludge: II. Bacteriophages, Bdellovibrio, Coliforms, and Other Organisms. Applied Microbiology, 13 (2), 257–261.

DME (2000). Water Quality Protection Guidelines No. 2: Mining and Mineral Processing - Tailings facilities. Johannesburg, Water and Rivers Commission & Department of Minerals and Energy, Western Australia, p. 11.

Du Plessis C. & Landman K. (2002). Sustainability analysis of human settlements in South Africa. Report prepared for the national Department of Housing. Pretoria: CSIR.

Duex T.A. (1994). Acid rock drainage at the Richmond Hill Mine, Lawrence County, South Dakota. In: Proceedings of the Fifth Western Regional Conference on Precious Metals, Coal and the Environment, October. Lead, SD: Society for Mining Metallurgy and Exploration Inc. pp. 124-134.

Durkin T.V. (1994). Acid mine drainage: An old problem with new solutions - Reclamation at the Richmond Hill Mine, South Dakota. In: Proceedings of the Fifth Western Regional Conference on Precious Metals, Coal and the Environment, October. Lead, SD: Society for Mining Metallurgy and Exploration Inc. pp. 16-24.

DWAF (Department of Water Affairs and Forestry) (1986). Management of the water resources of the Republic of South Africa. Johannesburg, Republic of South Africa

DWAF (1999a). Quality of domestic water supplies, volume 1: Assessment guide. Pretoria: Department of Water Affairs and Forestry.

DWAF (1999b). Managing the water quality effects of dense settlements. National strategy and policy document. Pretoria: Department of Water Affairs and Forestry.

DWAF (Department of Water Affairs and Forestry (2002).
http://www.dwaf.gov.za/Documents/Other/WMA/008_Upper%20Vaal.ppt access date:
30-11-2007

DWAF (2002). National water resource quality status report: Inorganic chemical water quality of surface water. Pretoria: Department of Water Affairs and Forestry.

DWAF (2003). A practical field procedure for identification and delineation of wetlands and riparian areas. Pretoria: Department of Water Affairs and Forestry.

Edmunds W.M. (1987) Baseline geochemical conditions in the Chalk aquifer, Berkshire, U.K: a basis for groundwater quality management. Geochemistry ISSN 0883-2927, vol. 2, n^o3. Elsevier, Oxford, ROYAUME-UNI

Eger P. & Lapakko K. (1988). Nickel and copper removal from mine drainage by a natural wetland. U.S. Bureau of Mines Circular 9183, 301-309. Neoproterozoic-Paleoproterozoic, South Africa

Eriksson K.A. & Truswell J.F. (1974). Stratotypes from the Malmani subgroup northwest of Johannesburg, South Africa. Transactions of the Geological Society of South Africa.

FAO/ECE. (1991). Legislation and measures for the solving of environmental problems resulting from agricultural practices (with particular reference to soil, air and water), their economic consequences and impact on agrarian structures and farm rationalization. United Nations Economic Commission for Europe (UNECE) and FAO, Agri/Agrarian Structures and Farm Rationalization Report No. 7. Geneva: United Nations.

FARM & HOME ENV MNG (2008) Newsletter of Winter & Spring 2003. Madison, Hiram Smith Hall <http://www.uwex.edu/AgEMS/newsletter/winterspring03.html> access date: 25-11-2007

Faulkner B.B. & Skousen J.G. (1994). Treatment of acid mine drainage by passive treatment systems. In: Volume 2 of Proceedings of the International Land Reclamation and Mine Drainage Conference and the Third International Conference on the Abatement of Acidic Drainage, 24–29 April. Pittsburgh, PA:

Ferguson, K.A., Hutchison, I.P.G. & Schiffman, (1985). Water Balance Approach to Prediction of Seepage Through Mine Impoundments, Part II, Theoretical Aspects of Water Balance, Approach to Seepage Modeling and Detailed Case Histories, Seepage and Leakage from Dams and Impoundments, Eds. ASCE, NY

Forstner U. (1981). Metal concentrations in river, lake and ocean waters. In: U. Forstner & G.T.W. Wittmann (Eds), Metal pollution in the aquatic environment (2nd ed.), pp. 71-109. Berlin (Germany): Springer-Verslag.

Fortin D., Goulet R. & Roy M. (2000). Seasonal cycling of Fe and S in a constructed wetland: The role of sulphate-reducing bacteria. Geomicrobiology Journal, 17, 221-235.

Greenberg A.E., Clesceri L.S. & Eaton A.D. (1995). Standard methods for the examination of water and wastewater (19th ed.). Washington, D.C.: American Public Health Association (APHA), American Water Works Association, and Water Pollution Control Federation.

Gilliam J.W., Skaggs R.W. & Weed S.B. (1978). An evaluation of the potential for using drainage control to reduce nitrate loss from agricultural fields to surface waters. Report no. 128. Raleigh, NC: Water Resources Research Institute, University of North Carolina.

Golterman H.L., Clymo R.S. & Ohnstad M.A.M. (1978). Methods for physical and chemical analysis of fresh waters. In: IBP handbook no. 8 (2nd ed.). Oxford (U.K.): Blackwell Scientific Publications.

Gormely L., Higgs T.W., Kistriz R.U. & Sobolewski A. (1990). Assessment of wetlands for gold mill effluent treatment. Report prepared for the Mine Pollution Control Branch of Saskatchewan Environment and Public Safety. Saskatoon, SK (Canada): Saskatchewan Environment and Public Safety. 63 pp.

Govind R., Yong W. & Tabak H. (1999). Studies on biorecovery of metals from acid mine drainage. In: A. Leeson & B. Allemans (Eds), Bioremediation of metals and inorganic compounds, p. 37. Proceedings of 5th International In Situ and On-Site Bioremediation Symposium, San Diego, CA, April 19-22. Columbus, OH: Battelle Press.

Hambley A.G. (1996). Removal of nickel from mine water by a natural wetland in Northern Manitoba. M.N.R.M. thesis. Winnipeg (Canada): University of Manitoba, Natural Resources Institute.

Hard B., Friedrich S. & Babel W. (1997). Bioremediation of acid mine water using facultative methylophilic metal-tolerant sulphate-reducing bacteria. Microbiology Research, 152, 65–73.

Hedin R.S. (1994). The effects of anoxic limestone drains on mine water chemistry. In: Volume 2 of Proceedings of the International Land Reclamation and Mine Drainage Conference and the Third International Conference on the Abatement of Acidic Drainage, 24–29 April. Pittsburgh, PA:

Hedin R.S., Watzlaf G.R. & Nairn R.W. (1994). Passive treatment of acid mine drainage with limestone. Journal of Environmental Quality, 23, 1338-1345.

Hellier W. W. & Hedin R. S. (1992). The mechanism of iron removal from mine drainages by artificial wetlands at circumneutral pH. INTECOL'S IV International Wetlands Conference Abstracts, Columbus, OH.

Henrot J. & Wieder R.K. (1990). Processes of Fe and Mn retention in laboratory peat microcosms subjected to acid mine drainage. Journal of Environmental Quality 19: 312-320

Huntsman B.E., Solch J.B. & Porter M.D. (1978). Utilization of a Sphagnum species dominated bog for coal acid mine drainage abatement. Abstracts, 91st Annual Meeting Geologic Society America, Ottawa, Ontario, Canada.

Ignazi J.C. (1993). Improving nitrogen management in irrigated, intensely cultivated areas: the approach in France. In: Prevention of water pollution by agriculture and related activities, pp. 247-261, Proceedings of the FAO Expert Consultation, Santiago, Chile, 20-23 October. Rome: FAO.

Jakubick A. & McKenna G. (2003). Stabilisation of tailings deposits: International experience. Mining and the Environment III, Sudbury, Ontario, Canada, 25-28 May. pp. 1-9.

Jones D.R. & Chapman B.M. (1995). Wetlands to treat AMD: Facts and fallacies. In: N.J. Grundon & L.C. Bell (Eds), Proceedings of the Second Annual acid mine drainage workshop, pp. 127-145, 28-31 March, Publisher Charter Towers, Queensland, Australia.

Kamrin M. (1995). Environmental hormones. http://www.oes.orst.edu:70/1/ext_select_EXTOXNET. (Accessed 14-09-2007)

Karr J.R. & Dudley D.R. (1981). Ecological perspectives on water quality goals. Environmental Management, 5, 55-68.

Kempster P.L. & Smith R. (1985). Proposed aesthetic/physical and inorganic drinking water criteria for the Republic of South Africa. Research Report No. 628, National Institute for Water Research. Pretoria: CSIR.

Kleinmann R.L.P. (1991). Biological treatment of mine water: An overview. In: Proceedings of the Second International Conference on the Abatement of Acidic Drainage, MEND, 1991, Montreal, Canada.

Kotze D. C. (1996). An introduction to wetland hydrology, soils and landforms. Report submitted to the Water Research Commission, Pretoria, for publication

Kotze D. C. & O' Conner T. G. (2000). Vegetation pattern within and among palustrine wetlands along an altitudinal gradient in KwaZulu-Natal, South Africa. *Plant Ecology*, 146 (1), 77-96.

Kotze D.C. (2004). Guidelines for managing wetlands in forestry areas. Mondi Wetlands Project. Water Research Commission, Pretoria

Kwong Y.T.J. & Van Stempvoort D.R. (1994). Attenuation of acid rock drainage in a natural wetland system. In: C.N. Alpers & D.A. Blowes (eds.), *The environmental geochemistry of sulphide oxidation*, pp. 382-392. Washington, (U.S.A.): American Chemistry Society.

Lawrence A.R. (1986). Impact of agriculture on groundwater quality in Kalpitiya, Sri Lanka. *British Geological Survey*. Report WD/03/86/20. McGraw-Hill Book Company. New York

May J., Budlender D., Mokate R., Rogerson C. & Stavrou A. (1998). Poverty and inequality in South Africa. Durban, South Africa: Praxis Publishing.

Mazur R.E. (1995). African migration and appropriate housing responses in Metropolitan Cape Town. Draft Report. Cape Town: Western Cape Community-based Housing Trust.

MCMPR & MCA (2003). Strategic Framework for Tailings Management, Ministerial Council on Mineral and Petroleum Resources & Minerals Council of Australia. ISBN: 0642722439..

Michaud J.P. (1991). A citizen's guide to understanding and monitoring lakes and streams. Olympia, WA (USA): Washington State Dept. of Ecology, Publications Office (Publication. #94-149).

Midgley D.C., Pitman W.V. and Middleton B.J. (1994): Surface water resources of South Africa 1990; WRC Report No. 298/1/94, Water Research Commission, Pretoria.

Mittal H.K. & Morgenstern N.R. (1976). Seepage control in tailings dams. Canadian Geotechnical Journal, 12, 235-261.

Monteith J.L. (1985). Evaporation from land surfaces: Progress in analysis and prediction since 1948. In: Advances in evapotranspiration, pp. 4-12, Proceedings of the National Conference on Advances in Evapotranspiration, 16-17 December, Chicago, IL, USA. St. Joseph, MI: American Society of Agricultural Engineering.

Moshiri G.A. (Ed.). (1993). Constructed wetlands for water quality improvement. Boca Raton, FL: Lewis Publishers.

Noller B.N., Woods P.H. & Ross B.J. (1994). Case studies of wetland filtration of mine waste water in constructed and naturally occurring systems in Northern Australia. Water Science and Technology, 29, 257-266.

Parsons C.F. (1990). Cooke 1 water project report. Johannesburg, Technical Services Division, Geological Department, Research Unit.

Parsons M.L. (1981). Groundwater aspects of tailings impoundments, design and construction of tailings dams. Proceedings of a Seminar, November 6-7, 1980 in Golden, Colorado. Taylor & Francis

Pirner S.M. (1990). Mine waste management in South Dakota. In: Proceedings of the Fourth Western Regional Conference on Precious Metals and the Environment, Black Hills Section SME, 19-22 September. Lead, SD: Society for Mining Metallurgy and Exploration Inc. pp. 293-307.

Reddy K R. & Patrick W H. (1984). Nitrogen transformations and loss in flooded soils and sediments. CRC Critical Reviews in Environmental Control, 13, 273-309.

Reiff F.M. (1987). Health aspects of waste-water reuse for irrigation of crops. In: Proceedings of the Interregional Seminar on Non-conventional Water Resources use in developing countries, 22-28 April 1985, Series No. 22. New York: United Nations. pp. 245-259.

Rhoades J.D. (1993). Reducing salinization of soil and water by improving irrigation and drainage management. In: Prevention of water pollution by agriculture and related activities. Proceedings of the FAO Expert Consultation, Santiago, Chile, 20-23 October 1992. Water Report 1. Rome: FAO. pp. 291-320.

Ritcey G.M. (1989). Tailings management: Problems and solutions in the mining industry. Amsterdam (The Netherlands): Elsevier Science Publishers.

Rodhe W. (1969). Crystallization of eutrophication concepts in North Europe. Eutrophication, Standard Book Number 309-01700-9, 50-64. Washington D.C.: National Academy of Sciences.

Saff G. (1996). Claiming a space in a changing South Africa: The "squatters" of Marconi Beam, Cape Town. Annals of the Association of American Geographers, 86 (2), 235-255.

Sagardoy J.A. (1993). An overview of pollution of water by agriculture. In: Prevention of water pollution by agriculture and related activities. Proceedings of the FAO Expert Consultation, Santiago, Chile, 20-23 October 1992. Water Report 1. Rome: FAO. pp. 19-26.

Samuel D.E., Sencindiver J.C. & Rauch, H.W. (1988). Water and soil parameters affecting growth of cattails. In: Mine drainage and surface mine reclamation, Volume 1, Information Circular No. 9183. Pittsburgh, PA: U.S. Bureau of Mines.

Sather J.H. & Smith R.D. (1984). An overview of major wetland functions and values. Washington: Fish and Wildlife Service, United States Department of the Interior.

Sikora F.J., Behrends L.L., Brodie G. & Bulls M.J. (1996). Manganese and trace metal removal in successive anaerobic and aerobic wetlands. U.S. Army Environmental Center Environmental Technology Division Aberdeen Proving Ground, Maryland

Skaggs R.W., Breve M. A. & Gilliam J.W. (1994). Hydrologic and water quality impacts of agricultural drainage. Critical Reviews in Environmental Science and Technology. Page 17-18

Skovran G.A. & Clouser C. R. (1998). Design considerations and construction techniques for successive alkalinity producing systems. In: Proceedings of the 1998 Annual Meeting of the American Society for Surface Mining and Reclamation. St. Louis, MO: American Society for Surface Mining and Reclamation.

Stark L.R. (1990). A study of natural wetlands associated with acid mine drainage. AML research contract report, NTIS PB91176370. Arlington, U.S. Bureau of Mines.

Statistics South Africa (1997). The people of South Africa, population census, 1996: Census in brief. Pretoria: Statistics South Africa.

Sobolewski A. (1995). Development of a wetland treatment system at United Keno Hill Mines, Elsa, Yukon Territory, Proceedings of the Twentieth Annual British Columbia Mine Reclamation Symposium, Kamloops, British Columbia, p. 64-73.

Sur U. (2003). Identification/mapping of slum environment using IKONOS satellite data, Case Study: Dehradun, India. Unpublished report, Human Settlement Analysis Course. Tarutis (India): Indian Institute of Tarutis.

Tarutis W., Stark L. & Williams, F. (1999). Sizing and performance estimation of coal mine drainage wetlands. Department of Biology, 208 Mueller Laboratory, The Pennsylvania State University, University Park, PA 16802, USA

Tchobanoglous G., Burton F.L. & Stensel H.D. (2003). Wastewater Engineering (Treatment Disposal Reuse) / Metcalf & Eddy, Inc., 4th Edition, McGraw-Hill Book Company. New York

Van Zyl D.J.A., Hutchison I.P.G. & Kiel, J.E. (1988). Introduction to evaluation, design and operation of precious metal heap leaching projects. Littleton, CO: Society of Mining Engineers, Inc.

Vick S. G. (1990). Planning, design, and analysis of tailings dams. Vancouver, BiTech Publishers Ltd

Volpe R. & Kelly W.E. (1985). Seepage and leakage from dams and impoundments. American Society of Civil Engineers. Levy Place, New York

Walton-Day K. (1993). In Press. Iron and zinc budgets in surface water for a natural wetland affected by acidic mine drainage, St. Kevin Gulch, Lake County, Colorado. In:

Morganwalp, D.W. and D.A. Aronson (Eds). U.S. Geological Survey Toxic Substances Hydrology Program, proceedings of the technical meeting, Colorado Springs, Colo. September 20-24, 1993. U.S. Geological Survey Water-Resources Investigation Report 94-4015.

Water Quality Association (2000). An overview of home water treatment technologies. Fact Sheet. <http://www.des.state.nh.us/dwg.htm> access date: 11-08-2007

Watson J.T., Reed S.C., Kadlec R.H., Knight R.L. & Whitehouse A.E. (2000). Performance expectations and loading rates for constructed wetlands. In: D.A. Hammer (Ed.), *Constructed wetlands for wastewater treatment*, pp. 319-353. Chelsea, MI: Lewis Publishers.

Watzlaf G.R., Schroeder K.T. & Kairies C.L. (2002). Longterm performance of anoxic limestone drains. *Mine Water and the Environment, National Mine Land Reclamation; West Virginia Univ, Morgantown,*

Walkowiak D. (Ed.) (2006). Open channel flow measurement handbook, 6th ed. Water Resources, Publications, Littleton, Colorado

Wieder R.K. & Lang G.E. (1982.) Modification of acid mine drainage in a freshwater wetland. In: B.R. McDonald (Ed), *Proceedings of the symposium on wetlands of the unglaciated Appalachian region*, pp. 43-53. Morgantown, WV: West Virginia University.

Wildeman T., Gusek J. & Brodie G. (1991). Wetland design for mining operations. Draft handbook presented at the 1991 American Society for Surface Mining and Reclamation Conference, Pittsburgh American Society for Surface Mining and Reclamation.

Winde F., Wade P. & Van der Walt I.J. (2004). Gold tailings as a source of water-borne stream contamination, The Koekemoerspruit (Klerksdorp gold field, South Africa) as a case study, Part III of III: Fluctuations of stream chemistry and their impacts on mobility. Water SA, 30 (2), 233-240.

WHO (World Health Organisation) (1993). Health effects of the removal of substances occurring naturally in drinking water, with special reference to demineralized and desalinated water. Report of Brussels working group, Geneva, World Health Organization

Ziemkiewicz P.F., Skousen J.G. & Lovett R. (1994). Open limestone channels for treating acid mine drainage: a new look at an old idea. Green Lands, 24 (4): 36-41.

Zylstra A. (2005). 100-Year return period flood lines for the Wonderfonteinspruit from the Cooke Attenuation Dam outlet up to the Donaldson Dam. Unpublished report. Johannesburg. Johan Fourie & Associates and Harmony GM Co Ltd.

Appendix A

Wonderfontein Wetland Plant list (Cowan & Van Riet. 1998)

C2 Gramineae (Grasses)

- C2.1 *Imperata cylindrical*
- C2.2 *Setaria sphacelata*
- C2.3 *Pennisetum thunbergii*
- C2.4 *Hemarthria altissima*
- C2.5 *Paspalum urvillei*
- C2.6 *Paspalum dilatatum*
- C2.7 *Paspalum distichum*
- C2.8 *Andropogon appendicularis*
- C2.9 *Ischaemum fasciculatum*
- C2.10 *Arundinella nepalensis*
- C2.11 *Andropogon eucomis*
- C2.12 *Festuca caprina*
- C2.13 *Aristida junciformis*
- C2.14 *Eragrostis plana*
- C2.15 *Eragrostis planiculmis*
- C2.16 *Phragmites australis*
- C2.17 *Leersia hexandra*
- C2.18 *Miscanthus capensis*
- C2.19 *Miscanthus junceus*

C3 Cyperaceae (Sedges)

- C3.1 *Cyperus sexangularis*
- C3.2 *Cyperus latifolius*
- C3.3 *Cyperus fastigiatus*
- C3.4 *Cyperus marginatus*
- C3.5 *Fuirena pubescence*
- C3.6 *Kyllinga erecta*
- C3.7 *Scleria welwitschii*

C3.8 *Eleocharis dregeana*

C3.9 *Eleocharis limosa*

C3.10 *Schoenoplectus brachycerus*

C3.11 *Schoenoplectus corymbosus*

C4 Juncaceae (Rushes)

C5 Typhaceae (Bullrushes)

C5.1 *Typha capensis*

C6 Potamogetonaceae

(Pondweeds)

C6.1 *Potamogeton thunbergii*

C7 Asphodelaceae (Red-hot pokers)

C7.1 *Kniphofia species*

C7.2 *Kniphofia linearifolia*

C8 Amaryllidaceae (Vlei lilies)

C8.1 *Crinum species*

C8.2 *Crinum macowanii*

C9 Polygonaceae (Knotweeds)

C9.1 *Persicaria attenuata*

C10 Additional species form other families

C10.1 *Xyris capensis*

C10.2 *Satyrium hallackii*

C10.3 *Ranaculus multifidus*

C10.4 *Sium repandum*

C10.5 *Gunnera repandum*

C10.6 *Mentha aquatica*

Gramineae (Grasses)

All grasses have an open leaf sheath and stems with nodes, unlike sedges. The family includes wetland-dependant and non-wetland species.

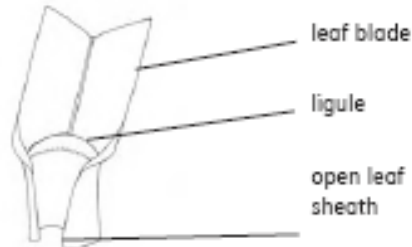

2.1 *Imperata cylindrical*

Strongly rhizomatous; leaves broad in the middle, narrow at tip, red in winter; inflorescence white; temporary wetness.



2.2 *Setaria sphacelata*

Rhizomatous or tufted; 0,3-1.5cm; inflorescence golden yellow; 7-40cm long; temporary and seasonal wetness leaf blade Ligule open leaf sheath



2.3 *Pennisetum thunbergii*

Tufted; 0.3-1.0m; inflorescence purple; 3-5cm long; temporary and seasonal wetness. *Pennisetum macrourum*: tufted; 0.4-1.5m; inflorescence light green; 12-25cm long; temporary and seasonal wetness.



2.4 *Hemarthria altissima*

Creeping; stoloniferous; leaves turn red; temporary and seasonal wetness.



2.5 *Paspalum urvillei*

Rhizomatous or tufted; 1.0-2.5m; inflorescence with 10-30 racemes on axis; conspicuous membranous ligule; temporary wetness.



2.6 *Paspalum dilatatum*

Rhizomatous or tufted; 0.3-1.3m; inflorescence with 4-9 racemes on axis; conspicuous membranous ligule; temporary wetness.



2.7 *Paspalum distichum*

Rhizomatous or stoloniferous (strongly creeping); <1.0m; inflorescence with a pair of racemes on end of stem; seasonal and permanent wetness.



2.8 *Andropogon appendicularis*
 0.3-1.2m; dense tuft; leaves folded;
 leaf bases flattened; temporary and
 seasonal wetness.

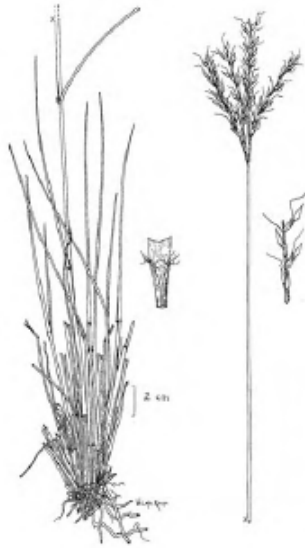

2.10 *Arundinella nepalensis*
 Rhizomatous; 0.6-1.5m; coarse,
 stiff-leaved with expanded blades;
 rigid inflorescence; temporary and
 seasonal wetness.



2.9 *Ischaemum fasciculatum*
 Rhizomatous; 0.3-0.9m; leaves
 light green turning reddish;
 common on edge of streams;
 seasonal to permanent wetness.



2.11 *Andropogon eucomis*
 Tufted; 0.2-0.9m; inflorescence
 with white silky hairs; temporary
 and seasonal wetness.



2.12 *Festuca caprina*

Tufted; 0.2-0.6m; leaves fine; old leaf bases persist as fine fibres; >1500m altitude; temporary and seasonal wetness.



2.14 *Eragrostis plana*

Tufted; 0.2-1.0m; flattened fan-shaped leaf base; leaves strong and smooth; temporary wetness.



2.13 *Aristida junciformis*

Densely tufted; 0.3-0.9m; leaves wirey, rolled and narrow; temporary and seasonal wetness.

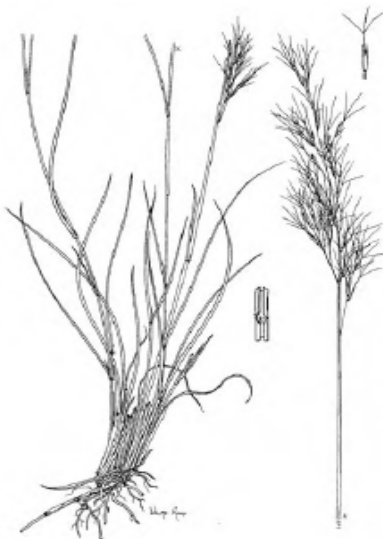

2.15 *Eragrostis planiculmis*

Resembles *Eragrostis curvula* but hairs absent from the base of the plant; inflorescence much branched; temporary and seasonal wetness.



2.16 *Phragmites australis*

0.6-4.0m; leaves break off at base
leave blade; usually permanent
wetness.

Phragmites mauritianus: resembles
Phragmites australis, but leaves
break off at base of the sheath and
have rigid sharp points; temporary
to seasonal wetness.



2.17 *Leersia hexandra*

Toothed ligule; tiny hairs on nodes;
temporary to seasonal wetness.

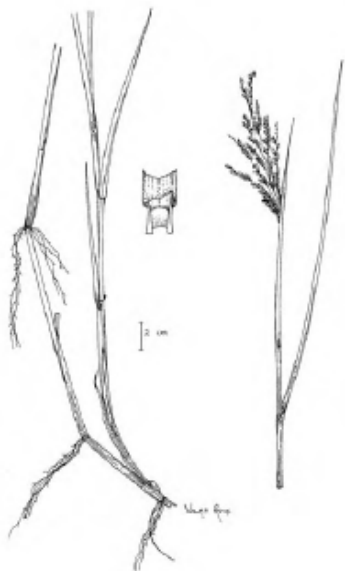

2.18 *Miscanthus capensis*

Tufted and robust; 0.5-2.5m; leaf
blades >1.0cm wide; distributions
generally south-east of Ladysmith;
temporary and seasonal wetness.



2.19 *Miscanthus junceus*

Tufted and robust; 0.5-2.5m;
resembles *Miscanthus capensis*
but leaf blades <0.4cm wide and
rounded; generally north-west of
Ladysmith; temporary to seasonal
wetness.



3 Cyperaceae (Sedges)

Sedges resemble grasses, but most sedges lack stem nodes. All sedges have a closed sheath, if present. Most of the species in the family are dependent on wetlands.

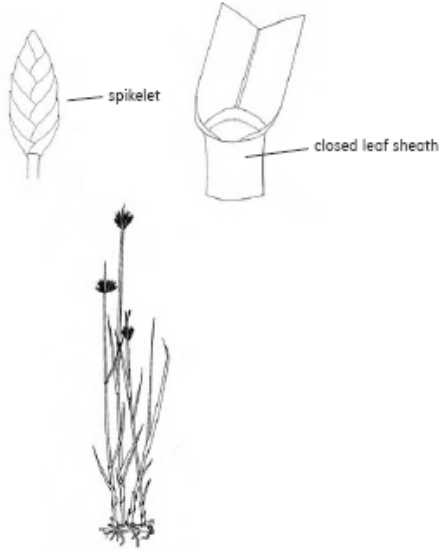

3.1 *Cyperus sexangularis*

Leaves absent, but several leaf-like bracts; surrounding inflorescence; stems 6-angled; rough textured; temporary and seasonal wetness. Spikelet closed leaf sheath

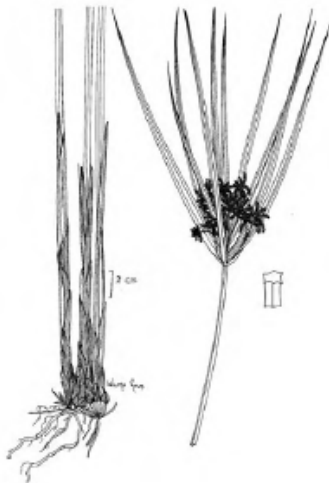

3.2 *Cyperus latifolius*

0.5-2.5m; robust plants; leaves stiff; usually >1cm wide; leaf margins smooth; seasonal and permanent wetness. *Cyperus dives*: resembles *Cyperus latifolius*, but leaf margins rough and readily cut one's finger; <900m altitude; permanent wetness.

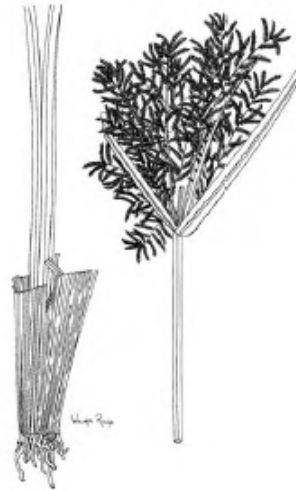

4 Juncaceae (Rushes)

Rushes characteristically have cylindrical stems and leaves. They may be confused with certain sedges (e.g. *Eleocharis* species and *Schoenoplectus* species) but their flowers are distinctly different. Most of the species in the family are dependent on wetlands. Florets with 6 stamens and 6 whorled bracts floret



Florets with 6 stamens and 6 whorled bracts



6 Potamogetonaceae (Pondweeds)

Submerged or floating leaved flowers in erect spikes. Most of the species in the family are dependent on wetlands.



5 Typhaceae (Bullrushes)

Inflorescence cigar shaped with leaves in a single plane. Most of the species in the family are dependent on wetlands.

7 Asphodelaceae (Red-hot pokers)
Inflorescence cigar shaped with
leaves in a single plane. The family
includes wetland-dependant and
non-wetland species.

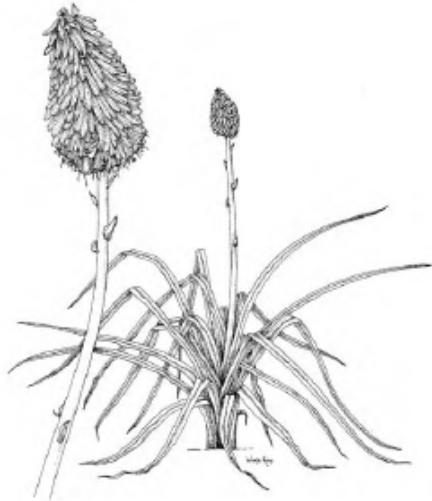

9 Polygonaceae (Knotweeds)
Base of the stem often swollen like
a knot and with a sheath. Flowers
in dry bracts. Most of the species in
the family are dependent on
wetlands. Persicaria (Polygonum)
species rely on seasonal and
permanent wetness.



8 Amaryllidaceae (Vlei lilies)
Submerged or floating leaved
flowers in erect spikes. The family
includes wetland-dependant and
non-wetland species.



