

**Comprehensive two-dimensional
supercritical fluid and
gas chromatography
(SFCxGC)**

By

Andre Venter

Submitted in partial fulfillment of the requirements for the degree
Doctor of Philosophy

In the

**Faculty of natural and agricultural sciences
University of Pretoria**

February 2003

Comprehensive two-dimensional supercritical fluid and gas chromatography (SFCxGC)

Submitted by

Andre Venter

In partial fulfillment of the requirements for the degree

Doctor of Philosophy

Supervisor : **Prof. E.R.Rohwer**

Department of Chemistry

Faculty of natural and agricultural sciences

University of Pretoria

Summary

A novel chromatographic method was devised that makes use of the superb group separation power of normal phase supercritical fluid chromatography (SFC) combined with a fast second separation by a resistively heated gas chromatograph (GC). The SFC was operated isothermally with stopped flow to provide the time required for the GC analysis. The GC analysis had a typical cycle time of 1 minute. During this time the GC column was independently heated at a rate of 450°C/min to 250°C and actively cooled down again to -50°C before the next GC injection takes place. This was achieved with an in-house designed, resistively heated, temperature programmable gas chromatograph. Various temperature measurement circuits were also evaluated. An interface was developed that allows transfer between the SFC and the GC in such a way that the entire eluent from the first separation is analyzed by the second separator. Chromatographic resolution was not lost during the transfer process from the first to the second separation stages. The interface also allows for the exchange of the carrier gas used in the second gas chromatographic separation to provide for the maximum separation speed. In the first separation, a silica gel packed column and the novel application of a silica gel porous layer open tubular capillary column was used for SFC group separation. The SFCxGC_{ftp} was applied to petrochemical samples and essential oils and the results were compared to that obtained with a commercially available GCxGC system.

Chapter 1 Introduction

1.1 Project history	1
1.2 Background	2
1.2.1 Chromatography in a nut shell	2
1.2.2 History	2
1.2.3 Modern Chromatography	3
1.2.4 Multidimensional Chromatography	4
1.2.5 Comprehensive multidimensional chromatography	5
1.3 Comprehensive supercritical fluid and gas chromatography	7
1.3.1 Comments on existing SFCxGC attempts	7
1.3.2 Advantages of SFCxGC _{ftp}	8
1.4 Approach	8
1.5 Presentation and arrangement	9

Chapter 2 Fundamental principles of comprehensive multidimensional chromatography

2.1 Multidimensional techniques	11
2.2 Multidimensional chromatography	11
2.3 Comprehensive Multidimensional Chromatography	12
2.4 Orthogonality	12
2.5 Resolution in two-dimensional chromatograms	13
2.6 Peak capacity of comprehensive multidimensional systems.	16
2.7 Sample dimensionality and Ordered Chromatograms:	20
2.8 Historical overview of multidimensional instrumentation	23
2.8.1 Thin layer chromatography	23
2.8.2 Planar column chromatography	23
2.8.3 Electrophoretic techniques	24
2.8.4 High performance liquid chromatography. HPLCxHPLC	24
2.8.5 Gas chromatography GCxGC	25
2.8.5.1 Modulators	25

2.8.5.2 Columns	26
2.8.5.3 Detection	27
2.8.6 SFCxGC	27
2.9 Chapter Conclusion	28

Chapter 3

Fast Gas Chromatography: Theoretical considerations

3.1 Introduction	29
3.2 Optimization of resolution for fast gas chromatography	31
3.3 Optimization of separation speed	35
3.3.1 The influence of capacity factor	36
3.3.2 The influence of selectivity	37
3.3.3 Influence of carrier gas flow rate and pressure drop	37
3.3.4 The influence of column radius	37
3.3.5 The influence of diffusion coefficients	38
3.3.6 The relative contributions of column diameter v/s carrier gas identity	39
3.4 Temperature programmed analysis	40
3.4.1 Heating rates	40
3.4.2 Normalized heating rates	41
3.4.3 Default Optimum Heating Rate	41
3.5 Achieving fast heating rates	42
3.5.1 Resistive heating	42
3.5.2 Methods of making columns electrically conductive	43
3.5.3 Methods of sensing temperature	44
3.5.3.1 Resistance measurements	45
3.5.3.2 Resistance measurement with superimposed AC signal	46
3.5.3.3 Separate sensing wire	46
3.5.3.4 Infrared temperature sensing	46
3.5.4 Temperature Control	46
3.5.5 The Control variable	46
3.6 Chapter conclusion	50

Chapter 4

Fast gas chromatography: Design, construction and evaluation

4.1 Introduction	51
4.2 Instrumentation.....	52
4.2.1 Column and electrical connections	52
4.2.2 Current Control	54
4.2.3 Temperature sensing.....	55
4.2.3.1 Philips circuit.....	56
4.2.3.2 Current mirror circuit	57
4.2.3.3 The Resistance Measurement Circuit.....	58
4.2.3.4 Thermocouple Measurements	59
4.2.3.5 Fixed current ramp	61
4.2.4 Data collection.....	61
4.2.5 Reproducibility.....	61
4.2.6 Optimization of rate	62
4.3 Results and discussion.....	62
4.3.1 General comments.....	62
4.3.2 Additional heating of injector and detector legs.....	64
4.3.3 The Philips circuit	65
4.3.4 The current mirror circuit.....	68
4.3.5 Resistance of heating element by Ohms' law	68
4.3.6 Thermocouples	71
4.3.6.1 Thermocouple basics.....	71
4.3.6.2 Very small thermocouples	72
4.3.6.3 Peak profiles in comparison to a stirred air bath GC	72
4.3.6.4 Thermocouple placement	73
4.3.6.5 Stability problems.....	75
4.3.7 Fixed function without feedback.....	75
4.3.8 Retention time reproducibility	75
4.4. Conclusions	81

Chapter 5

SFC: Theoretical considerations

5.1 Introduction	83
5.2 Supercritical fluids defined	84
5.3 Supercritical fluids as mobile phase in chromatography.....	85
5.3.1 Diffusion coefficients	86
5.3.2 Viscosity.....	86
5.3.3 Solvation	88
5.4 Parameters affecting retention in SFC.....	89
5.4.1 Density	90
5.4.2 Pressure.....	91
5.4.3 Temperature	92
5.5 Stationary phases used with SFC	94
5.6 Using phase ratio to reduce retention of oxygenates.....	94
5.7 Conclusions	97

Chapter 6

SFC: Demonstration of group separation

6.1 Introduction.....	98
6.2 Experimental.....	99
6.2.1 Instrumentation for packed column PAH group separation.....	99
6.2.2 Instrumentation for PLOT column separation.....	100
6.3 Results and discussion	101
6.3.1 Demonstration of the group separation of petrochemical samples using a silica gel packed column.....	101
6.3.2 Investigations into the group separation achieved with the PLOT column	102
6.3.2.1 PLOT column oxygenate elution pattern.....	102
6.3.2.2 The influence of temperature on group resolution.....	103
6.3.2.3 The influence of pressure on group resolution	104
6.3.2.4 Comments on flow rates and runtimes	105
6.3.2.5 Applications of the Silica gel PLOT column	107
6.4 Conclusions.....	109

Chapter 7

The Modulator: Background and literature survey

7.1 Introduction.....	110
7.2. The modulator.....	110
7.3 Stationary Phase Focusing.....	114
7.4 The sweeping arm thermal modulator.....	115
7.5 The Cryogenic Modulator.....	116
7.6 Diaphragm Valve Modulator.....	117
7.7 Non-mechanical modulators.....	117
7.7.1 Thermal modulation with hot and cold gas jets.....	117
7.7.2 Resistive multi-segmented thermal-gradient modulator.....	118
7.8 Conclusion.....	118

Chapter 8

The modulator: Design, construction and characterization

8.1 Introduction.....	119
8.2 Suggested modulator designs.....	120
8.2.1 Two-stage continuous modulator with pressure modulation.....	121
8.2.2 Stopped flow pressure modulation.....	122
8.3 Experimental.....	123
8.3.1 Hardware design.....	123
8.3.2 Demonstration of the interface.....	124
8.4 Results and Discussion.....	126
8.4.1 Number of modulation stages.....	126
8.4.2 Run time of the modulated 1 st dimension chromatogram.....	126
8.4.3 The influence of modulation on SFC flow rates.....	127
8.4.4 Advantages to the stopped flow interface.....	128
8.4.5 Influence of stopped-flow modulation on the SFC chromatogram.....	129
8.4.6 Modulation programming.....	130
8.5 Conclusions.....	130

Chapter 9

Demonstration of the comprehensive two-dimensional SFCxGC_{ftp}

9.1 Introduction	131
9.2 Experimental.....	133
9.2.1 The supercritical fluid chromatograph	133
9.2.2 The modulator	133
9.2.3 Resistively heated gas chromatograph	134
9.2.4 Description of the operation of the SFCxGC _{ftp}	136
9.2.4.1 Control before a run.....	136
9.2.4.2 Control during a run	137
9.2.4.3 Data collection and handling.....	137
9.3 Results and Discussion	138
9.3.1 Chromatograms obtained with the packed column	138
9.3.1.1 Analysis of a standard mixture	138
9.3.1.2 Analysis of a commercial petrol sample.....	141
9.3.1.3 Analysis of a diesel sample.....	143
9.3.2 Chromatograms obtained with the PLOT column.....	146
9.3.2.1 Analysis of a standard mixture of oxygenates.....	146
9.3.2.2 Analysis of an unleaded petrol sample	149
9.3.2.3 Analysis of a diesel sample(Natref LCO).....	149
9.3.2.4 Analysis of a lemon essential oil	153
9.4 Conclusions	153

Chapter 10

Conclusions

10.1 Group separation with SFC as a first separation dimension.....	154
10.2 Fast resistive heating for boiling point distribution in SFCxGC _{ftp}	155
10.3 The stopped flow pressure drop modulation interface	157
10.4 Advantages to SFCxGC _{ftp}	157
10.5 SFCxGC _{ftp} Applications	158

List of LabVIEW Programs

(Requires LabVIEW 5.1 or higher)

1. Fast GC Phillips circuit

a. Simple control.llb

- Run *simple control.vi*

b. Temperature calibration.llb

- Run *temperature calibration.vi*

2. Fast GC Resistive heating circuit

a. Simple control.llb

- Run *simple control.vi*

b. Temperature calibration.llb

- Run *temperature calibration.vi*

3. Fast GC with thermocouple

a. Fast GC.llb

- Run *fast GC.vi*

b. Simple control.llb

- Run *simple control.vi*

4. SFCxGC

a. SFCxGC.llb

- Run *SFCxGC1.vi*

5. Data compilation

- Run *columns-to-matrix.vi*
-

Acknowledgements

I would like to express deep gratitude to my supervisor, Professor Egmont Rohwer. Through your wise guidance, encouragement and support, I grew not only as a scientist, but also as a person.

Thank you, Mr. Tony Hasset for your continuous helpfulness, encouragement and patience. Without you, research in our labs would be much harder.

I would like to thank Mr. Gerrie Roos and Dr. Fanie vd Walt for your valuable contributions in explaining electronics and designing circuits.

Thank you, Fabian Muelburger for your help with the data compilation program.

Thank you, Peter Makgwane for watching over the machine and all your help.

And thank you, to all my colleagues, Dr. Collion Chen, Dr. Erla Harden, Alexander Whaley, Maria Fernandes-Whaley, Werner Welthagen, Emmanuel Zellelow who contributed in more ways than I can mention.

Thank you, Eugene Smit for editing the text.

This research was made possible thanks to grants from The Foundation for Research Development, financial support from SASOL and from Scientific Development and Integration (Pty) Ltd together with the THRIPP fund. I would like to express special thanks to SDI for providing a supportive work environment that allowed me to finish this thesis.

Chapter 1

Introduction

1.1 Project history

This thesis is a continuation of work that was submitted for a M.Sc. degree¹. The purpose of that project was to find an analysis method that would substantially reduce the time required to characterize petrochemical samples in the Sasol laboratories. The supercritical fluid chromatographic (SFC) analysis that was described therein could successfully separate the different groups found in light to middle distillate petroleum samples. The groups could also be quantified because it was possible to use the flame ionization detector (FID)². After SFC group separation, the groups were trapped on solid adsorbents and transferred off-line to a GC for subsequent boiling point analysis. The combination of SFC and GC analysis provided ample information for many applications.

Various problems were however encountered:

- The lengthy GC analysis times meant that some samples were only analyzed hours after sampling. This added additional uncertainties.
- Trapping times and duration was uncertain because of shifting in SFC retention times.
- The adsorbents used for the collection of SFC fractions produced background signals.
- Breakthrough of the more volatile components was encountered i.e. non-quantitative trapping of some compounds in the SFC fractions.

The study suggested that on-line transfer between the SFC and GC could alleviate many of these problems. Furthermore, if the two separation methods could be coupled comprehensively, a more complete picture of the sample properties would be obtained.

1.2 Background

1.2.1 Chromatography in a nutshell

In general chromatography is a physical method of separation in which the components to be separated are repeatedly distributed between two phases. One phase is stationary and the other moves through it, carrying the components in a particular direction. The chromatographic process occurs due to repeated sorption and desorption as the sample components are washed through the stationary bed. Separation occurs due to chemical or physical differences of the individual sample components, which influence their affinity for the stationary or mobile phases.

The information obtained from a chromatographic experiment is contained in the chromatogram. The chromatogram is a record of the concentration or mass profile as a function of the movement of the mobile phase in time, volume or distance. Information readily extracted from the chromatogram includes an indication of sample complexity based on the number of observed peaks, qualitative identification of sample components based on the accurate determination of peak position, quantitative assessment of the relative concentration or amount of each peak, and an indication of column performance.

1.2.2 History

Chromatography and similar separation methods have been in use since ancient times³. Some authors find the first reference to ion exchange in the Old Testament (Exodus xv. 22-25) while others believed that Aristotle knew about the adsorptive properties of some soils for the purification of seawater. Since the principles of these phenomena were not known, no further development in this field could take place. Bacon again described the purification of seawater with soils in the seventeenth century. The systematic study of these separation processes was only initiated in 1850 when Runge and several other workers independently started to study the separation of dyes on filter paper⁴. Way⁵ and Thompson⁶ discovered the fundamental principles of adsorption of cations from salt

solutions through different types of clay without realizing the significance of their observations.

The principals of adsorption chromatography was finally comprehended by the Russian scientist, Tswett, who correctly interpreted the previous observations and developed it into a reliable, sensitive and systematic method for separation of complex mixtures of even closely related chemical compounds⁷. Again Tswett's work was largely ignored until 1931 when it was 'rediscovered' by Kuhn et.al.⁸. Since then the art of chromatography has developed into the science we know today. From the first experiments using powdered calcium carbonate to separate green leaf extracts to the Nobel Prize awarded to Martin and Synge in 1952 for the invention of partition chromatography, samples of ever-increasing complexity could be analyzed.

New discoveries now occur at such a pace that there is hardly enough time to fully investigate and apply the existing technologies. However, some developments have really transformed the field. One of these giant leaps was the discovery of capillary columns in 1957 by Golay⁹. Despite the obvious advantages inherent to capillary columns it took many years before they were accepted for general use. This happened when fused silica capillary columns became readily available commercially in the early 1980's. Today, for newcomers to chromatography, capillary columns are synonymous with gas chromatography.

1.2.3 Modern Chromatography

A modern capillary column can easily produce 100 000 theoretical plates with a peak capacity of a 1000 or more. This means that if sample components would elute evenly, 1000 peaks could be observed side by side and resolved with unit resolution.

Unfortunately this is not the case, as compounds tend to elute in a random fashion from the column and frequently overlap. Giddings and Davis showed by using the statistical model of overlap¹⁰ that, to separate 98 out of 100 randomly eluting compounds, a system with 400 000 000 theoretical plates are required! As substantiated in Chapter 2, this translates into a peak capacity equal to 10 000 for non-programmed runs.

Real samples frequently contain far more than 100 compounds. Petrochemical or biological fluids may easily contain thousands of different compounds. Table 1 shows the number of possible paraffinic isomers per carbon number and the boiling point of the n-alkane^{11,12} for a limited carbon number range.

Table 1-1. Carbon number, boiling point and number of possible paraffin isomers.

carbon number	Boiling point n-alkane (°C)	number of isomers
5	36	3
8	126	18
10	174	75
15	271	4347
20	344	3.66×10^5
25	402	3.67×10^7
30	450	4.11×10^9
35	490	$4.93. \times 10^{11}$

Even for simple aliphatic hydrocarbons as illustrated in Table 1-1, the numbers are intimidating. For carbon numbers up to C12, more than 10 000 alkane, naphtene and aromatic structures are possible¹³. Most of these are likely to be present in a petroleum oil sample and may need to be analyzed for.

1.2.4 Multidimensional Chromatography

Unfortunately, single column gas chromatography fails even to analyze samples that contains as few as 150 to 250 relevant compounds¹⁴. In such cases the scientist has to apply to multidimensional chromatographic techniques. Often target analysis of only a handful of analytes is required. 'Sample clean up' is then used to remove relevant components from an interfering matrix or samples are pre-separated into fractions that can be analyzed with available separation capabilities. Sometimes a selected part of a chromatogram is cut from the column exit and subjected to a different kind of chromatographic separation. This can be done on-line or off-line and the technique is

referred to as heart cutting. Only a few cuts can generally be analyzed for every injection. When detailed analysis of complex samples such as petrochemical samples are required, these techniques become extremely time-consuming due to the number of injections required for each sample.

It is sometimes possible to analyze for target compounds in complex samples by using selective detection. Spectroscopic detectors can be set to detect the absorbance of UV or IR radiation at predetermined wavelengths where only specific compounds absorb electromagnetic energy. Mass spectrometers are also frequently used for selective detection. Here the mass analyzer is set to only transmit ions that have a particular mass-to-charge ratio. This is called single ion monitoring (SIM) mass spectrometry.

It is also possible to repeatedly scan through a range of electromagnetic frequencies or mass-to-charge ratios at every data point on the chromatogram. In the process a two dimensional analysis is obtained. Generally, when two analytical techniques are applied simultaneously to the analysis of a sample, it is referred to as a *hyphenated* technique.

1.2.5 Comprehensive multidimensional chromatography

A special case of multidimensional chromatography, called comprehensive multidimensional chromatography, has recently been developed.

Comprehensive multidimensional chromatography is a hyphenated technique where two or more chromatographic separations with different selectivity are coupled together. However, the analysis is far more complete than for heart cutting techniques, since the entire sample eluting from the first separation is analyzed by the second separation and because the resolution achieved in the first analysis is conserved throughout subsequent analysis steps¹⁰.

The total amount of information that can be obtained from a comprehensive multidimensional method is surprisingly high if the combination consists of completely independent techniques. Any correlation between the selectivities of the two separations, however, leads to the wasteful production of separation space that cannot be used¹⁵.

Ultimately this synentropy or cross-information¹⁶ leads to an increase in total analysis

time without an increase in information production. Separation mechanisms that are free from synentropy are said to be orthogonal to each other. In such a case the two separation dimensions produce a rectangular separation space with compounds distributed evenly across the plane.

The fundamental principles of comprehensive multidimensional chromatography have historically been applied to thin layer chromatography, electrophoretic techniques¹⁷ and high performance liquid chromatography (HPLCxHPLC)¹⁸. But comprehensive multidimensional chromatography caused relatively little excitement until the recent development of comprehensive two-dimensional gas chromatography (GCxGC)¹⁹.

A GCxGC instrument generally uses a non-polar column in the first dimension to separate samples according to volatility. Consecutive small sections of this chromatogram are refocused and introduced into a short polar column where each fraction is separated by differences in polarity. By using the same temperature ramp rate for the two columns, orthogonality is achieved by effectively removing the volatility aspect of the retention mechanism in the second column, leaving only the resultant polar interactions.

Selectivity in GC is always primarily a volatility separation. The number of GC stationary phases with additional selectivity is limited and most of these secondary interactions are weaker at high temperatures. This restrains the scope of GCxGC type analysis. Even so, this technique has proved to be very powerful for detailed analysis of complex samples. More than 6000 peaks have been observed for a kerosene sample²⁰. As was the case for capillary columns, it is once again the petrochemical industry that is the main driving force behind the advancement of GCxGC.

Attempts at combining HPLC with GC are hampered by the large amount of solvent that needs to be removed. This requires time and can lead to a loss of volatile sample components. Despite refinements in technology, even simple online HPLC-GC is seldom

accepted as a method of choice²¹. However, commercial instruments are available and the technique is used in practice. An example is the SRI LC-GC Combo system²². Conventional temperature programmed GC typically runs for about an hour and the oven requires time to return to the starting temperature. This is not fast enough to allow a potential an HPLCxGC analysis to be completed in a reasonable time.

1.3 Comprehensive supercritical fluid and gas chromatography

1.3.1 Comments on previous SFCxGC attempts

SFCxGC has been attempted using the same interface between the two columns that was used for GCxGC with essentially the same experimental conditions²³. These include the simultaneous temperature programming of both columns and approximately isothermal operation of the second column for the duration of each consecutive 2nd dimension chromatogram. This approach to SFCxGC does not utilize the full potential of supercritical fluid chromatography. Many of the available SFC selectivities such as polar, enantiomeric and size or shape separation are temperature sensitive. It would make sense to operate the SFC at low temperatures to increase these different modes of selectivity. However, to make full use of the GC and to circumvent the *general elution problem* it is required that the GC be operated in a temperature programmed mode.

Recent advances in fast programmable GC have brought turnaround times down to minutes or less, even for samples exhibiting relatively high complexity. This opens up a new avenue towards comprehensive multidimensional SFCxGC where a low temperature SFC separation is followed by a fast temperature programmed GC (GC_{ftp}) run for volatility analysis.

1.3.2. Advantages of SFCxGC_{ftp}

As demonstrated in the following chapters, there are many potential advantages to SFCxGC_{ftp} over GCxGC and existing SFCxGC approaches. These include:

1. There are a large variety of stationary phases available for SFC separation, which allow for improved selectivity for a variety of sample dimensionalities especially at low temperatures.
2. Only the temperature stable non-polar siloxane stationary phases are heated, allowing for samples with higher final boiling points to be analyzed than in GCxGC.
3. Due to the very fast heating rates, the GC column is at the higher temperatures for a very short time. Not only will the stationary phase last longer, but also thermally labile compounds that would usually not be observed with GC may be analyzed for²⁴, as most of the analysis time is spent in the low temperature SFC column.
4. Another potential advantage is that, for the first time, it would be possible to use the FID together with modifiers in SFC. The modifier can continuously be added to the SFC mobile phase as it will be separated from the analytes by the GC column before detection.

With these advantages in mind, a project was started to construct and evaluate a comprehensive two-dimensional supercritical fluid and fast temperature programmed gas chromatograph (SFCxGC_{ftp}).

1.4 Approach followed

For the first dimension a silica gel column with supercritical CO₂ as mobile phase was used for separation of sample components according to polarity.

For the second dimension, an in-house designed, resistively heated, temperature programmable gas chromatograph was used for volatility-based separation. The simplest case where the decompressed CO₂ from the SFC eluent stream was used as GC mobile phase was theoretically and experimentally investigated.

An interface between the SFC and GC was designed that allowed for the exchange of mobile phase for improved GC performance. As an example, flow modulation (stop-flow chromatography) was demonstrated to digitize the SFC separation, where loss in solvation strength due to depressurization of the SFC mobile phase, combined with a low starting temperature, served to focus the fractions on the GC column. The stopped flow version was easy to construct from a standard GC injector and a stop flow valve and excellent results were obtained with it. The continuous flow version was not constructed as part of this study, however the operation and principles were outlined shortly for future investigation. The stop-flow modulator was used for all SFCxGC_{ftp} experiments presented in this thesis.

1.5 Presentation and arrangement

In Chapter 2 the basic principles and ideas behind comprehensive multidimensional chromatography are explained. This chapter includes topics such as the current state of development of comprehensive multidimensional chromatography, the statistical model of overlap, sample dimensionality, orthogonality, modulation etc.

In Chapter 3 theoretical aspects pertaining to fast GC analysis and resistive heating are explored for use as the second dimension volatility separation. In Chapter 4, the construction of a novel fast temperature programmable gas chromatograph is described. The different electronic circuits that were constructed for controlling the resistively heated GC column are compared. Although it represents a large portion of the effort that went into the project, the reader can skip this part (section 4.2 and 4.3 up to 4.3.6) without losing track of the bigger theme. This section also demonstrates that a micro-thermocouple can be used with great success for temperature control of resistive GC's.

The basic principles of supercritical fluid chromatographic analysis are discussed in Chapter 5. Chapter 6 demonstrates group separation on normal phase SFC columns. A silica gel packed column was used for separation of petrochemical mixtures into the aliphatic, mono-, di-, and tri- aromatic compounds classes.

Chapter 6 also contains the novel application of a Silica PLOT column for the SFC group separation of various oxygenated compound classes in petrochemical mixtures and herbaceous essential oils.

Chapter 7 reviews some of the modulator designs found in the literature, while in Chapter 8, the design of a novel interface that allowed for the connection of SFC separation methods to fast resistive GC for comprehensive two-dimensional SFCxGC_{ftp} is described.

Demonstration of comprehensive two-dimensional SFCxGC_{ftp} is presented in Chapter 9. Chapter 9 also includes a comparison between chromatograms obtained with the SFCxGC_{ftp} and a commercial GCxGC instrument.

A summary of results together with recommendations for further research is presented in the concluding Chapter 10.

Chapter 1

- ¹ A.Venter, Supercritical fluid chromatography combined with GC and GC-MS for the analysis of complex petrochemical mixtures, M.Sc Thesis, (1998) University of Pretoria, South Africa
 - ² A.Venter, E.R.Rohwer, J.Chomatogr. A847 (1999) p309
 - ³ O.Mikes, Laboratory handbook of Chromatographic methods, D van Nostrand Company Ltd., London (1961) p14
 - ⁴ I.M.Hais, K.Macek. Papirova Chromatografie, CSAV, Prague (1959)
 - ⁵ F.T.Way, J.Roy.Agr.Soc. 11 (1850) p68
 - ⁶ H.S.Thompson, J.Roy.Agr.Soc. 11 (1850) p313
 - ⁷ M.Tswett, Berichte der Deutschen botanischen Gesellschaft 24 (1906) p385
 - ⁸ R.Khun, A.Winterstein, E.Lederer, Z.Physiol.Chem. 197 (1931) p141
 - ⁹ L.Ettre, LCGC 19 (2001) p48
 - ¹⁰ J.C.Giddings, In Multidimensional Chromatography; Techniques and Applications, H.J.Cortes (ed.), Marcel Dekker, New York (1990) p1
 - ¹¹ K.H.Altgeld, M.M.Boduszynski, Composition and analysis of heavy petroleum fractions, 1994, Marcel Dekker, Inc., New York, USA
 - ¹² J.Beens, Chromatographic couplings for unraveling oil fractions, Ph.D. Thesis (1998) University of Amsterdam, The Netherlands
 - ¹³ J.C.Giddings, In Multidimensional Chromatography; Techniques and Applications, H.J.Cortes, (ed.), Marcel Dekker, New York (1990) p119
 - ¹⁴ J.B.Phillips, J.Beens, J.Chromatogr. 856 (1999) p331
 - ¹⁵ C.J.Venkatramani, J.Xu, J.B.Phillips, Anal Chem 68 (1996) p1486
 - ¹⁶ F.Erni, R.W.Frei, J.Chromatogr. 149 (1978) p561
 - ¹⁷ J.W.Jorgenson, P.Marshall, New directions in electrophoretic methods, American Chemical Society, Washington (1987)
 - ¹⁸ Bushey M.M., Jorgenson J.W., Anal.Chem. 62 (1990) p161
 - ¹⁹ Z.Lui, J.B.Phillips, J.Chrom.Sci. 29 (1991) p227
 - ²⁰ C.J.Venkatramani, J.B.Phillips, J.Microcol.Sep. 5 (1993) p511
 - ²¹ K.Grob, J.Chromatogr A 892 (2000) p407
 - ²² SRI Instruments Catalog (2001) p88
 - ²³ Z.Lui, I.Osrtovsky, P.B.Farnsworth, M.L.Lee, Chromatographia 35 (1993) p567
 - ²⁴ S.Dagan, A.Amirav, Int.J. Mass Spectrom. Ion. Processes 133 (1994) p187
-

Chapter 2

Fundamental principles of comprehensive multi-dimensional chromatography

2.1 Multidimensional techniques

The term *multidimensional separation* refers to the combined use of different separation mechanisms to resolve components in complex mixtures. Possible combinations include separation methods such as simple solvent extraction, the different chromatographic mechanisms and electrophoretic techniques. In theory, any physical or chemical selective technique available to the separation scientist can be used to develop a multidimensional system.

2.2 Multidimensional chromatography

In multidimensional chromatography, fractions from a chromatographic system are transferred to one or more additional chromatographic separation systems to improve resolution and sensitivity or to decrease analysis time. This is sometimes referred to as *coupled column chromatography*, but generally the term *heart cutting* is used. With this technique, a selected portion of a chromatogram is transferred to another column that operates according to a different separation mechanism. Simmons and Snyder first demonstrated this in 1958. Since the ingenious invention of valveless pressure switching

by Deans¹, it became possible to collect fractions without fear of reactive sample components absorbing on valve materials. This technique works very well for target analysis. Only a few cuts can generally be made from the first separation. If many cuts or two cuts eluting close together are to be analyzed, re-injection of the same sample is normally required. In cases where the entire matrix needs to be analyzed, as often happens in the petrochemical industry, this system is extremely tedious and time consuming.

2.3 Comprehensive Multidimensional Chromatography

Comprehensive multidimensional chromatography is a special case of multidimensional chromatography. Here, the second column analyzes the entire sample. The initial resolution is conserved by sampling many times across every peak eluting from the first column. The repetitive 2nd dimension analysis represents a two dimensional separation with its injection time corresponding to the elution time of the first chromatogram. Integration of the 2nd dimension gives a data point that can be used to recreate the original one-dimensional chromatogram. This is analogous to the total ion chromatogram obtained from a GC-MS analysis². This digitizing of the first chromatogram is achieved with a modulation device. The modulator samples and often refocuses a small fraction of the first chromatogram, which the second column analyzes in the same time slot in which the modulator collects the next fraction.

2.4 Orthogonality

Multidimensional separations are only effective when unrelated selectivity mechanisms are involved in the different separation stages. When the mechanisms are completely different and independent the components are widely distributed across a plane (See Figure 2-1,A). For each component of a sample, two retention time values are generated, one for each dimension. Two such separations are said to be orthogonal³. The word

¹ D.R.Deans, *Chromatographia*, 1 (1968) p18

² P.J.Schoenmakers, et.al. *J.Chromatogr.A.* 892 (2000) p29

³ C.J.Venkatramani, J.Xu, J.B.Phillips, *Anal.Chem.* 68 (1996) p1486

orthogonal originates from the right angles of the plane that describes the generated separation space. Any correlation between the two dimensions tends to degrade this right angle. At the point where correlation is 100% all the compounds are once again distributed on a single line – the diagonal across the plane (See Figure 2-1, C).

Generating inaccessible peak capacity wastes time and reduces the efficiency of the multidimensional system. Minimizing the synentropy or cross-information between the separation dimensions maximizes information production.

Figure 2-1: Separation space utilization by orthogonal and correlated mechanisms

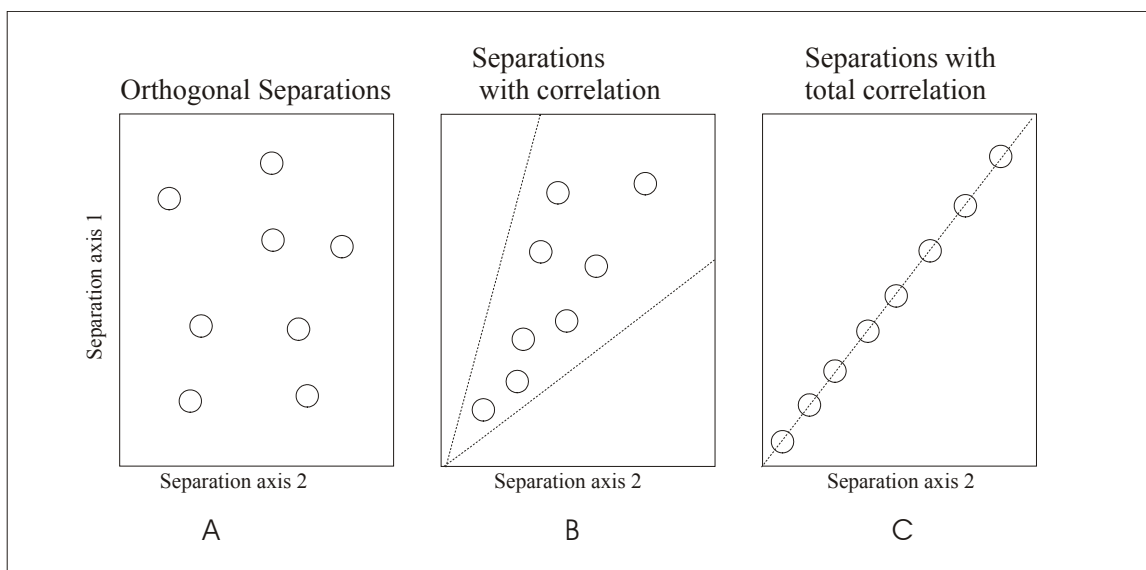

2.5 Resolution in two-dimensional chromatograms

Some of the definitions for one-dimensional separations need to be extended to cater for the additional complexity of multidimensional separations. Preferably, terms already developed in chromatography should be extended to include all cases of chromatography. One such term is resolution.

There are many ways to express chromatographic resolution, as discussed in detail in Chapter 3.2. In practice, resolution in a one-dimensional separation is often measured with: $R = \Delta t / 4\sigma$. Δt is the difference in the retention time maxima of two components. σ is the average standard deviation of two Gaussian peaks. When R is larger than 1, the

difference in retention time (Δt) is larger than the peak broadening (the standard deviation term) and peak spacing is adequate to observe two distinct component zones. When R is less than 0.5, peaks are completely fused and with R larger than 1.5 the peaks are completely (baseline) resolved. This definition has been extended to the two-dimensional case.

Two treatments of the resolution for two-dimensional bivariate Gaussian zones have been proposed^{4,5,6}. However, Schure showed both treatments to be equivalent when the zone broadening for two adjacent peaks are equal in both dimensions⁷.

The distance between two spots on a plane, δr , is given by the Pythagorean expression (see Figure 2-2)

$$dr = \sqrt{dx^2 + dy^2} \quad [\text{eq2-1}]$$

Figure 2-2: Cartesian, or Euclidean plane showing the Pythagorean relation

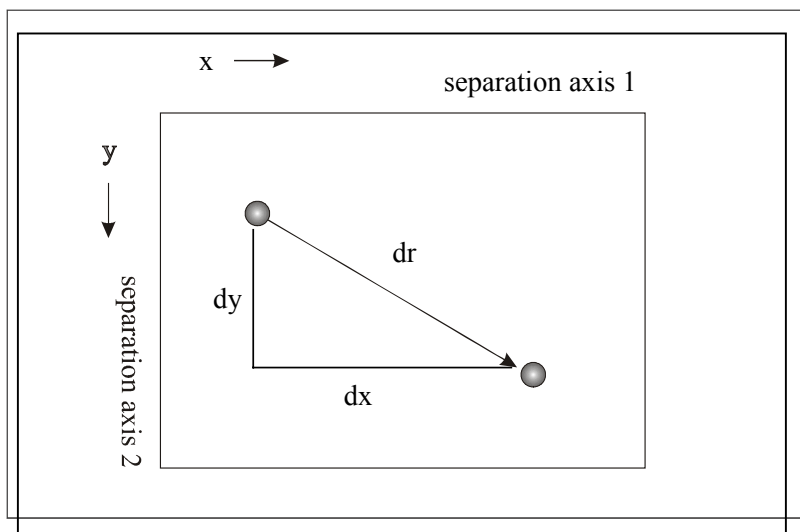

⁴ J.C.Giddings, in *Multidimensional Chromatography*, H.J.Cortes (ed.), Chromatographic Science series, vol 50, Marcel Dekker, New York (1990) p1

⁵ J.M.Davis, *Anal.Chem.* 63 (1991) p2141

⁶ W.Shi, J.M.Davis, *Anal.Chem.* 65 (1993) p482

⁷ M.R.Scure, *J.Microcol. Sep.* 9 (1997) p169

Differential displacement as well as 2D zone broadening determines resolution in two dimensions. If the separation along either axis is large enough to overcome zone broadening and yields good resolution, the separation cannot be undone by any displacement, positive or negative, in the other axis.

The resolution evolving along each one-dimensional axis is:

$$R_1 = dx / 4\sigma_1 \quad \text{and} \quad [\text{eq2-2}]$$

$$R_2 = dy / 4\sigma_2 \quad [\text{eq2-3}]$$

Applying the Pythagorean relation the resolution in two dimensions is:

$$R_{2D} = \frac{dr}{4\sigma} = \sqrt{\left(\frac{dx}{4\sigma}\right)^2 + \left(\frac{dy}{4\sigma}\right)^2} \quad [\text{eq 2-4}]$$

σ , the mean standard deviation along the line that connects the two centers, can be approximated by the average of σ_1 and σ_2 . This is especially true for spherical zones.

$$R_{2D} = \sqrt{R_{s1}^2 + R_{s2}^2} \quad [\text{eq2-5}]$$

Using this equation, it is simple to derive a method for determining R_{2D} ^{7,8} using the easy to measure 'peak to valley ratio', P , defined as

$$P = \frac{f}{g} \quad [\text{eq2-6}]$$

As shown in Figure 2-3, f is the difference between the amplitude at the valley, h , and the average peak maximum, g . Assuming that peaks are Gaussian, the two-dimensional resolution can also be calculated as^{7,8}.

⁸ R.E.Murthy, M.R.Schure, J.P.Foley Anal.Chem. 70 (1998) p1585

$$R_{2D} = \sqrt{-\frac{1}{2} \ln\left(\frac{1-P}{2}\right)} \quad [\text{eq2-7}]$$

Figure 2-3: Schematic diagram of the two-dimensional resolution measurement using a 2-dimensional contour plot and the corresponding slice for resolution determination.

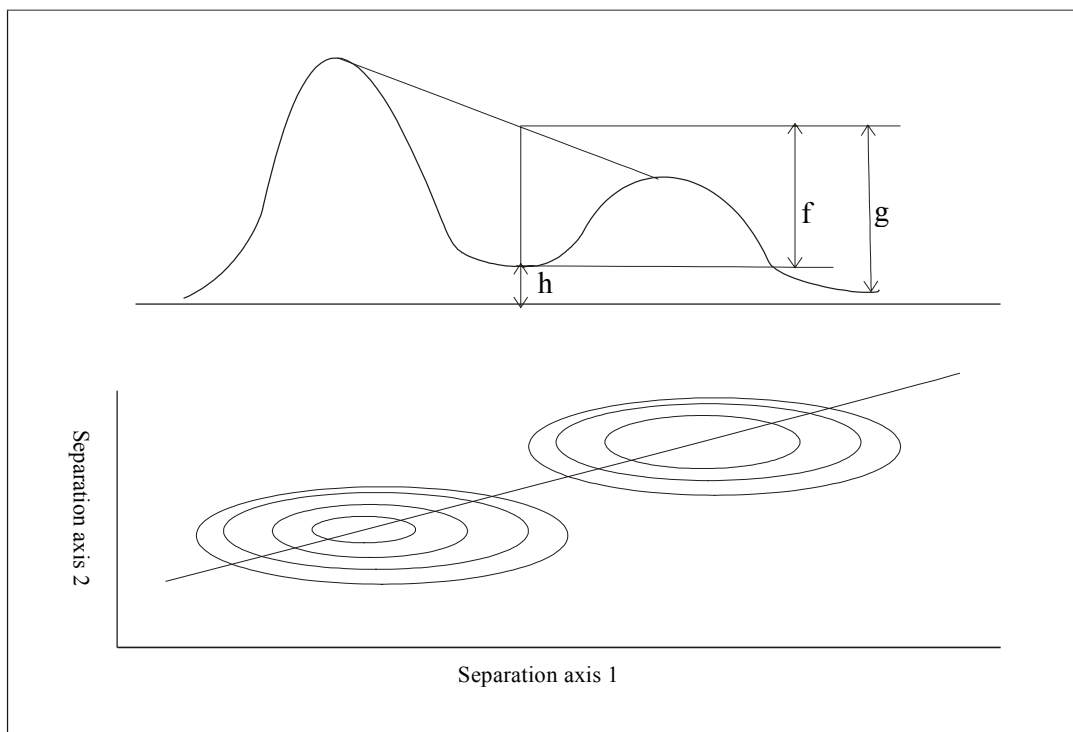

2.6 Peak capacity of comprehensive multidimensional systems.

The powerful separation capabilities of one-dimensional column chromatography are often inadequate when it comes to the analysis of complex samples^{9,10}. As the number of components increase, a drastic increase in plate count is necessary to resolve all the components of a complex sample. Giddings developed a mathematical model to illustrate the limitations of one-dimensional chromatographic systems⁴.

⁹ G.Guiochon, J.Chromatogr., 185 (1979) p3

¹⁰ G.Guiochon, A.M.Siouffi, J.Chromatogr., 245 (1982) p1

He formulated the overall resolving power of a linear column in terms of the peak capacity n_c . The peak capacity is defined as the maximum number of peaks that can be resolved side by side into the available separation space. For non-programmed runs, peak capacity is related to the number of theoretical plates (N) by:

$$n_c = \phi N^{1/2} \quad [\text{eq2-8}]$$

where ϕ depends on the retention time range or available separation space.

At first glance it would appear as if a column can separate any number of components, m , as long as $m \leq n_c$. This is true as long as all peaks are evenly distributed in the available separation space, filling the entire available space by separated peaks. Unfortunately this is rarely the case. Peaks are randomly distributed over the chromatogram and often overlap. The situation can be improved by ensuring that the number of components in the sample is much smaller than the peak capacity of the column. $n_c \gg m$. In practice, the available plate numbers severely limit the number of randomly eluting peaks, m , that can be resolved in a one-dimensional chromatographic run. Using the Statistical Model of Overlap (SMO)¹¹, Giddings estimated the need for an astounding 400,000,000 plates if 98 out of 100 randomly eluting compounds are to be separated⁴ by one-dimensional chromatography.

Multidimensional systems provide an alternative method for increasing n_c . Separation by two independent, orthogonal retention mechanisms produces a retention plane. The peak capacity of the retention plane is the product of the peak capacities of the individual columns. If both columns can resolve 100 evenly spaced components then the system has a total peak capacity of $n_c = 10^4$ and the system can separate 98 out of 100 randomly eluting compounds. According to Giddings⁴ only 40,000 plates are required in a two-dimensional system to generate a peak capacity of 100. A one-dimensional system would require 4×10^8 plates to achieve the same peak capacity of $n_c = 10^4$.

Due to peak broadening in both dimensions, components are present on the retention plane as two-dimensional ellipses (**Figure 2-4**). Thus the total peak capacity for an

¹¹ J.M.Davis, L.C.Giddings, Anal.Chem, 39 (1983), p418

orthogonal two-dimensional separation system comprising two orthogonal separation mechanisms is given by:

$$n_c = \frac{L_1 L_2}{ab} = n_{c1} n_{c2} \quad [\text{eq 2-9}]$$

Figure 2-4: Peak capacity on a retention plane

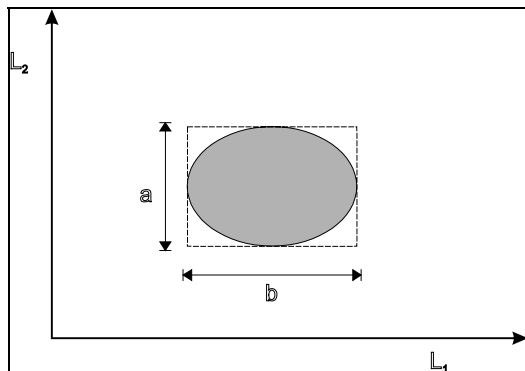

Where L_1 and L_2 is the separation space of the first and second dimension respectively (i.e. the total analysis time of each dimension) and ab is the area of the rectangle that circumscribes the ellipse on the separation plane. For spherical spots this is the number of spots that can be packed into a body centered cubic structure¹².

This equation holds for a multidimensional coupled column separator only if the number of transfers to a second column equals or exceeds the peak capacity of the first column. This ensures that the first dimension resolution is maintained. This approach is called comprehensive multidimensional chromatography (CMC).

In the case of heart cutting, where only selected cuts are transferred to secondary columns, the total peak capacity is equal to the sum of the peak capacities of the secondary columns. The contribution by the first dimension to the total peak capacity of the system is reduced to the number of cuts transferred to the second dimension.

¹² J.C.Giddings, HRC, 10 (1987) p319

$$n_c = \sum_{i=1}^k n_{ci} \quad [\text{eq2-10}]$$

If, for example, 6 cuts are transferred and analyzed sequentially on one secondary column, then the maximum gain in peak capacity is the sum of every transfer to the second column. $n_c = 6 \times n_{c2}$.

An alternative definition for peak capacity of a 2D chromatogram was put forward by Davis⁵. The peak capacity is defined as the ratio of the total area A of the chromatogram to the area A_0 required for the resolution of any zone.

$$n_{c,alt} = \frac{A}{A_0} \quad [\text{eq2-11}]$$

Peak capacity defined in this manner is related to the traditional n_c (eq2-9) for zones packed into a body centered cubic structure by a numerical factor: $\pi / 4$

$$n_c = \frac{\pi}{4n_{c,alt}} \quad \text{or} \quad n_c = 0.79n_{c,alt} \quad [\text{eq2-12}]$$

The advantage of defining peak capacity in this way is that a general theory, free from geometric factors that depend on zone distribution and bed shape, could be developed. This theory resembles the theory developed for 1-D separations in that both depend only on the expected number of components (m) and the *saturation* (λ) or the component density of the chromatogram ($\lambda = m / n_c$).

Even though the total peak capacity of a two-dimensional chromatogram is theoretically described as $n_{c(\text{total})} = n_{c1} \times n_{c2}$, in practice it is found that the ability to resolve peaks does not increase in direct proportion to the increase in peak capacity. Fewer peaks can be baseline resolved ($R=1.5$) in a two-dimensional separation than for the corresponding peak capacity in a one-dimensional separation.

Davis offered the following explanation⁵:

In a 1-D separation, in which the baseline width of a single component peak of standard deviation σ is $x_0 = 6\sigma$, one must provide x_0 units of component free space on both sides of the peak maxima to ensure baseline resolved peaks. Thus, two units of x_0 are required for each well-separated peak of width x_0 .

For a 2-D separation where the single component zone is $A_0 = \pi r^2$ one must provide with and an area $\pi(2r)^2$ of component free space, corresponding to the circle of overlap, to ensure that the zones are baseline resolved.

Thus, for every two component free widths required to achieve baseline resolved peaks in one dimension, four component free areas are required in two dimensions.

This does not contradict the fact that 2-D separations are better than 1-D separations. So much peak capacity is produced by a 2-D separation that one can afford to waste some of it through ineffective utilization of the peak capacity but still achieve better separation. 2-D separations also have the added advantage of producing ordered chromatograms.

2.7 Sample dimensionality and Ordered Chromatograms:

Giddings's Theorem¹³:

Given systematic variation in the molecular structures of a mixture of components, and dimensionality match between that mixture and its separator, the separation will be ordered.

It is evident that an increase in resolution of randomly eluting compounds is possible if the available separation space of a one dimensional line chromatogram is expanded to a plane by two orthogonal separation dimensions.

¹³ E.B.Ledford(Jr.), GcXGc: How it works and why, Presented at the ATAS Symposia Uk, Cambridge, May 1, 1997

An additional increase in information production can be achieved if the separation system is designed to elute components of a complex sample in a systematically ordered fashion. This calls for a selectivity correlation between the separation dimensions and the properties of the sample. For a truly ordered and unambiguous analysis, there need to be as many separation-dimensions as there are sample properties. Giddings¹⁴ suggested the term *sample dimensionality* (s) for the number of sample properties that defines a molecular entity. This means that the molecular identity of a component is fully established once the displacements along the n -dimensions of the separator are determined. $s = n$. Generally if two or more retention mechanisms are operative in a single chromatographic dimension, components will not be separated systematically and the separation pattern will appear chaotic. There are exceptions. As illustrated in Figure 2-5, if a sample property p_i is expressed weakly relative to p_j on a single dimension then apparent order might still be observed. Clusters of peaks separated by p_j will be grouped together by the stronger expression of p_i selectivity. This is called apparent dimensionality (s'). Ordered patterns can still be obtained even though $s < n$. For example, if on a column in one dimension, separation is conducted mainly by molecular weight but also to a lesser extent by shape, then a chromatogram looking like Figure 2-5 will be obtained. Separation need not always be attained by chromatographic separation. When a selective detector, like accurate mass mass-spectrometry is used, similar patterns may be observed in two-dimensions.

When only some of the sample dimensions are of interest, it may be required to analyze a sample along a selected few of the possible sample dimensions only. The required dimensionality (s'') is defined as the number of variables that must be determined for purposes of analysis. If all other sample properties are weakly expressed then the apparent sample dimensionality is equal to the required dimensionality. Thus if $s'' = s'$ a sample can be systematically analyzed in a system of $n = s''$ dimensionality. However these weaker dimensionalities may produce interesting secondary patterns in the resultant

¹⁴ J.C.Giddings, J.Chromatogr.A, 703 (1995) p3

chromatogram if they are expressed strong enough to produce some resolution but not so strong as to create a chaotic chromatogram.

Figure 2-5: Apparent dimensionality: Ordered patterns despite $s < n$.

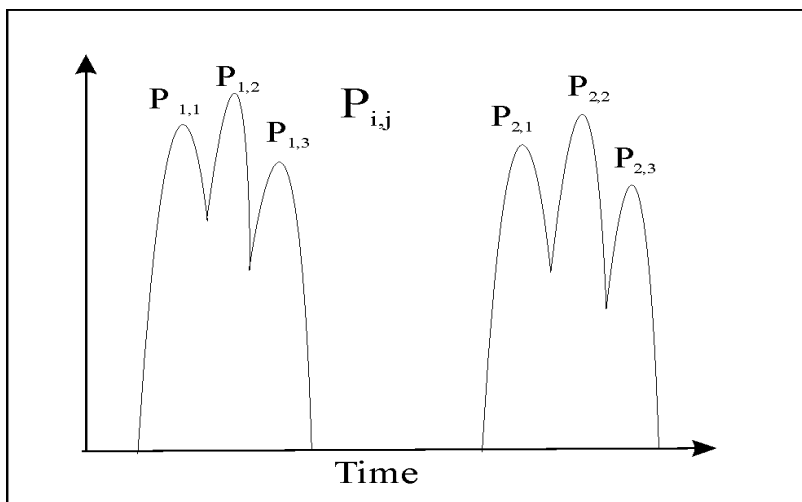

As an example of sample dimensionality, consider a sample containing only straight-chain n-alkanes. The components of the sample can completely be described with just one variable such as molecular mass or carbon number. This one-variable specification serves to define a one-dimensional sample. As long as separative displacement varies systematically with carbon number, an ordered chromatogram can be obtained with a system of adequate peak capacity. If we now choose to add an additional functionality to our sample, such as a double bond or one substituent group, the displacement along a single separation axis will exhibit a systematic, but unequal, dependency on both variables. Such a sample will require two separation dimensions where the displacements are independent or where the sample properties at least weigh differently in their effect on the two displacements. Extending the sample to include 0,1,2... different functionalities will require three dimensions and so forth⁴.

To achieve ordered chromatograms the number of separation dimensions must equal or exceed the sample dimensionality. The sample dimensionality is the number of independent variables needed to uniquely specify members of the mixture. The number of

dimensions required to produce an ordered chromatogram for any defined sample is limited because there are only so many possible independent chemical variables that can be defined. Soon any 'new' variables are likely to be strongly correlated with one or more previous variables¹⁵.

Some examples of possible chemical variables are:

- Dispersion forces responsible for volatility or molecular mass dimensionality,
- Dipole interactions,
- Pi-interactions - aromaticity,
- Hydrogen bonding e.g. oxygenated compounds,
- Size and shape e.g. for level of branching or cis/trans geometrical differences,
- Ion mobility,
- Chiral selectivity.

2.8 Historical overview of multidimensional instrumentation

2.8.1 Thin layer chromatography

To create a 2D TLC chromatogram, the sample is applied on a corner of the plate. The plate is then developed in one direction. After completion the plate is rotated 90° and developed using a different eluent to affect a different separation mechanism. It is extremely easy to implement 2D-TLC compared to other comprehensive 2D methods. However the limited peak capacity of a TLC plate means that $n_c \times n_c$ of 2D-TLC does not produce a very high number¹⁶. The orthogonality of a 2D TLC separation is also limited because the stationary phase is usually the same in both dimensions. Detection limits and quantitation of sample components with TLC is rather poor. Automation and re-use of separation medium is difficult.

¹⁵ J.B.Phillips, J.Beens, J.Chromatogr. A, 856 (1999) p331

¹⁶ G.Guiochon, M.F.Gonnord, A.Soufffi, M.Zakaria, J.Chromatogr., 250 (1982) p1

2.8.2 Planar column chromatography

This technique essentially employs the advantages of TLC but the peak capacity of the plate is increased by obtaining control over flow rate of the mobile phase. The bed is enclosed in a leak proof, pressure resistant container. Instead of relying on the capillary forces of the bed and surface tension of the mobile phase a pump is used to force a stream of solvent across the planar column. When the less retained components reach the edge of the bed, a different mobile phase is used in a perpendicular direction to separate the band with a different mechanism and distribute the sample components across the entire planar separation space. The major difference between planar column chromatography (also called multidimensional column chromatography) and TLC is that the compounds are eluted from the column as in HPLC and detected with a UV beam perpendicular to the thin solvent stream and focused on a diode array.

It has proved difficult to design a suitable detector for two-dimensional planar column chromatography. Furthermore the technique suffers from the same fundamental drawback as 2D-TLC: How to obtain orthogonal separation mechanisms while still using the same stationary phase in both dimensions¹⁷.

2.8.3 Electrophoretic techniques

Another example where compounds are separated by spatial dispersion is the multi-dimensional technique of SDS-PAGE combined with isoelectric focusing. This two-dimensional system gives the best resolution for the separation of complex mixtures of proteins. The separation utilizes two independent protein characteristics:

- The isoelectric point (pI) reflects the charge of proteins.
- Slab gel electrophoresis is then used with sodium dodecyl sulfate (SDS) in the second dimension^{18,19}. Here, the differences in molecular mass determine the relative mobility of the SDS-protein complexes in a polyacrylamide gel.

¹⁷ F. Geiss, Fundamentals of thin layer chromatography: planar chromatography, Huthig, (1987)

¹⁸ P.H.O'Farrel, J.Boil.Chem., 250 (1975) p4007

¹⁹ N.G.Anderson, N.C.Anderson, Anal.Biochem. 85 (1978) p331

Two-dimensional electrophoretic techniques are widely used in the field of biochemistry today.

2.8.4 High performance liquid chromatography. HPLCxHPLC

Three online multidimensional HPLCxHPLC systems were demonstrated in 1978²⁰, but only the system by Erni and Frei²¹ resembles comprehensive multidimensional chromatography. An 8-port valve with two sampling loops of the same size was used to perform repetitive sampling of the first column chromatogram. Because only a small number of cuts were transferred to the second column their system was not strictly comprehensive. Using a similar eight-port valve configuration, Bushey and Jorgenson demonstrated comprehensive two-dimensional HPLCxHPLC in 1990²². They coupled cation exchange to size exclusion columns for proteins analysis.

HPLCxHPLC is a complementary method to 2D gel electrophoresis for the analysis of proteins. This was demonstrated with a cation exchange column coupled to two reverse phase columns in parallel.^{23,24} While proteins with molecular weight <20 000 are difficult to separate with 2D-gel electrophoresis, the HPLCx HPLC method offered high-resolution protein separations. The total analysis time was less than 20 minutes. HPLC x HPLC separation schemes were also applied to the analysis of nitro, chloro and aminophenols²⁵, the analysis of organophosphorous and organochlorine pesticides²⁶ etc. Numerous articles have also been published to demonstrate comprehensive multidimensional LCxCZE for peptide analysis²⁷, for urine analysis²⁸ and other applications.

²⁰ E.L.Johnson, R.Gloor, J.Chromatogr. 149 (1978) p571

²¹ F.Erni, R.W.Frei, J.Chromatogr., 149 (1978) p561

²² M.M.Bushey, J.W.Jorgenson, Anal.Chem. 62 (1990) p161

²³ K.K.Unger et.al, HRC 23 (2000) p259

²⁴ K.Wagner et.al. ,J.Chromatogr.A, 893(2) (2000) p293

²⁵ A.P.Koehne, T.Welsch, J.Chromatogr.A, 845 (1999) p463

²⁶ R.W.Martindale, Analyst (London), 113 (1998) p1229

²⁷ M.M.Bushey, J.W.Jorgenson, Anal.Chem., 62 (1990) p978

²⁸ T.F.Hooker, J.W.Jorgenson, Anal.Chem., 69 (1997) p4134

2.8.5 Gas chromatography GCxGC

The late Prof. J.B. Phillips pioneered comprehensive two-dimensional GCxGC in the early 1990's^{29,30}. His initial work on multiplex chromatography³¹ - a form of chromatography where a sample is repeatedly injected - required the design of a modulator. The difference between multiplex chromatography and comprehensive multidimensional chromatography is that in the latter case the sample stream is continuously changing as a first chromatographic run develops. Instrumentation for comprehensive multidimensional gas chromatography in its simplest form consists of two columns coupled together with a modulator. A detector is connected to the exit of the second column and a series of chromatograms is produced. These are arranged into a two-dimensional matrix and presented graphically as a contour plot.

2.8.5.1 Modulators

The function of the modulator is to continuously sample the eluent from a first chromatographic column. The cuts are refocused and injected into a second column. It is the presence of the modulator that differentiates this technique from other multidimensional systems. By continuous sampling, the modulator effectively digitizes the first chromatogram. Each point on the chromatogram is expanded into a second chromatogram that provides information about a different sample dimensionality (e.g. polarity distribution) at that specific vapor pressure point or other sample dimensionality. A number of different modulation devices have been demonstrated using valves or stationary phase focusing. For stationary phase focusing both thermal³² modulators and cryogenic^{33,34,35,36,37} modulators have been used. These are essentially the same: With the

²⁹ J.B. Phillips, C.J. Venkatrami, *J. Microcol. Sep.* 5 (1993) p511

³⁰ J.B. Phillips, C.J. Venkatrami, US patents 5,135,549 and 5,196,039

³¹ M. Zhang, J.B. Phillips, *J. Chromatogr. A* 689 (1995) p275

³² E. Ledford et al, *HRC* 22 (1999) p3

³³ P.J. Marriott, R.M. Kinghorn, *Anal. Chem.* 69 (1997) p2582

³⁴ R.M. Kinghorn, P.J. Marriott, *HRC* 22 (1999) p235

thermal modulators a relatively thick film is often used for retention and the compounds are launched into the second column by supplying heat. With cryogenic modulators, designed by P.J.Marriot and his group, the compounds are retained in the interface by reducing the temperature when the coolant flow is switched off the interface quickly heats up to the temperature of the GC oven. The various modulator designs are discussed in detail in Chapter 7.

2.8.5.2 Columns

While any combination of columns with different mechanisms of selectivity can be used, the only practical arrangement for GCxGC is to use a non-polar column for volatility separation in the first dimension. A polar column is generally used in the second. This combination is ideally suitable for complex samples that often span a wide volatility range while the number of chemical classes that compounds can belong to is generally limited. The discrete nature of chemical functionality also implies that compounds are only distributed into a handful of groups or chemical classes when the molecular mass or volatility dimension is adequately suppressed. GCxGC is most useful when the second column can produce chromatograms faster than the first chromatogram generates peaks. Therefore the second dimension is an ideal high-speed GC application where each cut consists of only a few compounds of different chemical classes or polarities.

Volatility always plays the biggest part in GC retention mechanisms with secondary interactions such as polar interactions superimposed on this. Polar and chiral interactions are usually a strong function of temperature. The strength of these interactions decreases with an increase in temperature, which leads to a reduced selectivity at the higher analysis temperatures³⁸.

³⁵ R.M.Kinghorn,P.J.Marriott, HRC 21 (1998) p620

³⁶ R.M.Kinghorn, P.J.Marriott, HRC 21(1998) p32

³⁷ R.M.Kinghorn, P.J.Marriott,P.S.Dawes HRC 23 (2000) p245

³⁸ H.Rotzsche, Stationary phases in gas chromatography, J.Chromatogr. Library Vol.48, Elsevier (1991)p80

Despite the tremendous technical difficulty in coupling three columns together, Ledford successfully demonstrated 3D GC³⁹. However, it proved difficult to find GC columns significantly different in selectivity to beneficially apply comprehensive three-dimensional GCxGCxGC. Another way to address increased sample dimensionality was attempted by Sharpe et al. They split the effluent from the first column into two different columns in the second dimension. In the process, compound identification and separation efficiency were facilitated⁴⁰

2.8.5.3 Detection

The 2nd dimension column needs to be very fast to ensure that a transfer is completely analyzed before the next injection. This results in very narrow peaks requiring very fast electrometers. Until recently, standard electrometers on GC instrumentation were not fast enough to cope with peak widths in the 100-200 ms range. Most electrometers that are built into GC's contain low pass filters to remove high frequency noise and improve signal to noise ratios. Very fast changes in the signal can thus not be observed with these boards. Alternative electrometers had to be used or modifications to existing boards had to be made. Some modern instruments like the Agilent HP6890 series have been designed to cope with such fast peaks.

So far the flame ionization detector (FID) has primarily been used for GCxGC. There seems to be some disagreement⁴¹ in the literature about whether the many other detectors that are routinely used for GC can potentially be used for GCxGC¹⁴.

The use of mass spectrometry (MS) has provisionally been demonstrated⁴² using an ordinary quadrupole instrument. However it is only the time-of-flight (TOF) instruments that can produce the necessary minimum of six scans per peak to reconstruct total ion chromatograms for the fast peaks produced by the second dimension. State of the art

³⁹ E.B.Ledford, C.A.Billesbach, Q.Zhu, HRC, 23 (2000) p205

⁴⁰ J.V.Seeley, F.J.Kramp,K.S.Sharpe, J.Sep.Sci., 24 (2001) p444

⁴¹ W.Bertch, HRC, 23 (2000) p167

⁴² G.S.Frysinger, R.B.Gaines, HRC 22 (1999) p251

TOF's can produce up to 500 scans per second. It is hoped that computers will soon be able to handle the vast amount of data that will be produced by GCxGC-MS.

2.8.6 SFCxGC

Although early expectations were not all met, good applications have been developed with supercritical fluid chromatography (SFC) for chemical group separation using normal phase chromatography⁴³ and for enantiomer analysis⁴⁴.

Lee et al used the same technology developed for GCxGC namely the single stage thermal modulator as described in Chapter 7 to demonstrate comprehensive multidimensional SFCxGC⁴⁵. Two columns were placed in the same oven. Supercritical CO₂ was used for the first dimension and the expanded CO₂ after the restrictor was used as carrier gas in the second dimension. Due to slow diffusion coefficients, CO₂ is not a very good mobile phase to use when speed is important. A 50% cyanopropyl polysiloxane stationary phase was used as the first dimension to achieve group type separation based on the number of aromatic rings. In the second dimension a liquid crystal stationary phase was used to separate the groups further according to shape. Each of the second-dimension runs was essentially isothermal for its duration as in GCxGC. Hence the second dimension does not require conditioning for each next injection delivered by the thermal modulator. While strong on simplicity, the instrument limits the range of compounds that can be analyzed and leaves much desired for separation efficiency in the second column.

The instrument was applied to mixtures of poly-aromatic hydrocarbons and to a coal tar sample. Group type sample bands from the first column were separated into individual components on the second column. The entire sample passed through both columns and generated two sets of retention data, which could be used for more accurate compound identification.

⁴³ Annual Book of ASTM standards, vol.05.03, American society for testing and materials, Philadelphia (1991), Method D5186.

⁴⁴ K.E. Markides, M.L.Lee, SFC applications, Workshop on Supercritical Fluid Chromatography held in Park City, Utah, on January 12-14, 1988. Provo, Utah : Brigham Young University Press (1988)

⁴⁵ Z.Lui, I.Osrtovsky, P.B.Farnsworth, M.L.Lee, Chromatographia 35 (1993) p567

2.9 Chapter Conclusion

The theory behind comprehensive multidimensional chromatography is already quite advanced and the technique has been in use for many years in various embodiments. Yet the practical implementation of the technique is still hampered by the lack of reliable instrumentation, particularly as concerns the interface between the two dimensions. While many combinations of comprehensive chromatography have been demonstrated, the possibilities are far from exhausted. The combination of SFC and GC has not yet received the attention it deserves.

Chapter 3

Fast Gas Chromatography: Theoretical considerations

3.1 Introduction

Despite the tremendous decrease in analysis time that is possible with modern equipment, limited useful applications have been found for fast gas chromatography. Most often separation efficiency is sacrificed for a shorter run time. While shorter analysis times are desirable, the concurrent increase in complexity of instrumentation is unfortunate. Special low volume detectors and injectors¹ that are capable of producing very short injection bandwidths are required. Often the chromatographic run is a small part of the analysis scheme where much larger time expenses are made in sample preparation and data analysis. Thus it is not always wise to invest in new, complicated equipment when other factors dominate the total analysis and reporting time.

In the case of comprehensive multidimensional chromatography it is, however, paramount that the second separation should occur as fast as possible, since every 2nd dimension chromatogram is repeated many times. Any increase in 2nd dimension runtime is multiplied hundreds of times for each analysis. For a given 1st dimension runtime, the analysis of the 2nd dimension should also be fast enough to allow a great number of these to maintain the resolution of the 1st.

Normally fast GC alone is ineffective for detailed analysis of complex mixtures due to the limited peak capacity that can be generated. Because of the first separation, each transfer to the second column contains only a few compounds that can more readily be separated with the limited separation efficiency attainable with fast analysis.

Comprehensive multidimensional chromatography is thus an ideal application for very fast gas chromatography.

Retention mechanisms in gas chromatography are always dominated by volatility. There is an approximate exponential relationship between retention time and solute boiling point under isothermal GC conditions. When an intermediate temperature is chosen, the chromatogram is characterized by poor separation of early eluting compounds, a long analysis time and poor detectability of late eluting peaks due to band broadening. This is commonly referred to as *the general elution problem*. For mixtures of analytes exceeding a boiling point range of 100°C it is impossible to find a suitable analysis temperature. For these samples only programmed modes can achieve complete separation in good time. Both flow and temperature programming can be used. While linear temperature programming is most often used due to simpler experimental implementation, exponential flow programming offers many of the same advantages². There is a small chance that with modern electronic pressure control, flow programming may gain some popularity. However, with these instruments flow rates are still calculated and the accuracy depends on the precision to which column dimensions can be defined. Efficiency is sacrificed, as columns are used at optimum flow rates only for a short period during each run. Flow programming will never be able to cover the same wide spread in volatility as temperature programming.

Negative thermal gradients in distance have been applied to chromatographic columns as a form of moving focusing³. Cryogenic and retention gap focusing are usually single events before or on the head of the column. With negative thermal gradients across the length of the column the zones are continuously focused as they move towards the column exit while separation takes place. Because the inlet side of the column is at a higher temperature than the detector side, the rear of the band is at a higher temperature than the front and thus moves at a slightly higher velocity. This counteracts some of the chromatographic band spreading.

Unfortunately the same forces that make the zones narrower also move the zones closer together reducing the separation because the trailing zone is at a higher temperature than

the leading zone⁴. While it can be helpful in reducing the effects of non-ideal chromatographic conditions, gradient focusing can not increase resolution or speed of analyses beyond what is theoretically achievable with conventional temperature programmed analysis (PTGC) without gradient focusing⁵.

In comprehensive 2D gas chromatography, samples are first separated according to boiling point. Since all analytes in a specific transfer have the same volatility, isothermal chromatography can be used very successfully in the 2nd dimension. However, in our proposed comprehensive 2D SFCxGC the chemical class separation precedes the boiling point analysis and each subsequent transfer contains a wide boiling point range. It is therefore required that a wide boiling point range be analyzed in a very short time. To this end, the theory behind fast gas chromatography, especially that pertaining to programmed temperature analysis, is explored in this chapter.

3.2 Optimization of resolution for fast gas chromatography

The relation between the different chromatographic variables is demonstrated by the well-known resolution equation:

$$R = \frac{\sqrt{N}}{4} * \frac{k'}{k'+1} * \frac{\alpha - 1}{\alpha} \quad [\text{eq 3-1}]$$

where R_s is the resolution between two successive peaks, k' is the capacity factor of the most retained compound and $\alpha = k'_2/k'_1$ is the relative retention (also known as the selectivity).

The capacity factor is dependent on temperature through the thermodynamic partition coefficient, K , and the phase ratio, β .

$$K = \beta k' \quad [\text{eq 3-2}]$$

where

$$\beta = V_m/V_s \quad [\text{eq 3-3}]$$

with

V_m as the volume of the mobile phase

V_s is the volume of the stationary phase

and

$$K \propto e^{\frac{-\Delta\mu}{RT}} \quad [\text{eq 3-4}]$$

with

$\Delta\mu$ as the change in free energy.

Thus, according to equation 3-2 and 3-4 an increase in temperature will reduce the capacity factor, resulting in a decrease in resolution (through equation 3-1) as well as analysis time (equation 3-14).

For maximum resolution, conditions are chosen where the term $[k'/(k'+1)]$ in equation 3-1 approaches the maximum value. For large retention values this term approach 1.

Figure 3- 1: The maximum of the $[k'/(k'+1)]$ term.

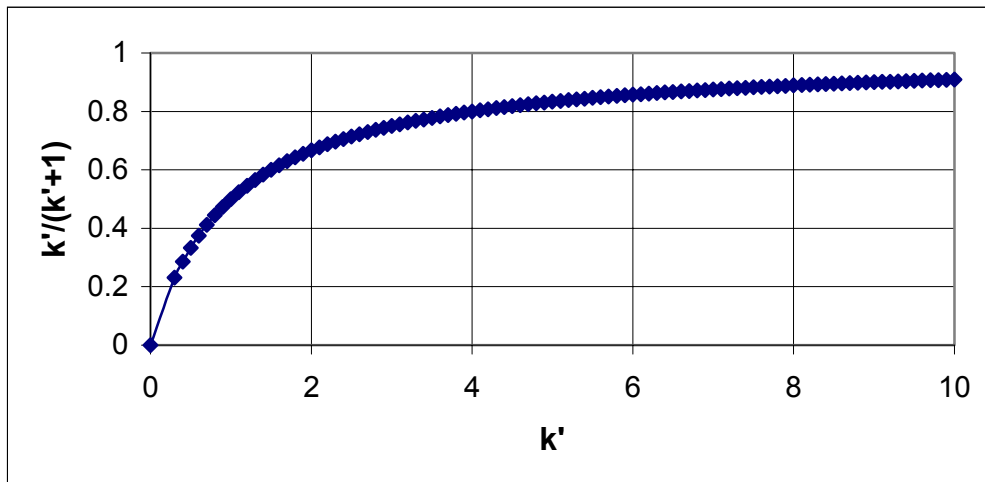

Resolution is measured experimentally from a chromatogram as

$$R = \frac{tr_2 - tr_1}{4\sigma} \quad [\text{eq 3-5}]$$

A resolution of $R > 1$ implies that the retention maxima of the two compounds differ more than the band broadening of the zone in time units. This is normally expressed in terms of

the standard deviation (σ). For a peak showing a gaussian profile, $R=1$ implies that the difference in retention time is equal to the width of the peak at base ($\Delta t_r = 4\sigma$).

The width of a peak is influenced by non-chromatographic factors such as the introduction width and by band broadening caused during the chromatographic process. The relative band broadening is expressed in terms of the theoretical plate height, H ⁷.

$$H = L \frac{\sigma^2}{t_r^2} \quad [\text{eq3-6}]$$

The relationship between H and u (the average linear velocity) for open tubular columns is given by the Golay-Giddings equation⁶:

$$H = \left[\frac{2D_m}{u} \right] f_1 + \left[\frac{(1 + 6k' + 11k'^2) r_c^2}{96(1 + k')^2 D_m} \right] f_1 u + \left[\frac{2}{3} \frac{k'}{(1 + k')^2} \frac{d_f^2}{D_s} \right] f_2 u \quad [\text{eq3-7}]$$

Where

D_m = diffusion of solutes in the mobile phase and

D_s = diffusion of solutes into the stationary phase.

$$- \quad f_1 = \frac{9(P^4 - 1)(P^2 - 1)}{8(P^3 - 1)^2} \quad [\text{eq3-8}]$$

$$- \quad f_2 = \frac{3(P^2 - 1)}{2(P^3 - 1)} \quad [\text{eq3-9}]$$

$P = p_i / p_o$ (the ratio between the column inlet and outlet pressures)

This can be simplified to

$$H = \frac{B}{u} + C_m u + C_s u \quad [\text{eq3-10}]$$

where B represents

- $B = 2D_m$ longitudinal diffusion

- $C_m = F(k) \frac{r_c^2}{D_m} f_1 u$ resistance to mass transfer in mobile phase

$$- \quad C_s = \frac{2}{3} \left(\frac{k'}{(k'+1)^2} \right) \frac{D_f^2}{D_s} f_2 u \quad \text{resistance to mass transfer in stationary phase}$$

and

$$- \quad F(k') = \frac{(1 + 6k' + 11k'^2)}{96(1 + k')^2} \quad [\text{eq3-11}]$$

A graphical presentation of plate height against linear flow rate is known as the Van Deemter curve. Figure 3-2 is a calculated curve for hydrogen and a thin film 0.25mm capillary column. It graphically demonstrates the additive effect of B, C_m and C_s as described by equation 3-8. For thin film columns the effect of diffusion into the stationary phase is usually negligible. The value of D_s is assumed to be $3.3 \times 10^{-6} \text{cm}^2 \cdot \text{s}^{-1}$ at 85°C and the value of D_m is assumed to be $0.2 \text{cm}^2/\text{s}$ for hydrogen .

Figure 3-2: Calculated Van Deemter curve

$D_s = 3.3 \times 10^{-6} \text{cm}^2 \cdot \text{s}^{-1}$ (at 85°C), $d_f = 1 \times 10^{-4} \text{cm}$ dimethyl silicone
 $D_m = 0.2 \text{cm}^2/\text{s}$ (hydrogen), $k' = 10$, $r_c = 0.0125 \text{cm}$.

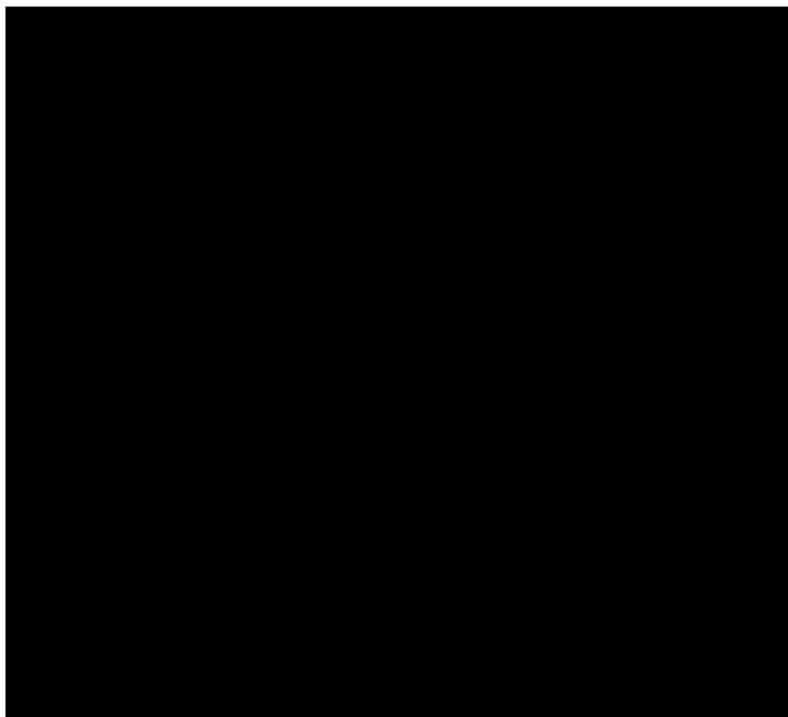

Differentiation of equation 3-8 with respect to mobile phase velocity, followed by setting the result to zero, leads to an optimum mobile phase velocity with a corresponding minimum in plate height⁶.

$$u_{opt} = \sqrt{\frac{B}{(C_m + C_s)}} \approx D_m/r_c \quad [\text{eq3-12}]$$

$$H_{min} = 2\sqrt{B(C_m + C_s)} \approx d_c \quad [\text{eq3-13}]$$

The highest column efficiency will be obtained at u_{opt} .

After separation between compounds is effected, minimization of analysis time of the separation problem is of interest.

3.3 Optimization of separation speed^{6,7}

Retention in chromatography is described by⁶:

$$t_r = \frac{L}{u}(1 + k') = N(1 + k')\frac{H}{u} \quad [\text{eq3-14}]$$

or, since the number of theoretical plates (N) attainable with a column is defined as the column length (L) divided by the theoretical plate height (H)

$$N = L/H \quad [\text{eq3-15}],$$

Retention can thus also be described as

$$t_r = N(1+k')H/u \quad [\text{eq3-16}]$$

where the flow rate is defined as

$$u = L/t_m \quad [\text{eq3-17}]$$

Retention times can be reduced at will, by reducing L or k' or increasing u. However, changing any of these parameters has a pronounced effect on the resolution between the compounds of interest. The possibilities for increasing speed of analysis for a given separation problem is limited by the relationship between retention time, column resolution and plate number.

When equation 3-16 is combined with the resolution equation (equation 3-1) an equation is obtained that relates retention time with resolution. If t_r is chosen as the last eluting compound then the well known equation 3-18 gives an indication of the total analysis time of a sample:

$$t_r = \frac{H}{u} \left[16 \left(\frac{\alpha}{\alpha - 1} \right)^2 \frac{(1 + k')^3}{k'^2} R_s^2 \right] \quad [\text{eq 3-18}]$$

While column length does not feature directly in equation 3-18, it is indirectly defined by the relationship between R and N in equation 3-1. An excess of resolution should be avoided as this leads to an increase in analysis time ($t_r \propto R_s^2$). Resolution tends to increase proportionally to the square root of the number of theoretical plates. Analysis time, however, is directly proportional to the column length. Thus, increasing column length to improve resolution is time-expensive.

3.3.1 The influence of capacity factor

Figure 3-3: The minimum retention time is obtained when $k'=2$.

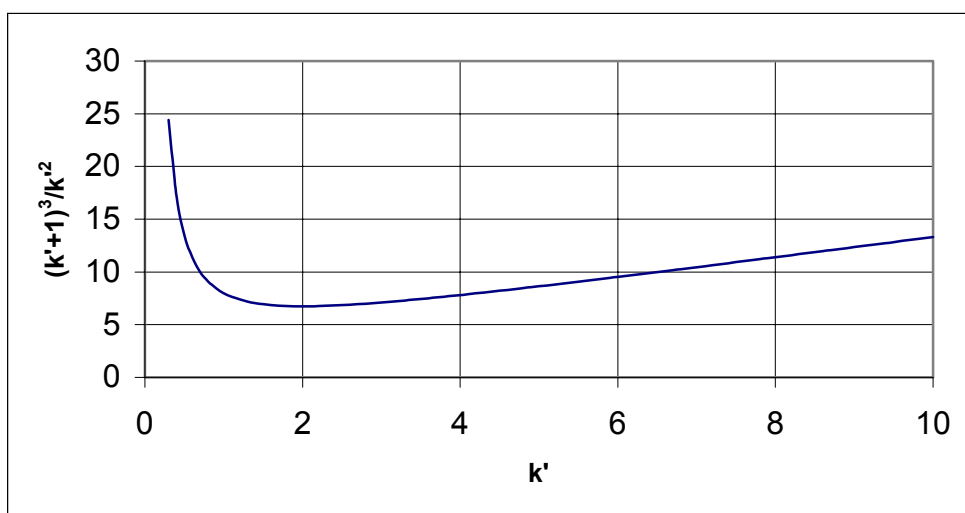

The influence on analysis time with variation in k' is graphically represented by Figure 3-3. It can be seen that the $(1+k')^3/k'^2$ term (equation 3-18) reaches a minimum at $k'=2$. However, it should be remembered from Figure 3-1 that the maximum resolution is

obtained for large values of k' where the $k'/(k'+1)$ term in the resolution equation (equation 3-1) approaches 1 (Figure 3-2). At $k'=2$ only $2/(2+1)$ i.e. 66% of the maximum resolution (at higher k' values) can be obtained. The column length could be increased to counteract the loss in resolution.

$$L = \frac{16R^2}{H} \times \left(\frac{\alpha}{\alpha - 1} \right)^2 \times \left(\frac{k'+1}{k'} \right)^2 \quad [\text{eq3-19}]$$

This equation is obtained by combining equation 3-1 and 3-15 and rearranging to solve for column length. Working at $k'=2$ an increase in column length of $(2+1)^2/2^2$ i.e. 9/4 or 2.25 is required to achieve the same resolution as would be obtained when working with higher retention factors.

3.3.2 The influence of selectivity

When a column is used with high selectivity between the compounds of interest, resolution is easier to obtain. This generally leads to a faster analysis as shorter columns or smaller k values can be used to obtain the required resolution. In gas chromatography high values of selectivity are generally only obtained for compounds that differ widely in boiling point. However, it can be calculated from equation 3-1, that for a conventional capillary chromatographic column that provides about $N=100\,000$ plates, a selectivity of only $\alpha = 1.02$ is required for $R_s=1$ with $k'=2$.

3.3.3 Influence of carrier gas flow rate and pressure drop

Replacing H in equation 3-18 by equation 3-7 the influence of column diameter (d_c) and carrier gas on t_r becomes apparent. H can be simplified to $B/u + C_m u$ when working with thin film open tubular columns and low pressure drop conditions ($|p_i - p_o| < 0.8 p_i$). At high flow rates, where the B term reaches a minimum, $H \approx C_m u$ and the ratio H/u stays constant. Under these conditions an increase in column length can be compensated for with a proportional increase in flow rate to maintain a constant R and retention time⁸. That means doubling the column length will not lead to an increased retention time, provided the flow rate is also doubled, ensuring constant N and therefore R^2 .

$$t_r = F(k') \left[16R_s^2 \left(\frac{\alpha}{\alpha - 1} \right)^2 \frac{(1 + k')^3}{k'^2} \right] \frac{r_c^2}{D_m} \quad [\text{eq3-20}]$$

When the pressure drop is high ($p_i - p_o > 0.8p_i$), f_1 in equation 3-7 approximately equals 9/8 and f_2 approaches 3/(2P). The retention time is then better described as⁶

$$t_r = F(k') \left[64R_s^3 \left(\frac{\alpha}{(\alpha - 1)^3} \right) \frac{(1 + k')^4}{k'^3} \sqrt{\frac{3\eta}{p_a}} \right] \frac{r_c}{\sqrt{D_m}} \quad [\text{eq3-21}]$$

where η is the dynamic viscosity

and p_o is the outlet pressure (normally atmospheric).

3.3.4 The influence of column radius

Following equation 3-20, the retention times increase at a rate equal to the square of the column radius ($t_r \propto r_c^2$). Thus when a column with 50 μm is used as opposed to a 250 μm column, a 25 times faster analysis can be effected. However, when a high pressure drop is present across the column, the retention time is proportional to the column radius ($t_r \propto r_c$, eq3-21) and the increase in speed is reduced to 5 times that of the wider bore.

3.3.5 The influence of diffusion coefficients

Using the kinetic model of gases⁹ the diffusion coefficient can be described as

$$D = \frac{1}{3} \lambda c \quad [\text{eq3-22}]$$

where λ is the mean free path without collision of gas molecules:

$$\lambda = \frac{kT}{\sqrt{2}\sigma p} \quad [\text{eq3-23}]$$

σ is the collision cross section of the molecule

and c is the average speed derived from the Maxwell distribution of speeds:

$$c = \sqrt{\frac{8RT}{\pi M}} \quad [\text{eq3-24}]$$

These equations imply that the diffusion coefficients of various gasses depend on their molecular mass and the collision cross section (σ).

Table 3-1: Collision cross sections/ nm²

Hydrogen	0.27
Carbon Dioxide	0.52

A comparison of the molecular mass and the collision cross-sections reveals that when hydrogen is used, diffusion coefficients 9 times larger than for carbon dioxide will be obtained.

In the low pressure drop case (eq 3-20) analysis times are 9 times faster when hydrogen is used as opposed to carbon dioxide. When a high pressure drop (eq3-21) exists the influence of diffusion coefficients ($t_r \propto 1/ (D_m)^{-2}$) are less and retention times are reduced by a third.

3.3.6 The relative contributions of column diameter v/s carrier gas identity

With the proposed two-dimensional SFCxGC_{fp} the first separation will be effected with high pressure CO₂. The possibility exists that it could also serve, after depressurization, as carrier gas for the GC analysis. When the influence of the carrier gas identity is compared to the decrease in analysis time through reduction of the column inner diameter, it can be concluded that for a narrow bore capillary (50 μ m) with CO₂, faster results will be obtained than using a wide bore capillary (250 μ m) with H₂. However the combined effect of using a narrow bore capillary together with H₂ will produce the best resolution in the shortest time.

In this way, resolution between a critical pair of analytes can be optimized with isothermal GC. When resolution between the critical pair is obtained it may happen that resolution between the other interesting compounds of interest is also obtained.

3.4 Temperature programmed analysis

While temperature programmed analysis does not improve the resolution that can be obtained from a specific set of chromatographic conditions, speed and the detection limits of such chromatograms are considerably increased. It has been shown that the dependence of the analysis time on the column inner diameter for a capillary column is the same in both isothermal and temperature programmed analysis¹⁰.

Diffusion coefficients are a function of temperature. However, it can be seen from equation 3-22 to 3-24, that the respective dependencies on temperature is the same for each of the gases. It can thus be assumed that hydrogen should also be the fastest gas for temperature programmed GC analysis. The difference in the change of viscosities for the different carrier gasses with temperature is small. This difference has been calculated to be roughly equal to 1°C over the entire temperature-programming range of several hundred degrees centigrade¹¹. Thus, it seems safe to assume that the influence on runtime of diffusion coefficients should also be the same for isothermal and temperature programmed chromatographic runs.

3.4.1 Heating rates

The reduction in analysis time in temperature programmed GC analysis depends on the heating rate - the higher the rate the shorter the analysis time. Unfortunately, an increase in heating rate causes a reduction in column peak capacity. The selection of the best heating rate requires a compromise between maintaining a minimum acceptable resolution for the sample while obtaining the shortest separation time.

The argument is the exact parallel to the role of temperature and capacity ratio (k') on the separation in the case of isothermal GC. Too high heating rates imply elution of compounds at too low k' values with consequent reduction in R (see figure 3-1). Too low heating rate implies final elution of compounds at too high k' values with resultant loss in separation speed (see Figure 3-3).

As opposed to the standard goal of achieving:

Good separation of a critical pair of solutes in the shortest time;

The optimization criteria of achieving:

An adequate separation of a required number of analytes in the shortest time,

is particularly useful for the general optimization of the proposed multidimensional application of fast GC. The required number of analytes can be expressed through the peak capacity (n). The analysis time of the sample (t_a) is taken as the elution time of the last eluting sample component. Blumberg¹² defined certain constraints relating to different pressure drop scenarios and obtained an optimum ramp rate (R_t) for each of the different conditions. These optima were expressed in unit temperature increase per void time (t_m). Void time is the time it takes for an unretained compound to elute from a chromatographic column.

$$r = R_t \times t_m \quad [\text{eq3-14}]$$

3.4.2 Normalized heating rates

The concept of normalized heating rate (r) substantially simplifies the optimization of the heating rate by reducing the range of possible values that represent the heating rate. Once an optimum heating rate has been experimentally found for a particular method, there is no need to make another set of experiments to find an optimum heating rate for each set of column dimensions, carrier gas, gas flow rate, outlet pressure or any other combination of translatable changes. Translatable variations allow one to change the heating rate without moving from the optimal normalized heating rate.

3.4.3 Default Optimum Heating Rate

Based on experimental data, Blumberg recommended that for columns with silicone stationary phases with $\beta \approx 250$ (the thin film case, $C_s \approx 0$) the optimum normalized heating rate is $10^\circ\text{C}/t_m$. Low pressure drop conditions require a factor 2 higher and an increase of 12% is suggested for every factor 2 increase in film thickness.

Table 3-2: Heating rate (°C/min) vs. column dimensions for H₂ at 10°C/tm¹³

Length /m	50	Diameter/ μm	250	320
1	1200	1200	620	490
5	110	140	110	90
10	40	53	51	44
25	10	14	17	16

As can be seen from Table 3-2 for shorter columns, the heating rate (R_T) is impossible with standard commercial gas chromatographs. For these high-speed separations, alternative methods of column heating are required. The major limitation on heating rates attainable with conventional stirred bath ovens is the huge thermal mass of the oven that needs to be heated together with the column. Modern methods provide heat directly to the small thermal mass of the capillary column. Very high heating rates up to 1200°C/min or more can be achieved. Some of the methods for obtaining these fast heating-rates will now be discussed.

3.5 Achieving fast heating rates

3.5.1 Resistive heating

Resistive heating has been applied successfully to direct heating of capillary columns. It is achieved by applying a voltage drop across a capillary that has been made electrically conductive. The increase in column temperature depends on the amount of power dissipated. The dissipated power (W) depends on the current (I) through and the voltage (V) across the column.

$$W = V I \quad [\text{eq 3-15}]$$

The current is dependent on the voltage drop and the resistance (R) of the column.

$$I = V / R \quad [\text{eq 3-16}]$$

The electrical resistance is dependent on the length, diameter wall thickness and composition of the electrically conductive column or conductive layer.

The amount of heat required for increasing the temperature of any substance by an increment ΔT is given by¹⁴

$$Q = mC\Delta T \qquad \text{[eq 3-17]}$$

Where Q is the heat (Joules or Watt-seconds), m is the mass of the material (gram), C is the heat capacity of the material ($J/g.C^\circ$) and ΔT is the change in temperature of the material. Eq 3-17 demonstrates that objects with large mass require more heat or power to reach the same temperature in a given time period than an object of smaller mass. The low thermal mass of a capillary column allows it to be rapidly heated while using much less power than is normally required with a GC oven. Even more important, low thermal mass allows for faster cooling and thus cycle times.

Methods of making columns electrically conductive

Resistive heating of flexible fused silica columns with metal cladding was first suggested by Lee in 1984¹⁵. The first practical demonstration of this technology for GC analysis was by Hail and Yost¹⁶ who used a short section of a commercial aluminum clad fused silica column. A programmable DC power supply was used to regulate the voltage across the column. The power supply output was regulated through a 0-5V signal derived from a digital to analog board.

Philips and Jain painted fused silica columns with a thin layer of electrically conductive paint and regulated the output from a programmable DC power supply in a similar way¹⁷. Mechanical instability due to differences between the thermal expansion coefficients of the fused silica and the coatings caused rupture of the conductive layer. This was further accelerated by local hot and cold spots caused by uneven coating. Chromatographic efficiency was degraded and the analytical column was damaged.

Mechanical stability was improved by Ehrmann et al¹⁸. They compared the use of a coaxial metal tube or collinear heater wire as an at-column heating element. Both approaches proved to be satisfactory, but the coaxial heater provided better retention time

reproducibility. The tubular design allowed the use of an auxiliary sheath gas to even out heat distribution along the column. While this gas had a statistically significant advantageous effect, the benefit was too small to justify the additional instrumental complexity. A pulse width modulator operating at 100Hz was used to control the temperature.

An instrument using a coaxial heater is commercially available. The Flash-GC¹⁹ embodies a conventional 0.25mm id column, either 6 or 12 meters long, placed inside a precision-engineered metal tube. The tube can be heated up to 1200°C/min but was sold in 2001 for approx. £20 000 pounds.

3.5.2 Microwave Heating

A recent commercial development uses a modified exterior polyimide coating that absorbs microwave radiation. The column is placed in a cell that can be installed into a traditional GC. With the microwave generator turned on, the column can be heated at rates up to 600°C/min. It takes about 60 seconds for the column to cool down to starting temperature, resulting in a typical cycle time of 180 seconds. Resolution and repeatability is claimed to rival conventional GC²⁰.

Induction or infrared heating could potentially be used for heating of the column.

3.5.3 Methods of sensing temperature

In the beginning, resistive heating was calibrated through an iterative process where the heating profile was changed until the desired normal paraffin separation was obtained¹⁷. This time consuming process was not very flexible and discouraged the changing of ramp rates. The actual column temperature and heating rates were also unknown.

Thermocouples could be considered impractical for this application due to their relatively large thermal mass in comparison to the capillary column wall onto which they are to be connected. Even if small sensors were placed on the column, local cold spots would be caused and this may lead to inaccurate temperature measurements, possibly producing peak tailing due to local cooling.

3.5.3.1 Resistance measurements

It was opted instead to use the resistance of the conductive capillary column as an indication of the average temperature¹⁷. The resistance of any metallic conductor is linearly related to its temperature over a large temperature range and is given by:

$$R_T = R_o(1 + \alpha T) \quad [\text{eq3-18}]$$

Where R_T is the resistance at T, R_o is the resistance at 0°C and α is the temperature coefficient of resistivity of the metal. The simplest way to measure the resistance is to calculate it from the current through, and the voltage drop across, the column:

$$R = V / I \quad [\text{eq3-19}]$$

Since the current through every point of a circuit is the same, the current through a high Wattage, low resistance, resistor in series with the column can be measured by measuring the voltage drop across this known and constant resistor. This was the approach followed by Hail and Yost¹⁶.

The resistance of the column was calibrated against known temperatures and used as a direct measure of temperature.

3.5.3.2 Resistance measurement with superimposed AC signal

Philips measured the resistance of the column by superimposing a supposedly constant current 10kHz square wave on top of the DC heating current. The square wave was sampled at 20kHz and the amplitude of this voltage measurement was proportional to the resistance and hence the temperature of the column¹⁷.

This circuit (Figure 4-2) was somewhat delicate and required empirical tuning to obtain good results. Very small signals of about 10 to 20mV had to be measured at high frequency. Electronic noise is definitely a problem in a laboratory environment with lots of electronic equipment. Despite the incorporated band pass filters, noise equal to 10°C can be discerned from the published graphic results.

3.5.3.3 Separate sensing wire

With the column-in-a-sleeve design by Ermann¹⁸ it was also possible to incorporate a separate sensor wire. A small constant sensing current was passed through the wire. The resultant voltage drop across the wire is proportional to the resistance of the wire (eq 3-19) and this resistance is proportional through equation 3-18 to the temperature.

3.5.3.4 Infrared temperature sensing

Infra red temperature sensors are excellent non-contact sensors and thus do not cause cold spots. They are available in models that offer much the same temperature range and linearity as type K thermocouples. However, even with close focusing optics the smallest measurement spot size of commercial models are 2.5mm². This is many times bigger than the surface of a capillary column. A couple of column windings could potentially be coiled tightly together but each coil would have to be electrically insulated from its neighbors and this will increase thermal mass and cool down times.

3.5.4 Temperature Control^{21,22}

In order to do useful gas chromatography it is necessary to accurately and reproducibly control the temperature. Isothermal temperatures should be well maintained and temperature ramps promptly and precisely followed. This implies that the temperature should be constantly monitored and control variables need to be continuously altered as the set-point changes or when the measured temperature is different from the set point. The process where a measurement is compared with a set point before corrective action is taken is called feedback control. The difference between the set point (SP) and the measured signal, also called the process variable, (PV) is the error(e)

$$e = SP - PV \quad [\text{eq 3-20}]$$

3.5.4.1 The proportional controller

A proportional controller attempts to apply power, W , to the heater in proportion to the size of the error, where P is known as the proportional gain of the controller:

$$W = P e \quad [\text{eq 3-21}]$$

As the gain is increased, the system responds faster to changes in set point and may eventually start to oscillate as the controller becomes unstable. When a small proportionality constant is chosen (Figure 3-2 no.2) the final oven temperature after a step function disturbance (Figure 3-2 no.1) lies below the set point because the product of the error and proportionality constant is too low to request adequate power from the heater. Increasing the gain alleviates this problem but at very high gain the process variable may overshoot and start to oscillate around the set point (Figure 3-2 no.4).

Figure 3-2: Proportional control

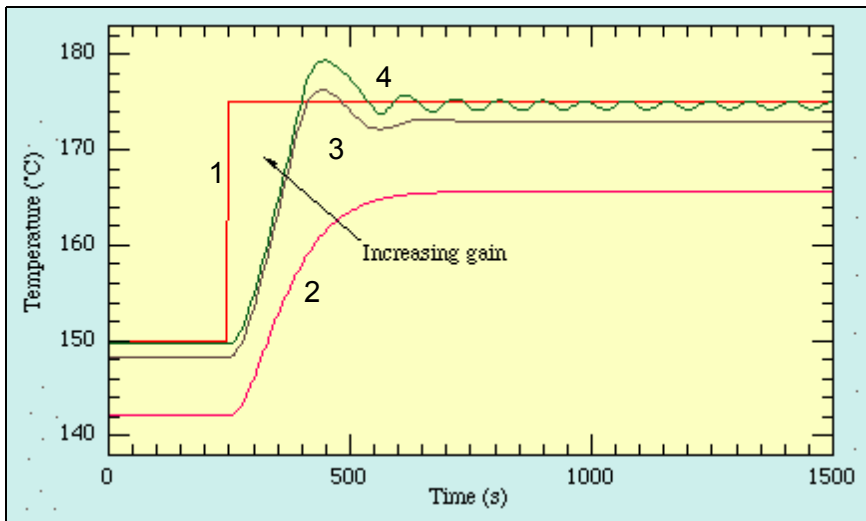

1. A step increase in temperature of set point.
- 2,3. Increasing the gain (P) causes faster response to set point changes
4. At very high gain, temperature (PV) oscillate around control value (SP).

3.5.4.2 Proportional+Derivative Control

Adding the time-derivative of the error signal to the control output can improve the stability and overshoot problems that arise when a proportional controller is used at high gain:

$$W = P \left(e + D \frac{d}{dt} e \right) \quad [\text{eq 3-22}]$$

This technique is known as PD control. The value of the damping constant, D , can be adjusted to achieve a critically damped response to changes in the set-point temperature, as shown in Figure 3-3. Too little damping results in overshoot and ringing (Figure 3-3 no.2), too much cause an unnecessarily slow response (Figure 3-3 no5).

Figure 3-3: PD control

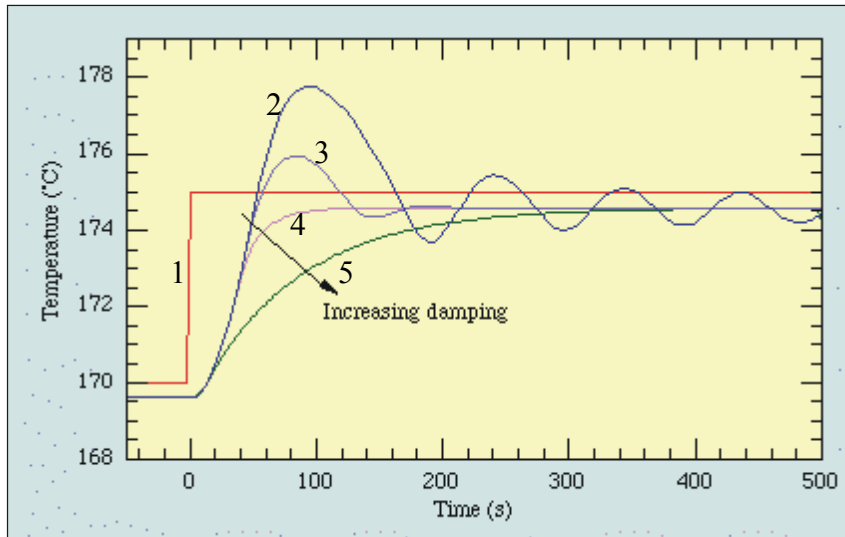

1. Set point with step increase in temperature
2. High gain causes 'ringing' of process variable
- 3-5. Increasing damping improves oscillations

3.5.4.3 Proportional+Integral+Derivative Control

Although PD control corrects the overshoot and ringing problems associated with proportional control, it does not cure the offset problem encountered when a small gain is used. Fortunately, it is possible to eliminate this steady-state error while using relatively low gain by adding an integral term to the control function, which becomes:

$$W = P \times \left(e + D \frac{d}{dt} e + I \int e dt \right) \quad [\text{eq 3-23}]$$

Here, I , the integral gain parameter is sometimes known as the controller reset level. This form of function is known as proportional-integral-differential, or PID, control. The

effect of the integral term is to change the heater power until the time-averaged value of the temperature error is zero. The method works quite well but complicates the mathematical analysis slightly because the system is now third-order.

Figure 3-4: PID Control

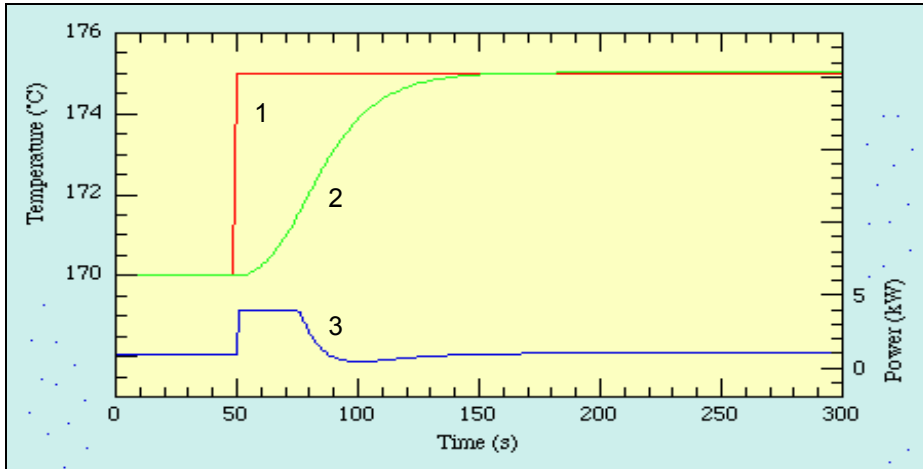

1. Step increase in set point.
2. Process variable (temperature) follows set point.
3. Controller output.

Figure 3-4 shows that, as expected, adding the integral term has eliminated the steady-state error.

3.5.4.4 Proportional+Integral Control

Sometimes, particularly when the sensor measuring the oven temperature is susceptible to noise or other electrical interference, derivative action can cause the heater power to fluctuate wildly. In these circumstances it is better to use a PI controller or set the derivative action of a PID controller to zero. When a ramp as opposed to a step function is used to set the temperature, derivative action is often not required.

3.5.5 The Control variable

For resistive heating there are two control possibilities:

1. A continuous current can be increased or decreased depending on the size of the error signal
2. or a fixed current output can be turned on and off for various lengths of time in response to the error signal. The latter case is called pulse width modulation (PWM).

3.6 Chapter conclusion

Temperature programming of the chromatographic column is required for the separation of the wide boiling point range of samples with the 2nd dimension of the SFCxGC_{ftp}. Fast heating rates are required, because of the limited time available for the 2nd dimension analysis. Resistive heating is a well-established technique for fast heating of capillaries. While commercial resistive heating instrumentation is available, when attempting to duplicate such a system, the various methods of temperature sensing should be compared.

Chapter 3

- ¹ R. Annino, HRC 19 (1996) p285
- ² A. Peters, R. Sacks, J. Chrom. Sci 30 (1992) p187
- ³ A. A. Zhukhovitskii, et al, Doklady Akademii Nauk S.S.S.R. 77 (1951) p435
- ⁴ L. M. Blumberg, J. B. Philips, J. Chrom. Sci 35 (1997) p451
- ⁵ L. M. Blumberg, Chromatographia 39 (1994) p719
- ⁶ A. van Es, High speed narrow bore capillary chromatography, 1992, Huthig buch verlag GmbH, Chapter 1
- ⁷ C. F. Poole, S. K. Poole, Chromatography today, New York : Elsevier (1991) Chapter 6
- ⁸ J. B. Lourens, Gas chromatographic trace analysis of sulphur compounds: industrial applications, PhD Thesis (1997) University of Pretoria, p40
- ⁹ P. W. Atkins. Physical Chemistry. Oxford: Oxford University Press 4th ed. (1990) Chapter 24 p722
- ¹⁰ C. P. M. Schutjes, E. A. Vermeer, J. A. Rijks, C. A. Cramers, J. Chromatogr. 253 (1982) p1
- ¹¹ L. M. Blumberg, M. S. Klee, Anal. Chem, 70 (1998) p3828
- ¹² L. M. Blumberg, M. S. Klee, J. Microcol. Sep 12 (2000) p508
- ¹³ L. M. Blumberg M. S. Klee, lecture presented Riva Conference (2000)
- ¹⁴ A. F. Mills, Basic heat and mass transfer, Irman Inc (1995) Chapter 1
- ¹⁵ M. L. Lee, F. J. Yang, K. D. Bartle, Open tubular gas chromatography: Theory and Practice, John Wiley and Sons NY (1984) p110.
- ¹⁶ M. E. Hail, R. A. Yost, Anal. Chem. 61 (1989) p2410
- ¹⁷ V. Jain, J. B. Philips, J. Chrom. Sci. 33 (1995) p55
- ¹⁸ E. U. Ermann, H. P. Dharmasena, K. Carney, E. B. Overton, J. Chrom. Sci. 34 (1996) p533
- ¹⁹ Flash-GC™ Brochure, Thermedics Detection Inc, Chelmsford, MA, USA (1998).
- ²⁰ Int. Lab. 31(4a) p18.
- ²¹ National Instruments, PID control toolkit for G Reference Manual, (1998)
- ²² <http://newton.ex.ac.uk/teaching/CDHW/Feedback>

Chapter 4

Fast Gas Chromatography: Design, construction and evaluation of a fast gas chromatograph

4.1 Introduction

In this chapter the design and construction of a gas chromatograph capable of very fast temperature programming rates is described. Computer controlled, fast heating rates were obtained through direct resistive heating of a stainless steel capillary column. The current through a conductive metal capillary was controlled through feedback to follow a set temperature ramp with fidelity. A user-friendly PC based interface was designed.

Various temperature measurement circuits were built and compared for ease of implementation.

The retention time reproducibility of the constructed fast resistively heated GC is compared with that of other resistively heated gas chromatographs, as reported in the literature.

The linear gas flow and temperature-programming rates were optimized following the recommendations made by Blumberg¹. This optimized fast resistively heated GC was used for construction of the comprehensive SFCxGC_{ftp}.

4.2 Instrumentation

4.2.1 Column and electrical connections

A Varian 3300 GC (Varian Inc., MA, USA) was used to host the fast resistive GC. Mainly the gas plumbing and detectors of the host GC were needed, however the oven

¹ L.M.Blumberg, M.S.Klee, J.Microcol.Sep. 12 (2000) p508

was useful for maintaining a stable, temperature controlled environment. The cryogenic facility was convenient for cooling down the column after analysis. The temperature control printed circuit board on the Varian was modified to allow remote and independent command over the oven heater, oven fan and cryogenic cooling facility by the controlling computer. This was done by respectively forcing pin 1 on U22, U23 and U26 to TTL low. R47 was also forced to TTL low to deactivate the 'Fault 21'-message indicative of a problem with the heating circuitry².

Figure 4-1: Schematic diagram of injector connections.

Detector connections are similar.

- | | |
|-------------------------------|---|
| 1.Connection to power supply, | 2.Septum, |
| 3. Needle valve | 4.Computer actuated solenoid valve, |
| 5.Pressure control | 6.Glass insert, |
| 7.Frit , | 8.Insulation(ceramic disk and vespel ferrule) |
| 9.Graphite ferrule. | |

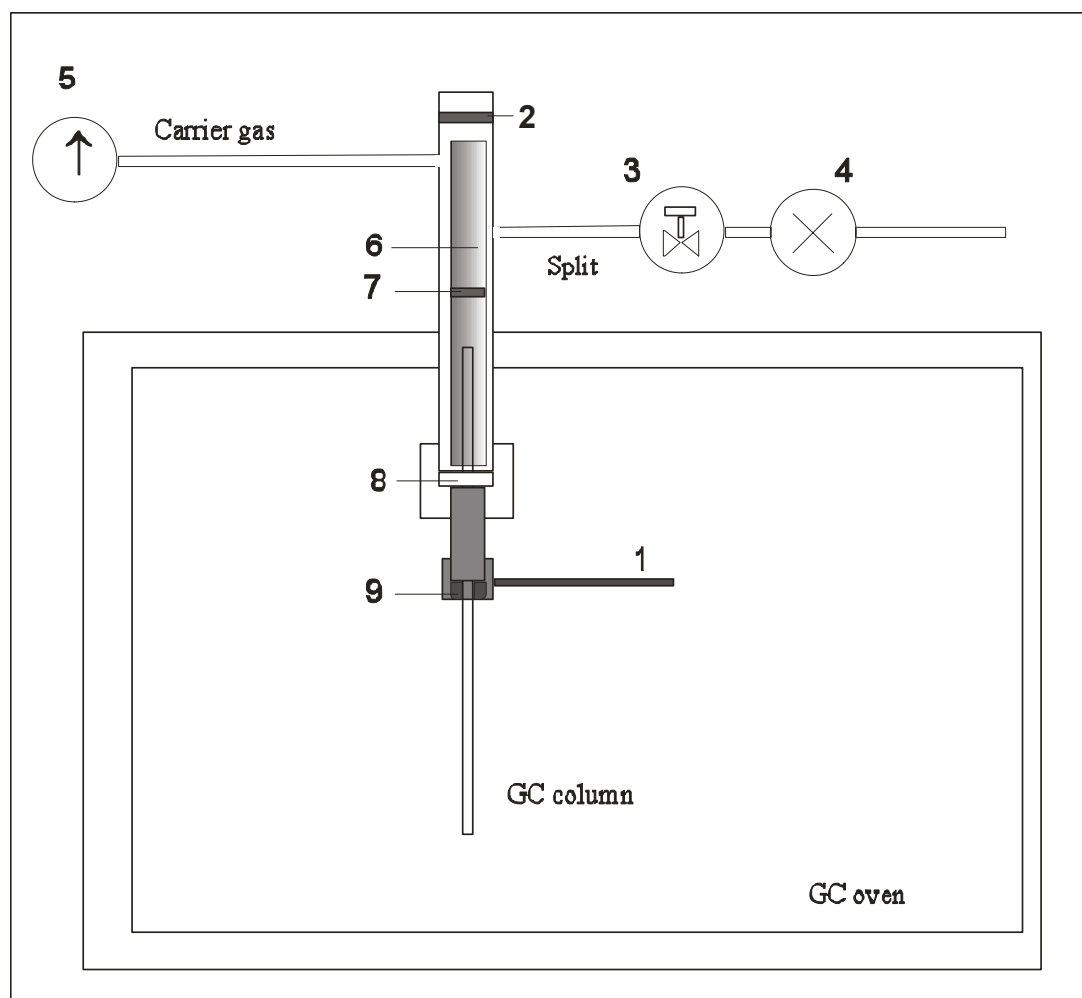

² R.Strydom, Personal communication, SMM Instruments, SMM House, Kyalami Business Park, Midrand, 1685, South Africa

A one-meter section of 0.25mm i.d. SE-30 stainless steel column (Quadrex Corp. SS Ultra alloy) was tightly coiled. After release, the coil diameter relaxed to 1.5cm. The column was connected to the split/splitless injector and FID detector on the host GC. A 30V-power supply was connected to the heated column connectors on the injector and detector legs. Electrical connections were made by silver soldering thick copper leads to the column connection screws. Graphite ferrules ensured good electrical contact between the connectors and the metal column. The detector and injector legs were electrically insulated from the body of the GC by using pure Vespel ferrules between the injector and detector legs and their bodies. At the detector side, the intruding section of the leg was painted with poly-imide resin to prevent electrical contact higher-up inside the detector body. On the injector side a ceramic washer was placed between the spring, that keeps the injector liner in place, and the injector column connector, that protrudes into the oven.

All electrical connections between the electronics-box, column and PC were through a SCB-68 connector block accessory (National Instruments, Texas,USA).

4.2.2 Current Control

The current delivered by a DC power supply (King Electronics Company, (Pty) Ltd) was controlled by changing the value of a 0-5V DC-out signal derived from a multipurpose data acquisition (DAQ) board (PCI-6024E, National Instruments).

The control output was amplified with an operational amplifier (LM 741). The output from the operation amplifier was connected to the base of a power transistor (Details given below). By changing the bias to the base of the power transistor, the current output of the supply through the column was controlled. While the power supply can deliver 6A, typically less than 3A was required to heat the 1 meter resistive column at all practical rates.

Two different current control circuits were used depending on the method of temperature sensing:

For the Resistive Measurement Circuit (Figure 4-4) the column was connected to the collector of a PNP power transistor. The base of the power transistor was connected to the collector of a smaller NPN transistor. In this way enough current could be supplied to drive the larger power transistor.

For the AC measuring circuits the power transistors (3 Darlington pairs used in parallel) were connected between the column and ground potential as opposed to between the power supply and the column. A Darlington pair is similar to the situation described above where a smaller transistor drives a bigger one. In this case it was convenient to have both transistors in the same package. Three transistors were used in series to prevent self-heating effects. This second power circuit was used for thermocouple measurements but here either circuit could be used.

4.2.3 Temperature sensing

Five different methods of temperature sensing were attempted.

4.2.3.1 Philips circuit

A circuit based on the one described by Philips³ was constructed. A 10kHz square wave pulse train was created from a counter chip on the DAQ board. LabVIEW Program 1.a <*simple control.vi*> was used. This was connected through an optically coupled switch (NTE3085), operated in conjunction with an 8V isolated power supply to protect the computer from the high voltage and current present on the column during programming. The 10kHz signal was applied across the column and coupled in a capacitive manner to a voltage following amplifier. The output from the amplifier was connected to an analog input on the DAQ where it was sampled at 20kHz. Sampling was synchronized to wave generation by using LabVIEW's built-in *triggered acquisition.vi*. This ensured that the samples were taken from the center of each pulse. Sample averaging was used to compensate for noise and thus improve accuracy of measurements.

The height of each digital conversion is related linearly to the electrical resistance of the column and thus to the temperature through Equation 3-18. Calibration of the system was achieved through measuring the height of the pulse train at several known temperatures, obtained from the host GC oven. The LabVIEW *PID.vi*, obtained from the PID control toolkit, was incorporated into the operating program to facilitate temperature feedback control.

³ V.Jain, J.B.Philips, J.Chrom Sci. 33 (1995) p55

Figure 4-2: The Philips circuit

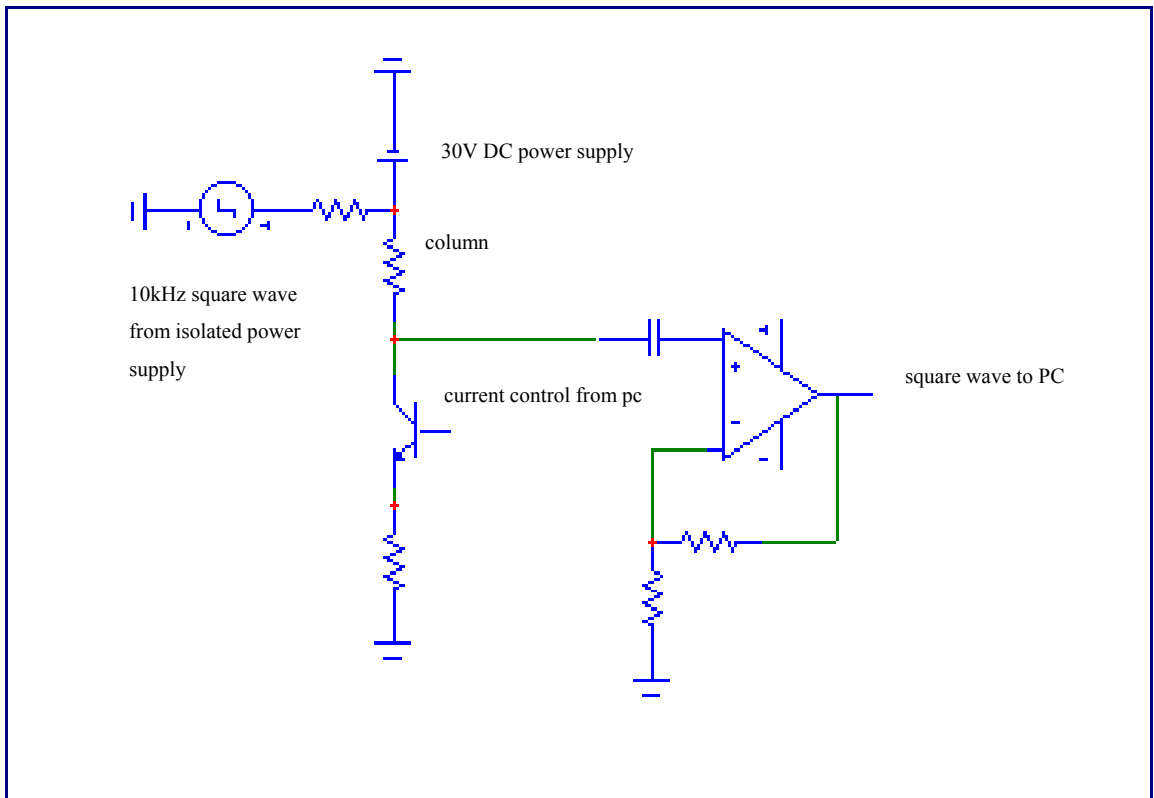
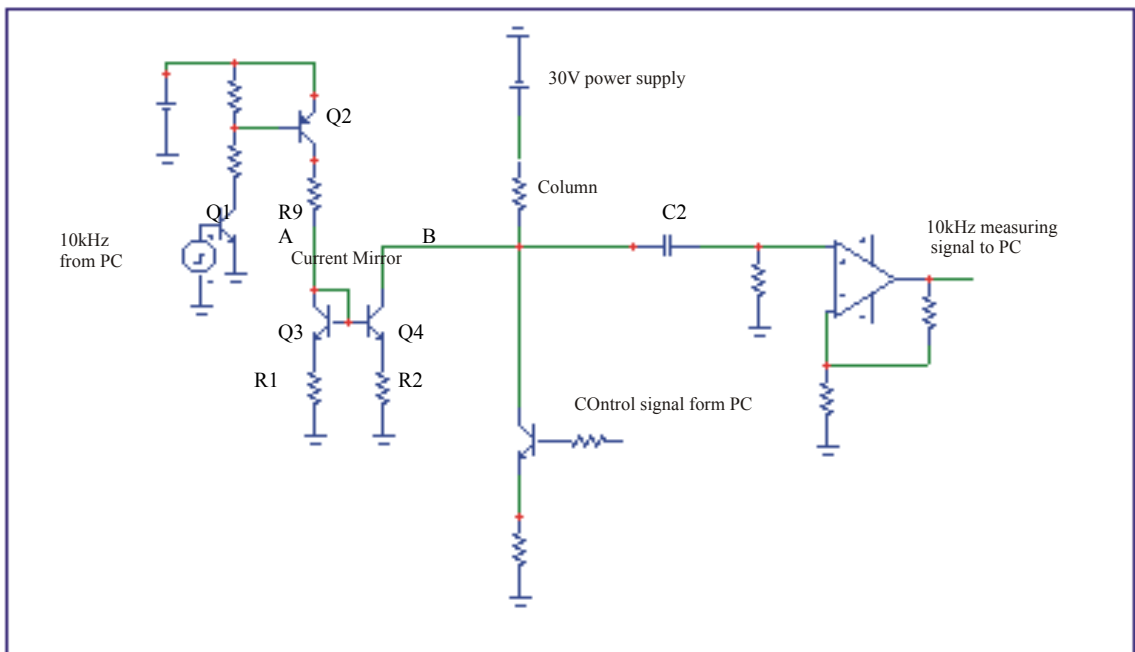

Figure 4-3: The current mirror circuit



4.2.3.2 Current mirror circuit

The measuring signal can be coupled through a *current mirror* to the column. The current mirror is a device that ensures that the currents through both collectors of the two transistors are equal. This implies that the current through B (Figure 4-3) and thus through the column, is the same as the current that flows through A. Resistor R1 and R2 are included to improve current stability, which may otherwise vary by 25% due to the Early effect⁴. The current through A is determined by the resistance and the voltage across R9. This was set to 50mA by using an 8V isolated power supply and a 150 Ω resistor. However the measured current that flowed into the collector of Q3 was only 30mA.

In this way the 5mA square wave from the output of the counter chip was increased to the 30mA by transistor Q2 and Q1 through resistor R9.

The current through Q4 was supplied from the power source that effected heating. This produced a square wave on the column that followed the wave supplied by the counter chip on the computer. The same 10kHz AC pulse train, as used in the previous circuit, was used.

The AC measuring signal was connected to an analog input channel on the DAQ through a high-pass filter. Differential signal connections were used. The same LabVIEW programs (1.a) as used for the Philips circuit were used.

4.2.3.3 The Resistance Measurement Circuit

With this circuit the resistance of the column is obtained through measurement of the Voltage drop and the current through the column. This is used as an indication of column temperature. The Voltage drop across the column was measured by reading the potential difference over the column. The voltage difference between points A and B in Figure 4-4 is an indication of the voltage drop due to the resistance of the column. A second voltage drop was measured across a fixed resistor. This reading is proportional to the current through the column as long as the value of this resistor is known and fixed. Five 4.7 Ω , 25W resistors were connected in parallel to prevent self-

⁴ P.Horowitz, W.Hill, The art of electronics, 2nd ed. (1995) Cambridge University Press p88

heating and keep the temperature of the resistors low and constant. This produced a resistance of 1Ω with a 125W power rating. The resistors were also mounted on a heat sink. A small current of 100 mA was required when the column was not heated to allow readings to be taken. Signal averaging of input voltages was used to compensate for noise.

(See LabVIEW Programs 2.a and 2.b)

Figure 4-4: The resistive circuit

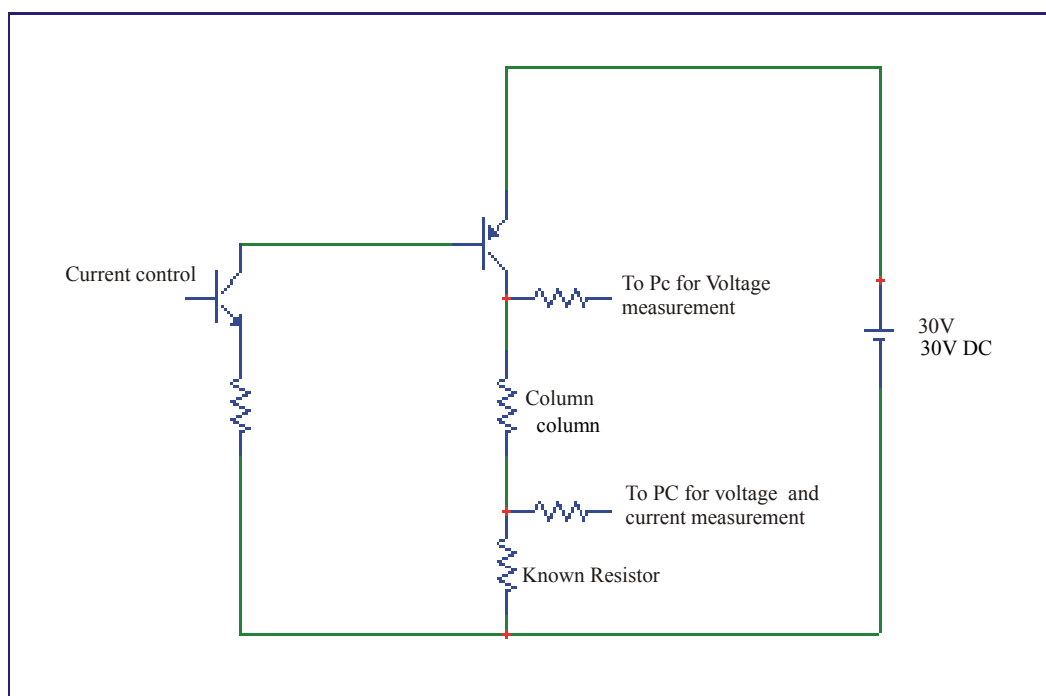

4.2.3.4 Thermocouple Measurements

A very small thermocouple was constructed from type K thermocouple wire ($T1 = \text{Ni}90/\text{Cr}10$; $T2 = \text{Ni}95/(\text{Al}+\text{Mn}+\text{Si})5$). The wires had diameters of 25 micrometer and were insulated with a poly-imide coating (Goodfellow, Cambridge GB). The poly-imide coating was removed from the ends of the two wires with a butane cigarette lighter by holding the them about 3 cm above the flame.

Two methods of making the very small thermocouples were tested:

- The stripped ends of the two wires were twisted. Silver solder was dipped in flux and melted in a butane/air flame. The twisted pair of thermocouple wires

was then pulled through the ball of molten solder. Best results were obtained when the twisted ends were pulled through first with the legs following. This produced a big blob at the outer end that tapered off towards the legs. This could then be trimmed with a scalpel to give a small thermocouple.

While thermocouples could be produced in this way, the procedure had to be repeated many times to yield a satisfactory thermocouple. Much time and expensive thermocouple wire were wasted in the process.

- In contrast, making the thermocouple by spot welding was relatively easy and produced a much smaller thermocouple. A special procedure had to be followed to ensure that the current did flow through the thin thermocouple wires and not directly between the two spot welder-contacts. The following method was used:

A copper base plate was connected to the ground potential of the welder. On the high potential side a sharply pointed probe was connected. The polyimide coating was removed from the ends of the wires. The stripped ends of the thermocouple wires were crossed on an insulating material and were extended onto the grounded base-plate where it was kept in place with sticky tape. Contact was made to the wires just before the cross while ensuring that both wires were in contact with the probe. See Figure 4-5.

Figure 4-5: Photograph showing how thermocouple wires are positioned for making a thermocouple by spot welding.



In this way it was ensured that the current flowed through the thermocouple wires to the base plate. When energy was discharged, the two wires melted together at the cross to form a thermocouple. With both methods, the resistance of the thermocouple wires were tested with a multimeter to ensure that the wires are joined properly.

The thermocouple was glued to the column using poly-imide resin (Figure 4-6). A little polyimide resin was painted onto the column. This tended to pull into a droplet on the column. A small heating current was applied to the column to facilitate evaporation of the toluene solvent. After the resin became sticky the thermocouple was submerged into the drop and held in place by hand for a minute or two until set. A larger current was then applied until the temperature reading, as measured on the column, remained constant indicating that all the toluene had evaporated. No thermocouple calibration was required and cold junction compensation was automatically programmatically performed by the LabVIEW drivers (NIDaq version 5.7).

Thermocouples were differentially connected through a 40Hz low band pass RC filter to an analog input on the SCB-68 accessory. Two 100K Ω bias resistors were connected between each of the wires and ground potential. LabVIEW program 3.a and 3.b were used for control of the resistively heated gas chromatograph.

Figure 4-6: The thermocouple is glued to the coiled column

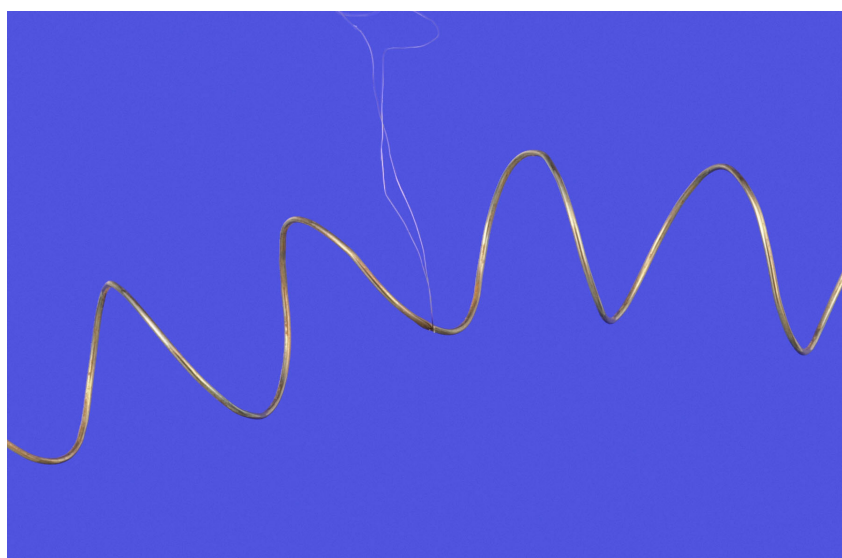

4.2.3.5 Fixed current ramp

The thermocouple readings, taken repeatedly at many temperatures, were used to define a current ramp. The output values were recorded and Microsoft Excel was used to obtain the average function. The coefficients had to be adjusted through an iterative process until the required ramp was followed with acceptable fidelity. This was checked by thermocouple readings, measured concurrently with column heating. The ramp was applied to the column without feedback control.

4.2.4 Data collection

The A/D converter on the Varian FID board was too slow to be used for fast GC data collection. Instead a fast variable response rate converter was salvaged from an old magnetic sector mass spectrometer (VG model FA3). The output from the FID was connected directly to the preamplifier of the FA3. The signal was collected by Chromperfect Software (Justice Innovations) after amplification.

4.2.5 Reproducibility

The reproducibility of the fixed current ramp and the thermocouple were investigated and compared with the published reproducibility results of other resistive GC's. Unfortunately, the others circuits could not be persuaded to yield temperature programs and were not tested for reproducibility. 0.2 μ L of a sample containing n-alkanes between decane and tetracosane in CS₂ was injected by hand 10 times.

4.2.6 Optimization of rate

Following the work by Blumberg, the adequate separation of a required number of analytes in the shortest time was found by increasing the flow rate and temperature programming rate, while keeping the normalized ramp rate constant. A sample containing the n-alkanes between C₁₀ to C₂₄ was made up in CS₂ and injected at each set of ramp and flow rates. The peak capacity obtained was calculated and plotted against analysis time. Each set was repeated three times.

4.3 Results and discussion

4.3.1 General comments

Commercial stainless steel columns did not produce the problems encountered due to differences in expansion coefficients experienced with aluminum clad or painted columns, more over they appeared to be stable and unreactive. The manufacturers claim that the walls are very homogenous in diameter and thickness⁵. This ensured constant heating across the length of the capillary. With a resistance of $\approx 11\Omega/\text{m}$ there was no need for coating the capillary with an additional conductive layer. The resistivity of UltraAlloy was found to be $162\mu\Omega/\text{m}$. The larger the temperature coefficient (tempco), the larger the increase in output for a given increase in temperature. Higher tempcos mean that temperature set points can be followed with more accuracy. While less sensitive than aluminum and Nickel, the tempco of UltraAlloy compares favorably with other metals of high resistivity. This makes Ultra Alloy a good material for the measurement of temperature as a function of resistance.

Table 4-2: Resistance data of common metals⁶

Material	Resistivity ($\mu\Omega.\text{cm}$)	Temperature coefficient of resistance ($\Omega/\Omega/^\circ\text{C}$)
Nichrome	108	0.00036
304 SS	73	0.00094
321 SS	71	0.00123
Nickel	8	0.006
Aluminium	2.67	0.00446
UltraAlloy*	162	0.00099

*Experimentally determined

The column can be tightly coiled. A diameter less than 1 cm can be tolerated without loss of deactivation⁵. Upon release of tension, the coil maintains its structure and no additional support was required to keep it in shape or to insulate individual turns. The

⁵ http://www.frontier-lab.com/products/column/Ultra_ALLOY_Columns.html

⁶ R.S.Scharlach, Electronic Design, 22, (1979) p106

advantage to this is a reduced thermal mass, which translates into faster heating and cooling rates.

While using the commercial column without additional heating-sleeves provided flexibility in column length, in practice the column length was limited to 1 meter by the size of the oven. It was impossible to use longer columns without the column touching the sides of the oven, causing a short-circuit to ground potential. A longer column would increase plate numbers. This would be beneficial for the separation of the complex fractions transferred from the SFC.

One disadvantage of heating the SS-column directly is that currently they are only available in a few inner diameters. The narrowest column available has an inner diameter of 0.25 mm. A narrower bore would be advantageous for increasing plate number production per unit time for fast chromatography.

4.3.2 Additional heating of injector and detector legs

Figure 4-6: Temperature of injector and detector legs during a temperature ramp.

Detector and injector temperatures were set to 280°C. Resistively heated column at 250°C. Host GC oven at 40°C.

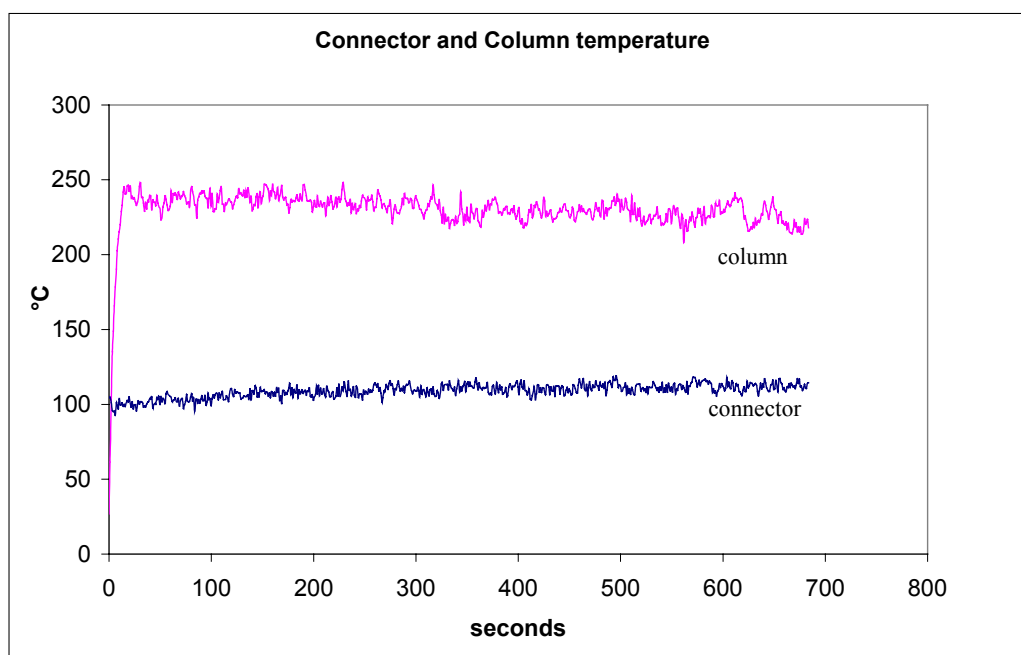

The column was installed into the column connectors (legs) of the injector and detector on the host GC. These were heated up to 280°C to ensure that the electrical connections did not cause cold spots at the point of connection. The responses of the different circuits were then calibrated by increasing the oven temperature. However, it was soon realized that the results obtained with the resistively heated GC did not match those made under similar conditions where the temperature was controlled by the host GC oven. With the resistively heated GC, the peaks produced by less volatile compounds would take longer to elute than expected and severe tailing was observed. After investigation it was found that the mounted block heaters did not heat the injector and detector legs adequately. While the injector and detector bodies were at 280°C, temperatures below 100°C were measured on the legs protruding into the GC oven (Figure 4-6). With conventional use of the Varian GC it is never a problem, as the protruding column connectors are heated up with the oven temperature as it is programmed. To circumvent this problem, additional heaters were installed around the column connectors to ensure proper heating. This was achieved by connecting a VariAC to an insulated heating tape and winding the heating tape around the injector and detector column connectors. The temperature was measured with a thermocouple and the voltage was manually regulated to maintain the temperature at or above the maximum of the column ramp.

After this, the shape and elution pattern of the chromatogram obtained with the resistively heated GC more closely resembled the chromatograms obtained with the conventional temperature programmed GC.

The four different temperature-sensing circuits, discussed in the previous section, were built for comparison. However, only the thermocouple, thus far, produced usable results. The various circuits and their problems are discussed below.

4.3.3 The Philips circuit

The use of a square wave for measurement has two advantages:

1. The measurement-current flows only half the time and probability of noticeable heating of the column by the sensing current is reduced.
2. The AC measurement signal can be extracted from the DC heating current and from environmental electronic noise.

The heating current control can only be seen as a perfect current source if the power transistor remains at a constant temperature. Three TIP-142's were used in parallel and mounted to a heat sink with fan to ensure isothermal operation.

Figure 4-7: Calibration curve obtained for Philips circuit

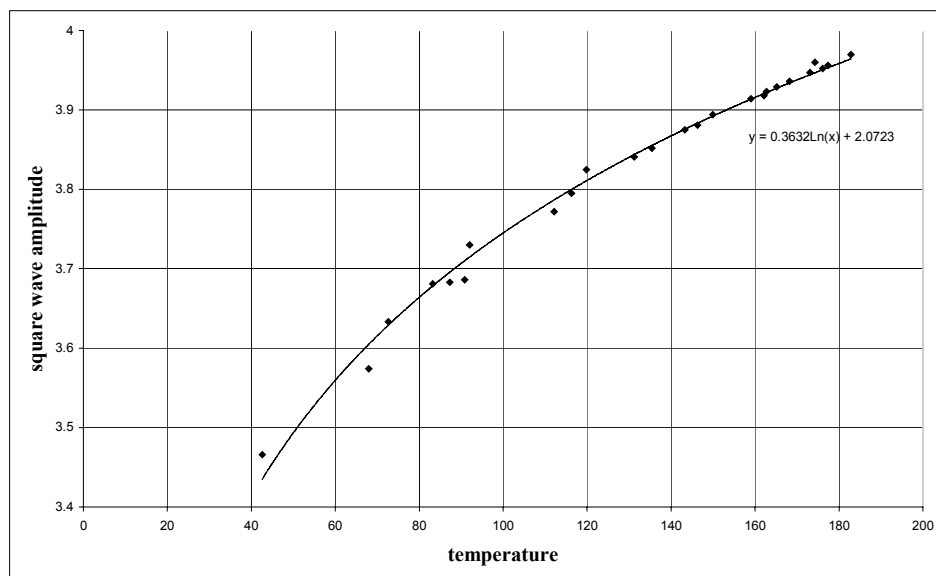

By placing the column in the oven and obtaining amplitude readings at known temperatures, maintained by the host GC, an exponential temperature versus amplitude calibration curve could be obtained. The measured amplitude of the square wave increased with ≈ 1.5 volts across the 300°C -temperature range. This correlates to a 5mV increase per $^{\circ}\text{C}$. With the 12bit AD converter used, a resolution of 0.01°C could potentially be obtained.

However, when a heating current was applied erroneous readings were obtained. Readings would decrease when the heating current was switched on to readings much lower even than any of those measured for the calibration curve.

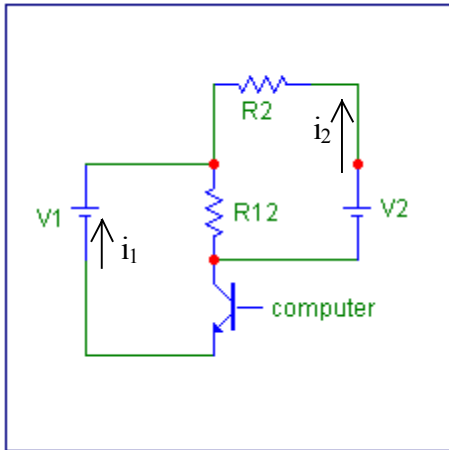
Figure 4-8: Simplified Philips circuit

The circuit is based on the assumption that the measuring current i_2 and the heating current i_1 are independent. Applying Kirtchoff's law, which states that the sum of currents into a point in a circuit equals the sum off currents out⁷, revealed a fundamental flaw in this approach:

$$i_1 = const$$

$$v_2 = i_2 R_2 + i_2 R_{12} + i_1 R_{12}$$

$$v_2 - i_1 R_{12} = i_2 (R_2 + R_{12})$$

$$i_2 = \frac{v_2 - i_1 R_{12}}{R_2 + R_{12}}$$

$$v_2 = 8V, R_2 = 300\Omega, R_{12} = 4\Omega$$

Table 4-3: The two currents are not independent.

i_1	i_2
0	0.026
0.4	0.021
0.8	0.016
1.2	0.011
1.6	0.005
2.0	0.000

⁷ P.Horowitz, W.Hill, The art of electronics, 2ndEd., (1995) p3,33

The value of R_{12} is assumed to stay constant in the calculations. However it increases as the current increases due to the higher temperature of the resistor. This increase is dependent on the resistivity coefficient of the column material. For the metal used here the resistance of the 1 meter column may increase with about 1Ω between $i_1 = 0$ and $i_1 = 2$ Amp as the temperature of the column (R_{12}) increases from ambient to 350°C . Thus, the dependence of i_2 on i_1 may be slightly less than suggested by the preceding calculations.

This circuit possibly worked for the published results because very short column segments were used for temperature measurement. According to Phillips⁸, resistance of the column segment (R_{12}) that is measured must be small relative to the resistor R_2 . In our case $R_{12} \approx 12\Omega$ and $R_2 = 300\Omega$. However, when shorter column segments are used, temperature-sensing resolution is sacrificed because the measured difference in resistance with a change in temperature is reduced.

Since the two currents are not independent, it is impossible to heat the column and measure the temperature simultaneously. This circuit may still be practical when pulse-width modulation is used for column heating. The measuring signal will then be applied during the off phases in between the heating pulses. Alternatively the circuit should work well when a separate sensing wire is used.

Additional problems encountered with this circuit were the 30mA required by the optical switch to operate properly while the counter chip on the board delivers only 5mA. The pulse train from the counter chip on the multifunction input/output board in the computer was however reasonably well maintained and only lost some of its sharpness on the rising edge of the pulse. This can in part also be attributed to the slow rise time of some of the capacitors and band pass filters required to clean up the noisy input signals. However, this did not interfere with measurements, which were always taken from the center of the high and low regions of each square wave.

⁸ J.B.Phillips, Private communication.

4.3.4 The current mirror circuit

Unfortunately it was not possible to get this circuit to function properly. The square wave was extracted from the DC signal through capacitor C2 (Figure 4-3), which formed part of a high band pass filter to decrease noise. The band pass filter, unfortunately, loads the signal and this decreases sensitivity. The *synchronized data acquisition* subprogram (LabVIEW program 4.3.4) reported a time-out error signal. This was probably due to the input signal being too small to trigger acquisition on the analogue to digital board. In an attempt to amend this problem, an additional operational amplifier was connected prior to the analog input into the computer. However, this distorted the square wave severely and measurement was impossible. Research attention at this point, out of desperation, was moved onto other temperature measurement possibilities. Since these were probably not fundamental problems with the circuit, an electronic engineer may in future solve the technicalities and allow this circuit to be used for resistive temperature measurement.

4.3.5 Resistance of heating element by Ohms' law

This is a far simpler approach to temperature measurement than the previous attempts. The resistance of the column is calculated from current and voltage drop measurements. The temperature is then calibrated against resistance.

The value of the current sensing resistor has a great influence on the sensitivity of the measurement. The larger the resistor, the larger the voltage measurement for an increase in current. However, larger resistors are more prone to self-heating. When a resistor heats up, its resistance changes and this will lead to erroneous readings as the resistance of the warm resistor is no longer known. The resistance of $\approx 1\Omega$ obtained from using five $4,7\Omega$ resistors in parallel is quite large for this type of application. However, internal heating was limited by using bulky resistors with a high wattage rating (25W each). The use of five resistors in parallel has the effect of dividing the current through each resistor by five, thus further reducing self-heating. The resistors were also mounted on a heat sink to aid effective dissipation of any produced heat.

Even when the column was not heated, a constant low current was still required for measurement purposes. It was found that at least 0.1A was needed for the circuit to operate satisfactorily. It is unlikely that 0.1A should cause significant heating of the column. When the temperature was increased by the host GC, a logarithmic relationship between resistance and temperature was obtained (Figure 4-8).

Figure 4-8: Resistance calibrated against known temperatures.

Maintained by the Host GC for the Resistance circuit. A measuring current of 0.1Amps was used.

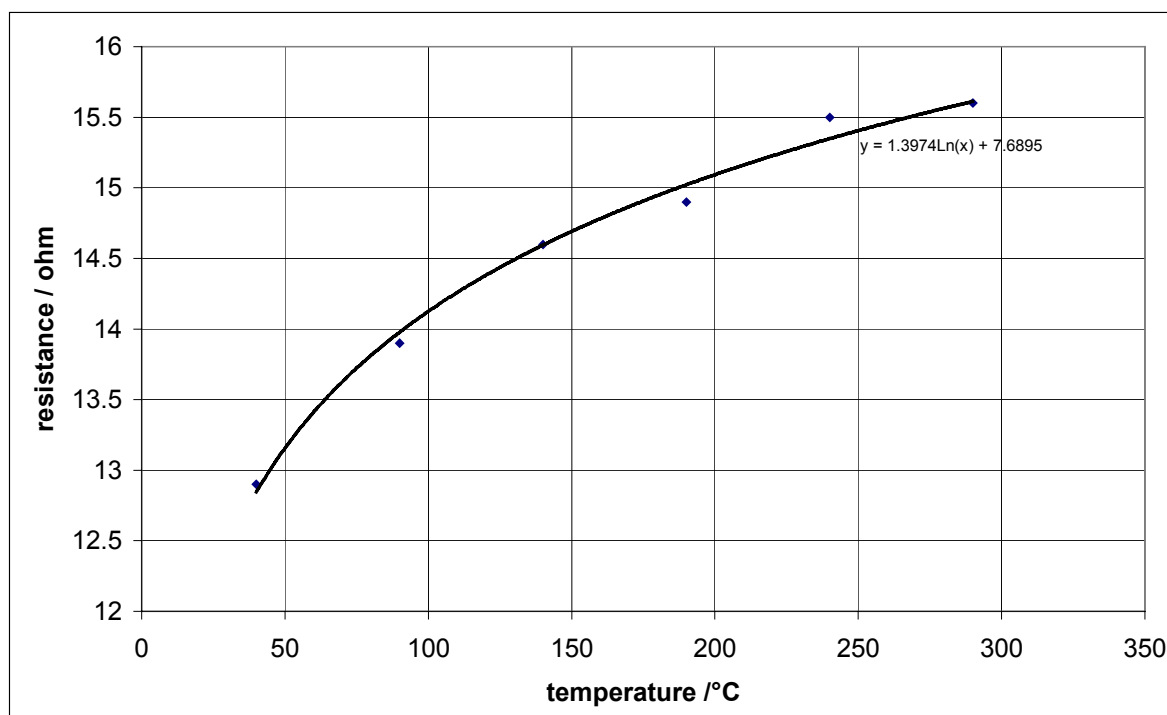

Noise was a bigger problem here than with the preceding circuits because two voltage readings were taken. One reading was taken for current calculation and the other for column voltage drop. This effectively doubled the noise on the resistance value which is calculated from both measurements.

Another problem encountered was that the analog input at the higher end of the column needed to face the full 30V of the heating current supply. Since this board and most general types of analog input boards have an input limit of $\pm 10V$, a three to four times voltage divider was required to avoid saturation of the amplifiers. 30 Volts were also uncomfortably close to the maximum allowable voltage (40V) on the

inputs, at which these boards are likely to be damaged. When voltage dividers were used on the inputs not only the offset was divided but also the small difference in voltage drop due to the increase in resistance with the concurrent increase in temperature. For a 1 meter column the resistance only increased by about 1Ω from 12 to 13Ω for the temperature range of 40 to 250°C . Thus, the use of voltage dividers significantly reduced the sensitivity of the measurements.

Unfortunately, when a heating current was applied and it was attempted to simultaneously calculate the resistance from the voltage and current measurements, very strange results were obtained: The slope stayed constant for the first 1A where after resistance appeared to decrease with an increase in current (Figure 4-9).

Figure 4-9: Resistance appears to decrease with increased current.

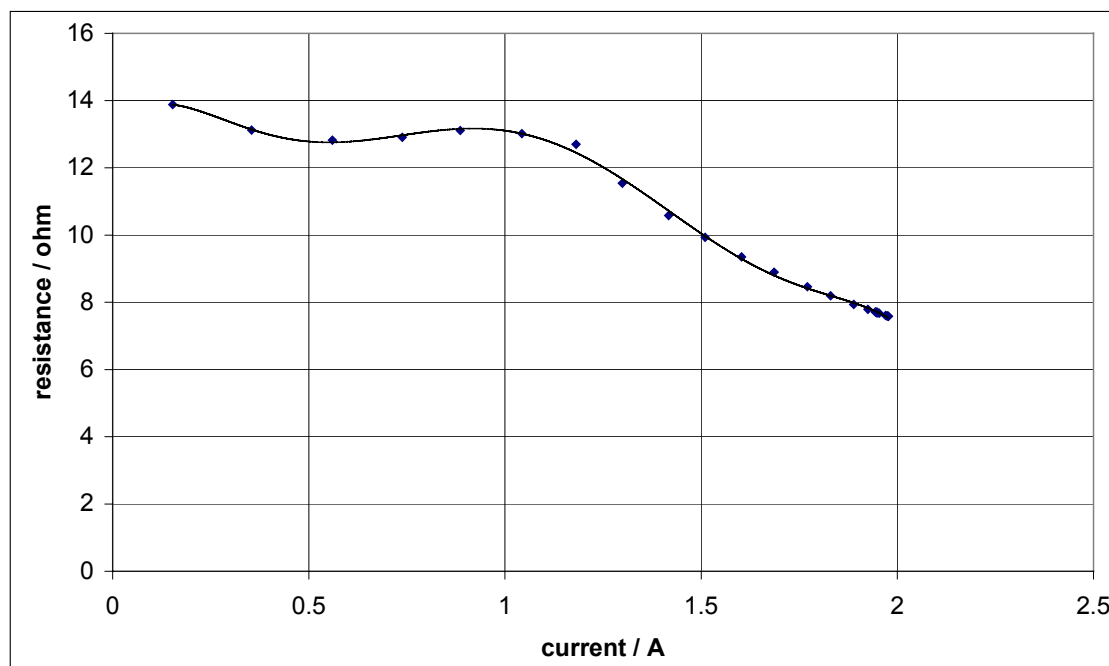

Despite numerous efforts to try and improve this result, which included using lower voltages across the column without voltage dividers, replacement of various components in the system, cleaning of the electrical contacts, etc, no solution has yet been found.

At this point further work with this circuit was postponed and the use of a micro-thermocouple described in the next section was investigated.

4.3.6 Thermocouples

4.3.6.1 Thermocouple basics⁹

A thermocouple is a floating signal source and has an isolated ground reference point. This point is the connection between the two wires at the measurement point. The potential difference between the two legs of the thermocouple is produced due to differences in the Seebeck electromotive force (emf) produced along the lengths of the two dissimilar legs of the thermocouple. The Seebeck effect concerns the conversion of thermal energy into electrical energy. While the Seebeck emf can be referenced to 0 K, in practice the measured emf is often corrected by junction temperature compensation (CJC). CJC is an emf value that is produced at the known temperature of a reference junction. The SCB-68 connector accessory provides automatic CJC when used together with National Instruments E series boards by sacrificing one analog input. LabVIEW has built in reference tables that make the use of thermocouples extremely easy.

The use of thermocouples for temperature measurement on fast resistively heated capillary columns could be considered impractical. The major objection to the use of thermocouples is the additional thermal mass added to the spot where the thermocouple is connected. Increasing the thermal mass means that more electrical power is required to heat the zone. When constant power is supplied across the length of the column this zone may be colder than the rest of the column. A colder section has less resistance and will also heat at an even slower rate. The deciding factor in preventing a run-away situation under these conditions is how fast temperature can be equalized by conduction along the length of the column. Compounds can be trapped at this colder position in the column or peak tailing may result. Temperatures lower than the actual column temperature will be read by the thermocouple. However, to the best of our knowledge the use of thermocouples, directly on a GC column for temperature control, has not yet been reported on.

⁹ R.M.Park, H.M.Hoersch, Manual on the use of thermocouples in temperature measurement, Philadelphia: ASTM manual series MNL 12, Chapter 1

4.3.6.2 Very small thermocouples

Very small thermocouple wires have become commercially available. While these very small thermocouples can not currently be bought ready-made, we found an adequate success rate in preparing them in-house using the spot welding technique described in the Instrumentation Section 4.2.3.4. A well-prepared thermocouple has a diameter of only slightly more than 0.05mm. This is about the sum of the diameters of the two wires. The capillary column has a wall thickness of 0.25mm. This is significantly larger than the size of the micro-thermocouple.

4.3.6.3 Peak profiles in comparison to a stirred air bath GC

Chromatograms were obtained with the Varian GC and by the resistive heating method at the maximum programming rate (50°C/min) obtainable with the Varian. Figure 4-11 and 4-12 show that earlier eluting peaks, up to hexadecane, display good retention-time correlation. Later eluting peaks, however, tend to exit the column much sooner with resistive heating than when the GC oven is used for heating. It has to be pointed out that the Varian doesn't follow the set ramp rate very well when the maximum rate is used, either¹⁰. This may result in an over-exaggeration of this anomaly.

Figure 4-11: Chromatogram of C10-C24 n-alkane with thermocouple controlled temperature ramp. A 1 meter column programmed at 50°C/min; H2 at 1m/sec

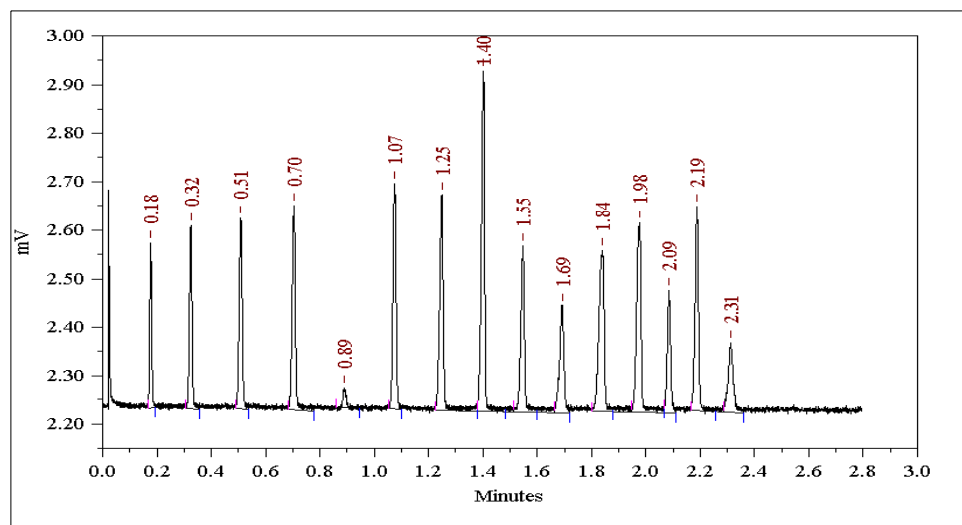
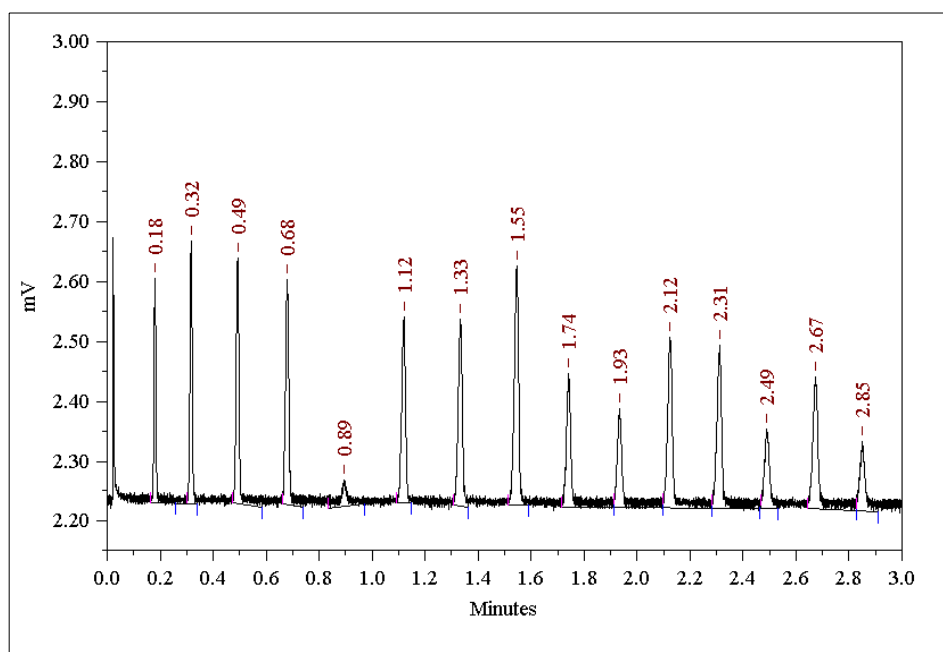

Figure 4-12: Chromatogram of C10-C24 n-alkanes with the GC oven controlling the temperature ramp. A 1meter column programmed at 50°C/min;



4.3.6.4 Thermocouple placement

No peak distortion such as tailing is discernable from the chromatogram (Figure 4-11) and it is unlikely that a significant cold spot was formed by thermocouple placement. While the additional thermal mass was compensated for by heat conduction along the column, the measurement of the thermocouple did not accurately follow the capillary temperature at higher temperatures. The higher the temperature differential between the column and the environment, the faster heat is lost to the cooler surroundings. The thermocouple, just slightly removed from the column for insulation purposes, reads a lower temperature. Sending this apparent low temperature value to the feedback loop in the current-control program (LabVIEW program 3.a) called for an increase in the current output through the column. This caused the true temperature to increase to above the measured value and resulted in peaks of higher boiling n-alkanes to move progressively closer to each other.

Additional non-linear calibration will be required after installation to ensure accurate temperature measurements at high temperatures. Since this retention time effect was reproducible, at least within the same thermocouple installation, it is unlikely to cause major complications for most applications. However for each new installation the

measurement elution temperatures for later eluting compounds will be slightly different.

Placement of the thermocouple has a strong influence on temperature measurement accuracy and thus, retention times vary from placement to placement. It was difficult to ensure that the thermocouple was always attached with the same droplet size of glue and that it was placed with the same amount of glue between the thermocouple and the column i.e. that it was the same distance from the column. The thermocouple needs to be electrically isolated from the column to protect the analog inputs from the 30V present on the column. Thus the above results can still be improved on if the thermocouple can be placed even closer to the column.

Figure 4-13: Two thermocouples placed and measured on the same column.

Top line: Set point;
Lower line: Thermocouple 1 (used for control);
Bottom line: Thermocouple 2 (read-out only).

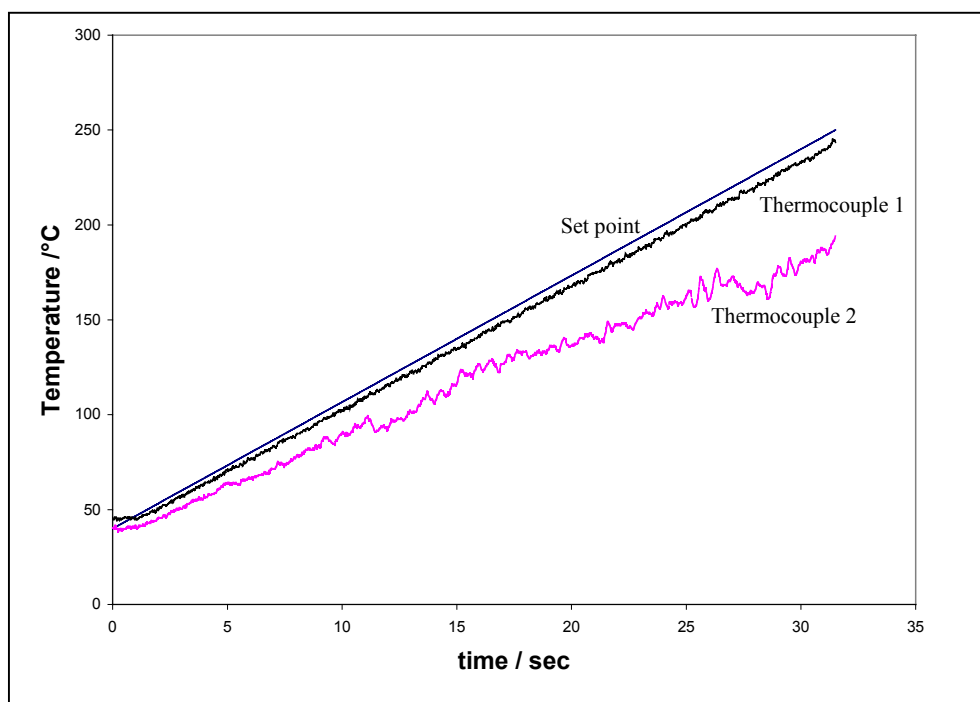

Figure 4-13 demonstrates the difference between two thermocouples placed and read simultaneously on the same column. Thermocouple 1 read a higher temperature than Thermocouple 2.

Note also the influence of the feedback control. Only the readings from Thermocouple 1 were used for feedback. This temperature appeared to follow the ramp with high

fidelity, as expected. Using a second, uncontrolled thermocouple illustrates that the temperature across the length of the column did not necessarily follow the ramp equally well. This creates the illusion of a smooth ramp profile because of the use of feedback on the thermocouple signal while the actual temperature may differ significantly from the set point. Some parts of the column may also have very different temperatures to the temperature at the point of measurement. Should thermocouple 2 have been used for temperature feedback control the reading of thermocouple 1 would have been above the set point and compounds would tend to elute earlier.

4.3.6.5 Stability problems

After prolonged continuous use, the polyimide glue became brittle from repeated heating and cooling cycles. The thermocouple junction was also weakened, possibly due to differences in expansion coefficients of the two wires.

Due to the minute diameter of the wires they are extremely fragile and almost invisible to the human eye. Thus it has to be considered normal to replace the thermocouple after any kind of maintenance work inside the host GC oven by even the most careful worker.

4.3.7 Fixed function without feedback

The control values from the computer during feedback controlled operation of many repeated ramps were recorded to obtain an average function. The coefficients had to be adjusted through an iterative process until the set ramp was followed with acceptable fidelity. This array of control values was sent to the current control circuit to obtain a temperature ramp that was applied to the column without feedback control.

4.3.8 Retention time reproducibility

Reproducibility data have been published using many different units. When %RSD is used¹¹ the standard deviation (SD) is divided by the retention time. This means that

¹¹ E.U.Ermann, H.P.Dharmasena, K.Carney, E.B.Overton, J.Chrom Sci. 34 (1996) p533

later eluting peaks appear to be more reproducible than earlier ones even when they are not in absolute terms.

Some authors provide reproducibility data as SD divided by the peak width¹². While the peak width defines what level of reproducibility is acceptable, other factors, not directly linked to reproducibility, are brought into account. This makes direct comparison between instruments with different column performances difficult, as poor retention time reproducibility may be obscured by poor column performance. It is the opinion of the author that the use of standard deviation should be encouraged as a primary means of reporting retention time reproducibility, as it is the unit least likely to obscure the facts and can be converted into any of the other units if additional information such as retention times and peak widths are provided.

Short term, run to run, reproducibility using the thermocouple is good and compares favorably with commercial instrumentation. Table 3 demonstrates that retention time reproducibility produced by the thermocouple system was about 2 to 4 times worse than for commercial instrumentation. However it was at least twice as good as other in-house manufactured, resistively heated GC instrumentation.

The influences of various factors on the retention time stability were investigated. Electronic noise originating from the six-port valve was measured on the thermocouple input with an oscilloscope. However, it did not have a significant influence on reproducibility, whether the valve was on or off. When a 20Hz low band pass filter was used instead of the 40Hz filter, used for the results obtained in Table 3-4, the average SD increased to 0.134. Changing the gain on the PID controller improved the SD for earlier eluting compounds, however, the average increased to 0.127.

Slightly better retention time reproducibility was obtained when a pre-defined function was used for the current ramp without feedback control. However, this approach is very inflexible because a new function had to be generated for each new combination of starting temperature and ramp rate. Great care needed to be taken to ensure that the conditions where the ramp was defined, exactly matched the

¹² J.Dalluge, R.Ou-Aissa, J.J.Vreuls, U.A.Th.Brinkman, HRC 22 (1999) p459

conditions when the ramp was applied. Any disturbance during the ramp produced unpredictable results. When a function without feedback was used to produce an SFCxGC_{fp} run, results were very poor. This was probably due to the difficulty in fixing the cryogenic starting temperature.

Table 4-4: Standard deviation of retention times in seconds

Alkane	Thermocouple Method 4	Function-no feedback Method 5	Collinear ¹¹ at-column heater	EZ-Flash ¹² 200°C/min	EZ-Flash 300°C/min
9				0.052	
10	0.073	0.078	0.57		
11	0.072	0.062	0.37		
12	0.080	0.049	0.42		0.075
13	0.072	0.041	0.39	0.048	
14	0.068	0.044	0.42		
15	0.071	0.045	0.28		
16	0.087	0.051	0.36		
17	0.107	0.052	0.27	0.052	
18	0.123	0.057	0.50		
19	0.129	0.071	0.45		
20	0.141	0.079	0.52		
21	0.143	0.087		0.040	
22	0.127	0.096			
23	0.105	0.107			
24	0.097	0.110			
26				0.040	
average	0.099	0.069	0.42	0.046	0.075

4.3.9 Optimization of ramp rate

Blumberg¹ suggested that an optimum ramp rate exists where an adequate separation of a required number of analytes can be attained in the shortest time. Furthermore, the temperature programming rate is a translatable quality and can be expressed as a rate

normalized to dead time. Thus, it is relatable to the carrier gas flow rate through the column. Finding the optimum separation conditions entails changing the carrier gas flow and temperature programming rate in a concerted fashion so as to maintain a constant normalized ramp rate. This requires calculation of the ramp rate for each new dead time obtained at the set flow rate. The aim is to maximize the peak capacity for a given column in the shortest available time.

Peak capacity was measured while maintaining the temperature-programming rate at $10^{\circ}\text{C}/\text{tm}$. Both flow rate and temperature-programming rate was changed for each data point. The values are reported in Table 4-5:

Table 4-5: Ramp, flow rates and peak capacity for H_2 at $10^{\circ}\text{C}/\text{tm}$

Programming rate ($^{\circ}\text{C}/\text{min}$)	Linear flow rate (cm/s)	Total analysis time (min)	Peak capacity
110	25	1.85	59
230	50	0.90	62
330	72	0.61	60
430	93	0.47	56
530	115	0.41	53
650	140	0.32	48
760	165	0.29	44
900	195	0.22	38

Hydrogen carrier gas at $10^{\circ}\text{C}/\text{t}_m$ demonstrates that the maximum in peak capacity can already be obtained at a total analysis time of 0.6 minutes. After this point it a plateau is reached. Figure 4-14 also emphasizes the need to exchange CO_2 for H_2 as mobile phase for fast GC in the $\text{SFC}\times\text{GC}_{\text{ftp}}$. CO_2 only approached the maximum peak capacity obtained by H_2 of $n_c \approx 60$ after more than twice the analysis time. This is to be expected, due to the associated higher resistance to mass transfer in the mobile phase. This can further be explained as a larger C-term in the Van Deemter equation context.

Note that the peak capacity was only calculated as the sum of peak capacities between decane and tetracosane. For the true peak capacity these values have to be extrapolated to include the separation space between decane and an unretained compound, adding approximately 12 peaks to provide a total of $n_c = 72$ in thirty seconds.

Most excitingly, the graph allows for the simultaneous optimization of program and flow rate, all in one.

Blumberg suggested $10^\circ\text{C}/\text{tm}$ as default for most applications. However a higher value of $18^\circ\text{C}/\text{tm}$ was indicated for low pressure drop conditions. The typical inlet pressures of between 1.1 and 1.4 atm, used with the 1-meter column, pertained to the low pressure drop region. Thus $18^\circ\text{C}/\text{tm}$ was also investigated. For H_2 it appears as if the maximum peak capacity obtainable was slightly lower at $18^\circ\text{C}/\text{tm}$ than at $10^\circ\text{C}/\text{tm}$. However, the performance normalized to analysis time (n_c/t_a) was higher. This correlates well with the published results¹. For both H_2 and CO_2 a marginal increase, less than 10%, was observed on the faster side of the trend line. This indicates that the optimum ramp rate is probably situated on a plateau.

The normalized ramp rate of 450°C and a flow rate of $100\text{cm}/\text{s}$ were found to be optimal. These conditions were used for the chromatogram depicted in Figure 4-15. It corresponds to a normalized ramp rate of $10^\circ\text{C}/\text{tm}$ and a peak capacity of $n = 72$. A ramp rate of $18^\circ\text{C}/\text{tm}$ requires faster actual ramp rates with a consequent decrease in reproducibility and ramp tracking fidelity (with present instrumentation), but without realizing a substantial increase in peak capacity at very short analysis times. Hydrogen carrier gas at $10^\circ\text{C}/\text{tm}$ demonstrated the maximum in peak capacity (or minimum in peak height) obtained at a total analysis time of 0.6 minutes. After this point, a logarithmic relation was no longer followed but a plateau was reached. This is the result of increasing peak widths due to longitudinal diffusion (B-term of the Van Deemter equation).

Figure 4-14: Peak capacity maximization by simultaneous optimization of flow and temperature programming rate.

■ CO₂ at 10°C/tm, ◆ H₂ at 10°C/tm, × CO₂ at 18°C/tm, ▲ H₂ at 18°C/tm.

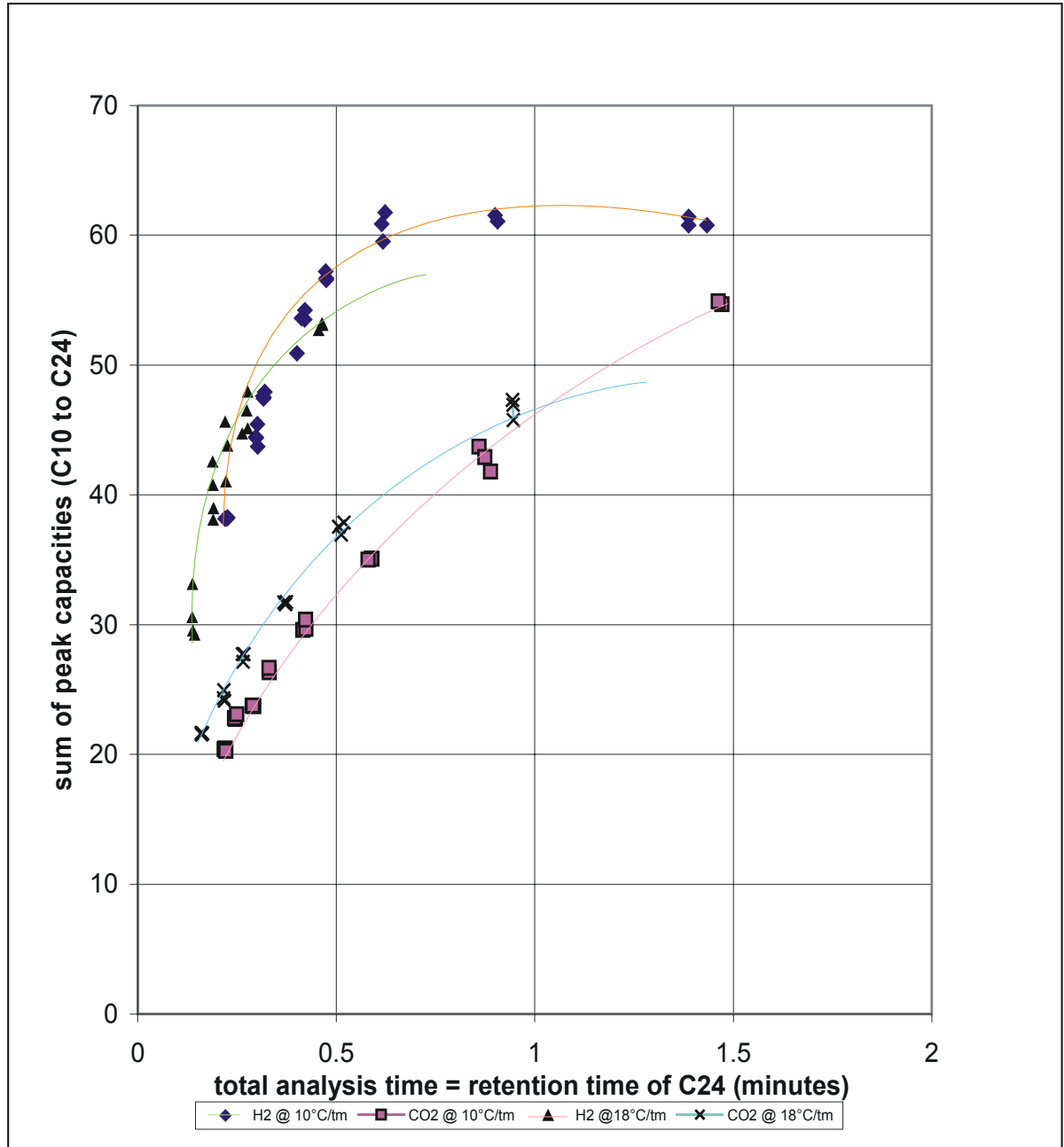
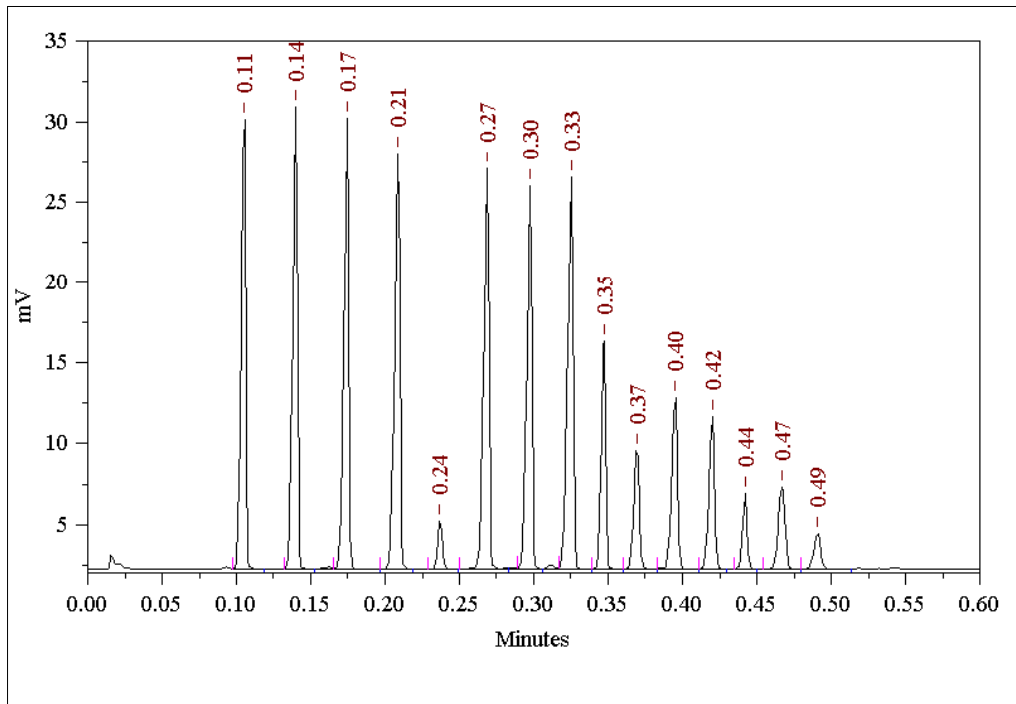

Figure 4-15: A typical chromatogram of n-alkanes of C10 to C24 at optimum conditions: 50°C to 300°C at 450°C/min and flow rate of 100cm/sec.



4.4. Conclusions

Measurement of the temperature through column resistance while simultaneously heating the column by continuously supplying current produced many problems: The measurement signal was small in comparison to the DC-heating current. This DC offset saturated the operational amplifiers on our analog to digital converter board. The sensing voltage could be electronically extracted from the DC heating current as an AC measurement signal. Alternatively, a voltage divider could be used to bring the measured signal back into the acceptable range of the amplifier. However, with a voltage divider, the sensing voltage was divided together with the offset voltage and this led to a loss in accuracy of temperature measurement.

These problems will disappear if pulse width modulation is used. Ermann et.al. , as well as the commercial Flash-GC instrument, uses PWM for temperature control. During the less noisy moment when the DC-current used for heating is momentarily switched off, the temperature can be more accurately measured. However, pulse width modulation requires faster acting electronics, as the heating modulation needs to be quite fast to ensure smooth ramp profiles.

Compared to the technical problems encountered with the other temperature measurement circuits, use of the thermocouple allowed for simpler temperature control. The lack of mechanical stability of micro thermocouples following repeated heating and cooling cycles and the general fragility of these wires were the greatest disadvantage.

Use of a commercial stainless steel column simplified the design and reduced GC cycle times due to faster cooling.

Results obtained with thermocouples compared reasonably to chromatograms obtained with conventional GC instrumentation. Retention time reproducibility also compared well with other resistively heated GC instrumentation. On average standard deviation of $SD=0.099$ seconds were obtained. It is still however, difficult to distinguish between a single peak and two closely eluting peaks in the 3D

chromatogram. (See Chapter 9). Thus ways to improve on retention stability should be sought.

The stability of thermocouples following repeated heating and cooling cycles and the general fragility of these microscopic wires, however, demand a more robust temperature measurement approach.

Ways should be found to measure the temperature independently from the heating circuit. To this end, either pulse width modulation or a separate sensing wire is suggested.

The use of a separate heating sleeve should be considered, as this will provide increased flexibility in the choice of stationary phases and columns dimensions. This will also facilitate the use of a separate sensing wire.

At a normalized heating rate of $10^{\circ}\text{C}/\text{tm}$ the maximum peak capacity of $n=72$ was obtained at a programming rate of $450^{\circ}\text{C}/\text{min}$ and a linear flow rate of $100\text{cm}/\text{sec}$. The maximum peak capacity decreased when a normalized programming rate of $18^{\circ}\text{C}/\text{tm}$ was used while the normalized performance increased.

Using H_2 as opposed to CO_2 the same separation number (55) could be achieved in one third of the analysis time (1.5 minutes versus 0.5 minutes), experimentally verifying the expected advantage of replacing CO_2 with H_2 in our SFCxGC interface. Alternatively, for 0.5 minutes hydrogen carrier gas provides almost twice as much separation number as CO_2 (60 versus 33).

Peak capacity versus analysis time curves at normalized temperature programming rates have apparently not been reported before and are a great tool in the practical optimization of fast temperature programmed GC.

Chapter 5

Supercritical Fluid Chromatography: Theoretical considerations

5.1 Introduction

In petrochemical analysis it is often not necessary to identify every compound in a sample. The boiling point distribution and group composition, e.g. aliphatic and aromatic groups or straight chain versus branched alkanes determine, to a large extent, the physical characteristics of fuels. The oxygenated group content of a fuel is another important parameter. It is believed that high oxygen content enhances fuel combustion and reduces harmful emissions, but oxygenates also end up as pollutants in water supplies. More effective ways of oxygenate analysis are required, both for fuel characterization and environmental monitoring.

Group selectivity and group resolution differs from the familiar definitions of selectivity and resolution. To obtain group resolution all members with the target functionality should elute close to one another without members of other groups in between. Quite often the resolution between individual members of a group is sacrificed. This type of separation is best achieved when the difference in polarity between the stationary and mobile phases is the greatest. Since polar mobile phases have impractical critical parameters, group separation is generally performed using a polar stationary phase. A very popular combination is packed column silica gel with sub-critical CO₂ as eluent. This separation of poli- aromatic hydrocarbons with SFC is an established method¹. With CO₂ as mobile phase, oxygenates and other polar compounds have unacceptably

high retention factors on silica gel. It has been shown that some oxygenates can be recovered when the column is back-flushed² but usually polar modifiers such as methanol are used to reduce the polarity of the stationary phase for oxygenate analysis. Unfortunately the use of modifiers precludes the use of a flame ionization detector.

This chapter provides background information on SFC in general and on group separation using packed polar columns. The ideas developed here are applied to both packed and porous layer open tubular columns in Chapter 6

5.2 Supercritical fluids defined

A supercritical fluid is a highly compressed gas that cannot be condensed into the liquid phase, yet with high density and therefore appreciable solvation strength. In more exact terms: A substance that is heated above its critical temperature and compressed above its critical pressure is said to be in the supercritical state and is referred to as a supercritical fluid.

When a liquid sample is heated in a sealed container, the density of the vapor increases because it is confined to a fixed volume. The density of the liquid decreases when heated until the two densities are equal and the interface between the two phases disappear. This temperature where the interface between the two phases disappear, is called the critical temperature (T_c). The corresponding vapor pressure is called the critical pressure (p_c)^{3,4,5}.

Figure 5-1 shows a temperature-pressure phase diagram of carbon dioxide.

The solid, liquid and gas phases are indicated. Below the critical point, phase transitions take place whenever, by changing the temperature or pressure, a solid line is crossed. Above the critical point the liquid and vapor have the same density and no longer exist as separate phases. A further increase in pressure will result in an increase in density but no phase transition will take place.

Above the critical point there is a continuous transition from liquid to supercritical fluid by increasing the temperature at constant pressure or from gas to supercritical fluid by increasing the pressure of a gas at constant temperature.

Figure 5-1: Phase diagram for Carbon dioxide.

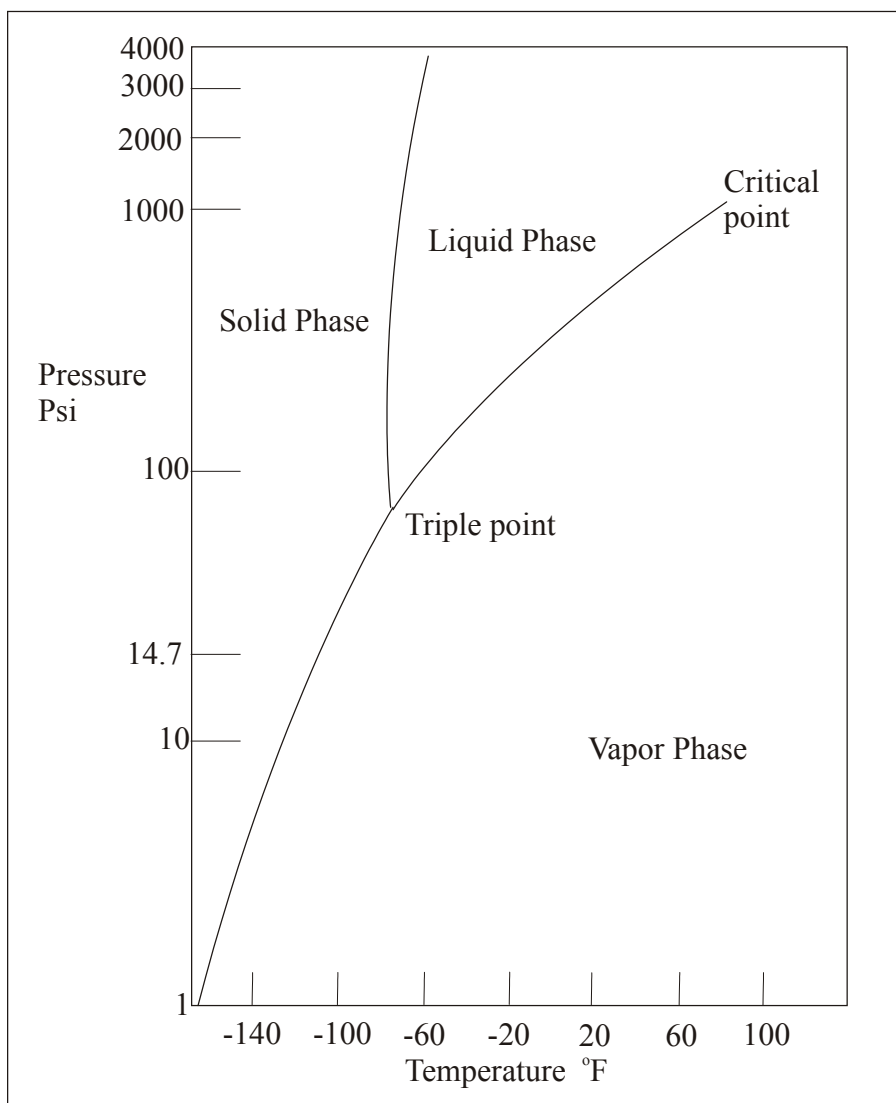

5.3 Supercritical fluids as mobile phase in chromatography.

Concise and useful information on the use of supercritical fluids as mobile phases in chromatography is available in the literature^{4,6}.

Properties such as solvation, viscosity and diffusion coefficients of supercritical fluids are intermediate between those of liquids and gasses, making SFC superior for some

separations despite kinetic advantages of gas chromatography and the greater flexibility of solvents available to HPLC.

Solvation, viscosity and diffusion coefficients in SFC depend on density, which is a function of the applied pressure and temperature.

5.3.1 Diffusion coefficients

Despite the fact that diffusion coefficients in SFC are closer to those of liquids than gases, much faster separation times compared to liquid chromatography can be achieved. Minimum plate heights for packed column SFC and liquid chromatography are similar except that the same plate height in SFC is reached at a faster flow rate.

Because of increased diffusivity of solutes in supercritical fluids compared to liquids, fast mass transfer between stationary and mobile phases allows much faster flow rates to be used before band broadening (column efficiency) becomes detrimental to resolution.

Column efficiency is related to flow through the Van Deemter equation, simplified as

$$H = A + B/u + Cu \quad [\text{eq 5-1}]$$

Where H is the total column efficiency also called the height equivalent of a theoretical plate (HETP), A arises due to the unequal lengths of flow channels in a packed bed and B is the contribution to band broadening due to longitudinal diffusion, C the contributions due to slow mass transfer and u is the flow rate. (Also see Chapter 3)

The greater the diffusivity, the faster the exchange of solutes between the stationary and mobile phases and the smaller the value of C . A small value of H implies a high number of theoretical plates. This increases resolution at high flow rates for SFC compared to the resolution in liquid chromatography on the same column.

5.3.2 Viscosity and pressure drop effects

High viscosities are responsible for high pressure drop due to flow resistance.

Gasses generally have very low viscosities so that the pressure drop across a column is inconsequential. Liquids experience a much higher pressure drop than supercritical fluids but, since liquids are virtually incompressible, this has little effect on separation. A large column pressure drop in SFC has the effect of decreasing the density along the length of

the column and increasing mobile phase linear velocity. A changing linear velocity means that the theoretical minimum in plate height cannot be achieved over the length of the column. An increase in pressure drop causes a decrease in density when pressure is controlled at the pump or an increase in density at the column inlet when pressure is controlled at the column outlet. In both cases, the capacity factors of solutes (k') change over the length of the column. Recent publications^{7,8} have found the effect of pressure drop on capacity ratios, selectivities and plate numbers to be negligible for most SFC systems. This was tested for pressures up to 300 atm and three 25cm packed silica gel columns connected in series.

5.3.3 Solvation

A solute in a chromatographic system is subject to a number of forces. In liquid and supercritical fluid chromatography the solvent competes with the stationary phase for interactions with the solute as it is swept along towards the exit of the column. In liquid chromatography the type of interaction and selectivity of separation can be controlled by varying the identity of the liquid. Solvent power depends heavily upon intermolecular distances, which depends on the density of the liquid. In the case of a liquid solvent the density is generally constant and the intermolecular distances of a specific solvent is fixed. Other factors that influence solvent - solute interactions are the polarizability of the solvent, the ability for a solvent to participate in dispersive and orientation interactions, to induce a dipole moment in surrounding molecules and to function as a proton donor or acceptor. Ideally in a comprehensive multidimensional approach only one of these interaction types should be active in a particular column or separation axis. In practice it is near impossible to obtain pure separation based on a single sample dimensionality (see Section 2-7) in any one axis.

The identity of solvents are also important for selectivity in SFC but since only a few compounds have critical parameters that are moderate enough to be useful and are unreactive towards solutes and instrumentation at these conditions, the choices are relatively limited. In SFC, because of high kinetic energy of molecules heated above the critical temperature, the molecular distances (density) can be controlled as a function of

pressure to be more liquid or gas-like. Since solvation is directly related to density, the solvation strength of a supercritical fluid is adjustable by density control.

The solubility parameter (δ) was first introduced by Hildebrand and Scott as a relative scale for solvent strengths. δ is a function of the cohesive energy density c :

$$\delta = c^{1/2} = (\Delta u^{evp} / v)^{1/2} \quad [\text{eq 5-2}]$$

where Δu^{evp} is the vaporization energy and v is the molar volume. Since the molar volume is inversely proportional to the density of the fluid, the solvent parameter will vary as the density varies.

This theory was extended by Giddings et al⁹ for use in supercritical fluids :

$$\delta = 1.25 P_c^{1/2} (\rho_r / \rho_{r,liq}) \quad [\text{eq 5-3}]$$

where P_c is the critical pressure(atm), ρ_r is the reduced density of the substance at the supercritical state and $\rho_{r,liq}$ is the reduced density of the substance in the liquid state.

Table 5-1: Critical temperatures, critical pressures and solubility constants at the critical state of fluids commonly used in SFC.

Compound	T_c ($^{\circ}\text{C}$)	P_c (atm)	δ (cal/cm^3) ^{1/2}
CO ₂	31.1	72.9	10.7
N ₂ O	36.5	71.9	10.6
Xe	16.6	57.7	9.5
SF ₆	45.6	37.1	7.5
Hexane	230.9	31.3	7.0

Group selectivity requires a maximum difference in polarity of stationary and mobile phases. Since polar mobile phases have very high critical parameters, polar stationary phases like silica gel and alumina are commonly used together with less polar mobile

phases for group separations. For maximum group selectivity, polar stationary phases have to be complemented with the least polar mobile phase.

Carbon dioxide is the most popular fluid used as eluent in SFC. It shows little FID response, is non-toxic, has moderate critical parameters and is relatively inexpensive. Yet it is perhaps not the ideal eluent for many separations. It is not the least polar fluid available nor is it polar enough to elute many functionalized analytes from polar stationary phases.

For CO₂ the solubility parameter is calculated to vary with density from 0 to liquid-like values of 10 (cal/cm³)^{1/2} at high pressures. This is explained by the fluid free volume. The closer the molecules are to each other, the higher will be the intermolecular interactions. While several researchers¹⁰⁻¹¹ found the solubility of carbon dioxide to be similar to hexane, Randall¹² found strong dipole selectivity tendencies. This was confirmed by Philips and Robey¹³ who added that CO₂ has proton acceptor properties.

Other fluids were also investigated as alternatives to CO₂ for group separation. Sulphur hexafluoride (SF₆)¹⁴⁻¹⁵ is a very weak solvent, less polarizable than CO₂. Separation of alkane and alkene groups without the use of a silver column was observed for samples in the gasoline boiling range¹⁶. FID detection was made possible by gold plating of the detector to withstand the corrosive action of hydrofluoric acid formed when the mobile phase decomposes in the flame.

Xenon shows comparable resolution of groups to CO₂, but has no IR absorption, providing superior Fourier transform infrared spectra of solutes¹⁷. However, this fluid was found too expensive for routine analysis.

Both these two gasses are less polar than CO₂, have moderate critical parameters (**Table 5-1**) and have low FID responses. However, both are very expensive compared to CO₂. Nitrous oxide is less compatible with the FID but was found useful for the reduction of tailing when resins are back flushed as the final step in crude oil analysis¹⁸ and might prove useful when sample components like amines react with CO₂.

5.4 Parameters affecting retention in SFC

Retention in SFC is a complex function of the experimental parameters and not as easy to explain as in gas or liquid chromatography. Retention in SFC is dependent on temperature, pressure, density, composition of the mobile phase and the stationary phase.

5.4.1 Density

The density of a supercritical fluid determines the solvation power. If there is an increase in density, then the solvation strength of the fluid is increased. This is similar to what is achieved in liquid chromatography by solvent programming using solvents with increasing solvent strength. One very important difference to solvent programming is that while the solvation power of the fluid is increased, the chemical selectivity stays unaltered. Only selectivity due to differences in solubility of analytes is affected, because only the number of molecules are altered and not their identity. Instantaneous density change over the length of the column is another difference to solvent programming but reminds one of temperature programming in gas chromatography. In fact one of the benefits of density programming is that for an optimized density program of homologs, later eluting peaks have the same width as earlier peaks in the chromatogram.

5.4.2 Pressure

While density is the fundamental property that influences solvation strength of a fluid, pressure is the physical property that is directly measured by supercritical fluid delivery systems. A number of papers^{19,20} have appeared that relate retention to pressure. Isothermal pressure programming is most often used to increase solvent strength during a run²¹. At a fixed temperature, when the pressure is increased, the solvent strength of the mobile phase increases as the density increases.

Pressure can be controlled before or after the analytical column. With most SFC instruments the upstream mode is used. This means that the pump delivers a continuous flow of fluid, at the set pressure, to the front of the column. With the fixed restrictors commonly used, an increase in volume flow is observed when a positive pressure program is applied. Inter-diffusion coefficients decrease with an increase in pressure⁹,

making the faster flow rate unfortunate. The increased flow increases the pressure drop over the column so that the exit pressure is lower than the set pressure.

Modern instruments offer pressure control before the column for capillary and narrow bore packed columns as well as pressure control after the column²² for larger diameter packed columns. In the latter case with pressurized UV detectors a variable restrictor that can be configured before the column in the upstream mode or after the column for the downstream mode allows for independent control of flow rate and pressure.

5.4.3 Temperature

Temperature does not only influence diffusivity of solutes but also the retention mechanism. The influence of temperature on retention is a function of free energy changes in the interaction between the analyte and the stationary phase²³. This can have a major effect on the selectivity of the system.

An increase in temperature at a fixed pressure causes the solvation strength of the fluid to decrease as the density decreases and this in turn increases the retention times. At higher temperatures more gas chromatography like mechanisms are observed and the volatility of solutes play a bigger role in retention.

Increasing the temperature increases the diffusivity of solutes. This is one of the major advantages of SFC over LC and has a major influence on the optimum flow rate that can be used.

For density to appreciably change with pressure, the fluid has to be heated above its critical temperature. Some researchers reported that temperatures below the critical temperature are beneficial for petrochemical group separations with carbon dioxide as mobile phase^{24,25,26}. This is sometimes called subcritical fluid chromatography.

Group selectivity requires that the non-specific type interactions between the stationary phase and the saturated carbon chain be negligible but the specific induction interactions between the double bonds (or other functional groups) and the stationary phase need to be as strong as possible.

It has been shown²⁷ that the non-specific London type dispersion forces are independent of temperature. On the other hand the orientation forces experienced by unsaturated π -systems due to the dipole of the hydroxyl groups on the silica gel stationary phase depends strongly on temperature according to the following equation:

$$E_k = -\frac{2}{3} \left(\frac{(\mu_1 \mu_2)^2}{r_d^6 k' T} \right) \quad [\text{eq 5-4}]$$

where

μ_1, μ_2 = dipoles of the solutes and the stationary phase

r_d = distance between dipoles

T = absolute temperature

E_k = interaction energy resulting from the orientation forces (after Keesom²⁸)

Thus, the orientation forces are weak at high temperatures and increases as the temperature is decreased. The best group separation should then be obtained at low temperatures where the orientation forces are maximized. This was demonstrated by Lee²⁴ who obtained the best resolution between docosane and toluene at 28°C (the lowest temperature studied).

Tagaki and Suzuki²⁶ investigated the influence of temperature on paraffin-olefin separation and found that the best selectivity (α) and resolution (R) of homologs differing only in number of carbon atoms were nearly independent of temperature, whereas the α and R of homologues differing in number of double bonds increased as the temperature was reduced. They concluded that separation by carbon number is controlled by entropy differences, whereas separation by double bonds is based on enthalpy contributions.

Squicciarini²⁵ confirmed these results by noting that at higher temperatures, separation was increasingly governed by boiling point. At temperatures as low as 0°C, he observed a

substantial decrease in resolution due to peak broadening. He too, suggested the use of 29°C as optimum for group separation of gasoline and jet fuel samples.

5.5 Stationary phases used with SFC

Packed column SFC adopted the stationary phases generally used for liquid chromatography. These include silica gel and other polar stationary phases, reversed phase columns, size exclusion and columns made of chiral selectors. While the solvent strength of supercritical fluids can be adjusted when the fluid is heated above its critical temperature by changing pressure, the choice of practically useful fluids for packed column SFC is limited by the low temperature stability of many HPLC stationary phases (<80-100°C)²⁹.

Later, when SFC grew into the realm of capillary chromatography, the stationary phases that are commonly used for GC were adopted³⁰. For capillary SFC, analysis times are much longer compared to gas chromatography, due to the slower diffusion coefficients in the dense fluids. Thus, very narrow capillaries are called for. Typically columns with internal diameters less than 100µm are needed. Practical column dimensions of 50µm i.d. and lengths of 20 to 30m have been accepted as a good compromise between performance and ease of sample introduction and detection³⁰.

Reverse phase columns provide selectivity mostly due to non-specific London type interactions that are closely related to the size and hence the volatility of compounds and are therefore of little use for comprehensive two-dimensional SFCxGC_{ftp}. This is because the retention in GC is primarily governed by boiling point and use of reversed phase columns will lead to a high level of sample dimensionality correlation with a corresponding loss in peak capacity.

Apart from very polar stationary phases like silica gel, other stationary phases that show good promises for use in SFCxGC_{ftp} are chiral and liquid crystal stationary phases.

The comment has been made that the use of smaller diameter columns will increase the possibility of eluting very polar analytes with strong affinity for polar stationary phases. This was made on the premise that when the column surface area is decreased, the adsorptive activity of the column will decrease³¹. However in this statement the effect of the phase ratio (β) was neglected.

5.6 Using phase ratio (β) to reduce retention of oxygenates

The retention ratio (k') is an indication of the time solutes spends absorbed on the column material relative to the time they travel down the column. It is expressed as the product of the phase ratio (β) and the distribution coefficient (K):

$$k' = K \beta \quad [\text{eq 5-5}]$$

The 'stationary time' is determined by the relative strength of interaction between the solute and the stationary and mobile phases. This is expressed in terms of the relative distribution of the solute between the stationary and mobile phases:

$$K = \frac{C_S}{C_M} \quad [\text{eq 5-6}]$$

C_S = solute concentration on the adsorbent surface.

C_M = solute concentration in the mobile phase.

The distribution coefficient (K) becomes a thermodynamic quantity when the concentrations are multiplied with their respective activity coefficients. It can then be used to calculate the heat of interaction between stationary phase and solute through the temperature dependence of the retention times³². This can in turn be used to predict retention when the phase ratio is known.

With highly polar molecules like alcohols and carboxylic acids, strong hydrogen bonding is present with polar stationary phases like silica gel. Other oxygenated compounds such as ethers and carbonyl compounds are subjected to strong dipole-dipole and proton donor

and -acceptor interactions. This implies a large value for K with most of the solute adsorbed to the stationary phase at any specific time.

These compounds have very high retention factors on packed column silica gel columns where the β -value is also very high.

$$\beta = \frac{V_s}{V_m} \quad [\text{eq 5-7}]$$

V_m = the volume available to the mobile phase.

V_s = the surface area of the stationary phase

The strength of interaction with the stationary phase can be reduced by the competitive interaction of the mobile phase with the stationary phase, for example when methanol is added as a *modifier* to the CO_2 mobile phase. But this increases instrumental complexity and precludes the use of the FID.

As a novel, alternative approach, reduction of the retention factor by a dramatic increase in V_m with a consequent reduction in the phase ratio, will be theoretically described in this chapter.

Figure 5-2 shows the difference between the volumes available for mobile phase in the packed and PLOT columns. With a packed column only the open spaces between stationary phase particles are filled with mobile phase. For a PLOT column the large central volume contributes to the volume filled with the mobile phase and drastically reduces the phase ratio i.e. the ratio of stationary phase to mobile phase.

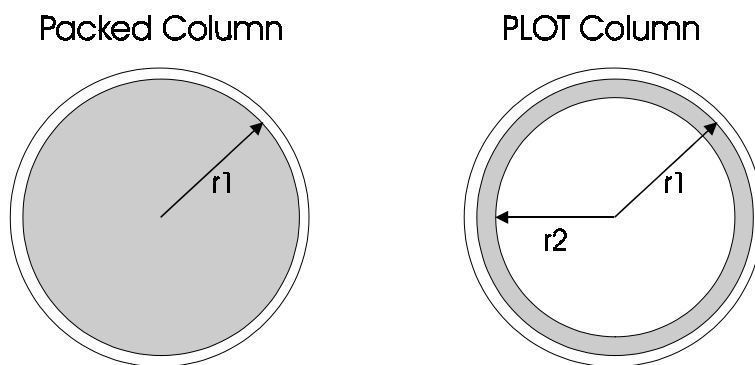
Figure 5-2: Phase ratios for Packed and PLOT columns

$$V_s = L\pi r_1^2$$

[eq 5-8]

$$V_s = L\pi (r_1^2 - r_2^2)$$

[eq 5-9]

$$\frac{V_{s,packed}}{V_{s,PLOT}} = \frac{L\pi(r_1)^2(1-V_m)}{L\pi(r_1^2 - r_2^2)} = \frac{(1.0)^2(0.7)\pi L}{(0.15^2 - 0.1485^2)\pi L} = 1563 \quad [\text{eq 5-10}]$$

$$\frac{V_{m,packed}}{V_{m,PLOT}} = \frac{0.3L\pi r^2}{0.3L\pi(r_1^2 - r_2^2) + L\pi r_2^2} = \frac{0.3(1.0)^2}{0.3(0.15^2 - 0.1485^2) + 0.1485^2} = 13.5 \quad [\text{eq 5-11}]$$

$$\frac{\beta_{packed}}{\beta_{PLOT}} = \frac{\left[\frac{V_{s,packed}}{V_{m,packed}} \right]}{\left[\frac{V_{s,PLOT}}{V_{m,PLOT}} \right]} = \frac{V_{s,packed}}{V_{m,packed}} * \frac{V_{m,PLOT}}{V_{s,PLOT}} = \frac{V_{s,packed}}{V_{s,PLOT}} * \frac{V_{m,PLOT}}{V_{m,packed}} = \frac{1563}{13.5} = 116 \quad [\text{eq 5-12}]$$

L is any length element along the column. We assumed particles to be spherical and close packed, thus an inter-particle volume of 0.3 times the volume of the column was estimated for the mobile phase volume. In equation 5-10 the volume of the stationary phase was calculated as the empty volume of the column minus the volume of inter-particle space occupied by the mobile phase. A fundamentally more correct estimation of the retention ratio improvement will be obtained if the stationary phase surface area was used for calculation as opposed to the volume of stationary phase. However these values

are not readily available especially for the PLOT column. Off course the volume of stationary phase particles is not fundamental in adsorption systems like silica gel. We merely imply that the volume ratio of stationary phases is approximately equal to the surface area or activity. Furthermore, the purpose was to illustrate the improvement due to the increased volume of mobile phase and especially the decrease in the amount of stationary phase, all other factors being equal.

Equation 5-8 to 5-12 theoretically demonstrates that retention factors are reduced **116 times** due to the effect of β . In the next chapter it will be experimentally verified that this reduction in k' allows polar oxygenated compounds to elute from silica gel and that it is possible to obtain group information normally lost when oxygenated compounds are back flushed from packed silica gel columns.

5.7 Conclusions

This chapter described the various ways in which resolution and analysis times can be manipulated in SFC. For many analysis schemes the optimum conditions are well researched and reported. For example, it is well known that for group separation with packed column silica gel, CO₂ below its critical temperature and at a pressure of about 150atm provides the optimum separation. This type-analysis of complex mixtures of chemical compounds will be very useful for comprehensive SFCxGC_{ftp} as it is completely orthogonal to the boiling point separation typical of GC analysis.

Furthermore we have theoretically shown that by reducing the column phase ratio the analysis time of polar analytes can considerably be reduced. It remains to be practically demonstrated that group separation of polar oxygenated compounds is possible on very polar stationary phases. This is partly the purpose of the following chapter.

Chapter 5

- ¹ Annual Book of ASTM standards, Vol 05.03. American society for testing and materials, Philadelphia (1991) Method ASTM D5186
 - ² A.Venter, E.R.Rohwer, J.Chomatogr. A 847 (1999) p309
 - ³ R.M. Smith. Supercritical fluid chromatography. London: The Royal Society of Chemistry (1988)
 - ⁴ M. Saito, Y.Yamauchi, T.Okuyama Fractionation by packed column SFC and SFE. USA : VCH (1994)
 - ⁵ P.W. Atkins Physical Chemistry. Oxford: Oxford University Press (1990)
 - ⁶ C.F.Poole, S.K.Poole, Chromatography Today, New York : Elsevier (1991) Chapter 6
 - ⁷ T.A.Berger, L.M.Blumberg, Chromatographia 38 (1994) p5
 - ⁸ U.Kohler, P.Biermans, E.Klesper, J.Chrom.Sci 32 (1994) p461and p525
 - ⁹ J.C.Giddings, M.N.Myers, L.McLaren, R.A.Keller, Science 162 (1968) p67
 - ¹⁰ P. Mourier, P.Sassot, M.Claude, R.Rosset, J.Chromatogr. 353 (1986) p61
 - ¹¹ J.M.Levy, W.M.Ritchey,HRC. CC. 8 (1985) p503
 - ¹² L.G.Randall , Technical Paper no 102, Hewlet Packard, Avondale,PA, (1983)
 - ¹³ J.H.Philips, R.J.Robey, J.Chromatogr. 465 (1989) p177
 - ¹⁴ J.W.Helgeth, M.G.Fessehaie, L.T.Taylor, Chromatographia,25(1988) p172
 - ¹⁵ R.M.Campbell,N.M.Djordjevic, K.E.Markides, M.L.Lee, Anal.Chem. 60 (1988) p356
 - ¹⁶ H.E.Schwartz, R.G.Brownlee, J.Chromatogr. 353 (1986) p77
 - ¹⁷ C.H.Kirschner, L.T.Taylor, HRC,17 (1994) p61
 - ¹⁸ E.Landanes, B.Iversen, T.Greibrokk, J.Chromatogr. 366 (1986) p391
 - ¹⁹ P.J.Schoenmakers, F.Verhoeven , J.Chromatogr. (1986) p315
 - ²⁰ Hanson, Chromatographia, 39 (1994) p431
 - ²¹ R.D.Smith, E.G.Chapman, B.W.Wright, Anal. Chem. 57 (1985) p2629
 - ²² R. Kornfield, American Laboratory (Sept. 1992) p25
 - ²³ B. Ooms, LC-GCInternational. September (1996) p574
 - ²⁴ M.S.Klee, M.Z.Wang, HP application note, 228-167(1992) Agilent, Avondale, PA
 - ²⁵ M.P.Squicciarini, J.Chrom.Sci. 34 (1996) p7
 - ²⁶ T.Takagi, T.Suzuki, J.Chromatogr. 625 (1992) p163
 - ²⁷ H.Rotzsche, J.Chromatogr. Library 48: Stationary Phases in Gas chromatography, Elsevier (1991) p80
 - ²⁸ W.H.Keesom, Phys.Z. 22 (1921) p129
 - ²⁹ R.D.Smith, C.R.Yonker, Anal.Chem. 60 (1988) p1323A
 - ³⁰ M.Novotny, S.R.Springston, P.A.Peaden, J.C.Fjeldsted, M.L.Lee, Anal.Chem. 53 (1981) p407A
 - ³¹ L.G.Blomberg, M.Demirbuker, I.Hagglund, P.E.Andersson, Trends in Anal.Chem. 13 (1994) p126
 - ³² N.Novakova, J.Novak, J.Chromatogr. 135 (1977) p13
-

Chapter 6

Supercritical Fluid Chromatography: Demonstration of group separation

6.1 Introduction

For many years group analysis of fuel samples were done with the laborious fluorescent indicator adsorption test (FIA)¹ or an equivalent thin layer chromatographic (TLC) method. These methods use fluorescent dyes to determine the paraffinic, olefinic and aromatic content of petrochemical samples. NMR² and MS³ methods are sometimes used but these methods are expensive to operate and require specially trained operators. Gas chromatography is well established for analysis of petrochemical samples with boiling points below 200°C⁴. While normal phase HPLC shows excellent group separation capabilities, it is hampered by the lack of a suitable universal detector. The use of CO₂ in SFC combines the group separation power of HPLC with the detection capabilities of GC, especially since the universal and very linear flame ionization detector (FID) can be used. In recent years SFC has become the standard technique for group analysis in petrochemical samples⁵.

This chapter demonstrates the use of the ASTM method D5186 of 1991 for PAH analysis and includes a comparison of data obtained with SFC and HPLC methods.

Although one-dimensional chromatographic methods have been proposed for oxygenate analysis, multidimensional methods are better suited for the complexity of petroleum samples⁶. In some instances, multiple columns are used. Here oxygenates are selectively retained in a polar column before being back-flushed into a non-polar column for alcohol and ether component separation⁷. Other methods apply multidimensional schemes through selective detection. Oxygen selective flame ionization (OFID)⁸, atomic emission

detection (AED)⁹ and Fourier transform infrared (FTIR)¹⁰ are examples. Recently, the use of comprehensive GCxGC was demonstrated for the separation of benzene, toluene, ethylbenzene and the xylenes (BTEX), alcohols and ethers¹¹. MTBE and several alcohols were successfully separated from a petrol sample and quantified. However, the separation of other ethers was hampered by co-elution with non-polar components.

In this chapter the novel application of a silica gel PLOT column to facilitate oxygenate analysis is proposed. With this method oxygenates can be separated into various subgroups including acids and di-ols. Oxygenates are analyzed on silica gel and the FID, without the use of modifiers or back flushing techniques, by altering the phase ratio (β).

6.2 Experimental

6.2.1 Instrumentation for packed column PAH group separation

The instrumentation used in this section was developed during the authors M.Sc. studies¹².

Figure 3-1: The Supercritical Fluid Chromatograph.

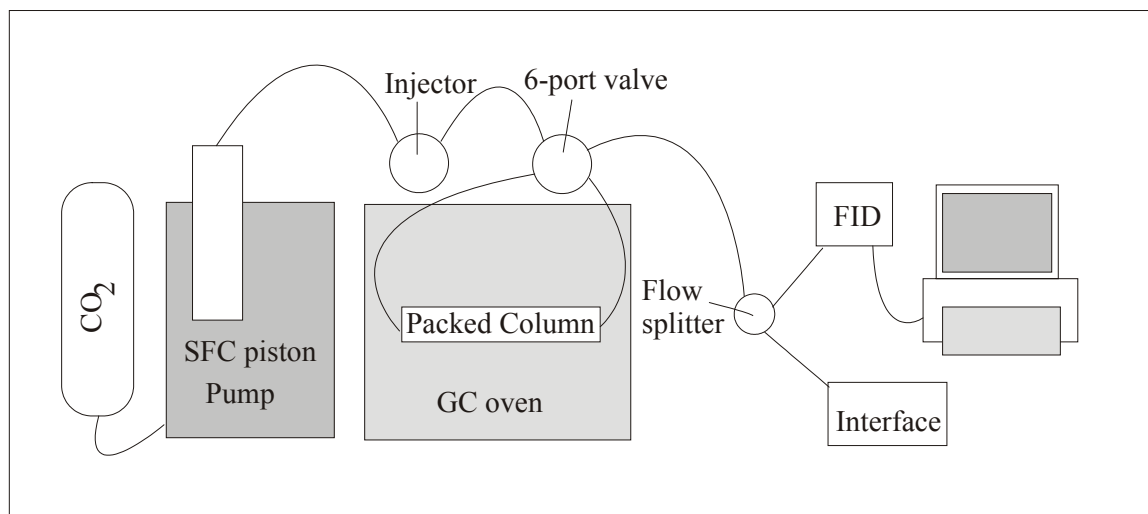

A supercritical fluid chromatograph (Lee Scientific 501SFC, Utah, USA) was used to deliver supercritical CO₂ (SFC grade, Air Products, ZA), without helium head pressure, to the 2.0mm X 250mm silica gel packed column (SFC group separation column, Hewlett Packard). Integral restrictors were used at the column exit to maintain the supercritical pressure conditions.

These were manufactured according to the process described by Guthrie and Swartz¹³. One end of a polyimide coated fused silica tube (50µm i.d. 350µm o.d.) (Polymicro Technologies, USA) was gently heated in a small high temperature glass blower's flame until it formed a conical closure. The restrictor is attached to the SFC and pressurized. The closure was gently sanded open with emery paper (no.500) until the desired flow rate was obtained.

Two restrictors were coupled to the column exit by means of a tee junction (Valco PN: ZT1C, Valco, Switzerland) to improve FID flame stability for group quantitation and to allow for off-line collection of separated groups. The column was connected to a six-port switching valve (Vici CW6-K, Valco, Switzerland) to allow back flushing to the detector. The isothermal column conditions were maintained by a PYE-Unicam GCD gas chromatograph with two FIDs. One FID was used for group quantitation while the other was only used to heat the second restrictor tip. These FIDs were designed for packed column GC and needed no alteration for SFC operation. The FIDs were maintained at 300°C. Chromperfect software (Justice Innovations, California) was used for data acquisition. An electrically actuated internal loop injector (Vici C14-W, Valco, Switzerland) with an 0.2µL internal loop was used for sample injection. All connections were made of 1/16" o.d. 120µm i.d. stainless steel (SS) tubing with electro-polished ends and connected with SS ferrules and connectors. A pressure of 150atm at 28°C was used for all experiments¹⁴.

6.2.2 Instrumentation for PLOT column separation

A Chrompack CPsil PLOT column was used for the analysis. The PLOT column was connected to a filter (Valco ZUFR1) by means of a two-piece removable fused silica adapter (Valco FS1.8-5). These adapters are made of graphite and were not very successful for the high-pressure work. PEEK adapters are also available and might work

better for this application. The filter was connected to a low dead volume two-way split connector. Two restrictors were glued into two pieces of electrolytic cut SS tubing with Epoxy glue. This approach was also used for the PLOT column connections when the fused silica adapters failed. The SS tubing was connected to the two way split with PEEK ferrules and 1/16" SS Valco nuts to form stable low dead-volume connections. One restrictor was connected to the FID on the Pye-Unicam packed column gas chromatograph.

A Valco injector with 0.2 μ L internal loop was used for sample introduction. This was connected to the PLOT column with a 20cm piece of electrolytic cut SS tubing through a butt connector.

High pressure liquid CO₂ was delivered from a Lee Scientific 501 pump. SFC grade CO₂ (Air Products) was used as mobile phase.

Initial experiments were performed at 150atm and 28°C, using the entire 30m column.

6.3 Results and discussion

6.3.1 Demonstration of the group separation of petrochemical samples using a silica gel packed column

The SFC system was tested according to the recommendations of the ASTM method and resolution between docosane and toluene of $R = 7$ far exceeded the required minimum resolution of $R = 4$.

Table 6-1 lists a comparison between the SFC method following the guidelines of ASTM D5186-91 and an established HPLC method. Very good correlation between the two methods was obtained except in the case of the Natref LCO sample. Here no clear distinction between the mono and di-aromatics could be observed. This type of sample would benefit from a multidimensional approach where the differences in boiling point should aid separation within this continuum of distribution on the polar separation axis.

Table 6-1 A comparison of the SFC and HPLC analysis of 4 Diesel samples.
Values are presented as mass %. (HPLC analyses by Sastech, Sasolburg, ZA)

Class	HT-SR		HX		Secunda DHT		Natref LCO	
	SFC	HPLC	SFC	HPLC	SFC	HPLC	SFC	HPLC
Aliphatic	99.93		99.86	98.61	69.65	70.19	22.57	25.37
Mono-aromatic	0.07	<1%	0.14	1.39	26.52	28.71	43.35	24.5
Di-aromatic					2.43	1.1	25.99	37.13
Poly-aromatic					1.4	0	7.14	13.0
Oxygenates							0.95	

The HPLC method could not analyze for oxygenates because in order to elute the very polar compounds, solvents of increasing solvent strength were added to the mobile phase. Typically methanol or acetonitrile is used and this masks the oxygenate peak. The results obtained with SFC shows that the Natref LCO sample was the only sample that contained an observable amount of oxygenates.

6.3.2 Investigations into the group separation achieved with the PLOT column

6.3.2.1 PLOT column oxygenate elution pattern

The inherent separation power of capillary columns prompted the investigation into the use of a silica gel PLOT column for petrochemical group separation. However, non-polar compounds showed almost no retention on this polar silica gel stationary phase. Even anthracene, with three benzene rings, was only marginally separated from the comparatively more volatile dodecane. (Figure 6-6). However the low retention of the PLOT column allowed for the elution of very polar oxygenated compounds.

From Figure 6-3 it can be seen that the silica gel PLOT column successfully segregated the oxygenated compounds from non-oxygenated compounds such as alkanes and polynuclear aromatics like anthracene (Figure 6-6). The oxygenate class was further separated into various groups e.g. aldehydes and ketones, followed by the alcohol group.

Carboxylic acids also eluted from the PLOT column. The tailing observed for the ethanol and the carboxylic acid was most likely produced by the strong hydrogen bonding interactions of the -OH moiety with active sites on the silica surface.

Figure 6-3: The elution order of some general groups with the Si-PLOT column and CO₂ at 150atm and 28°C.

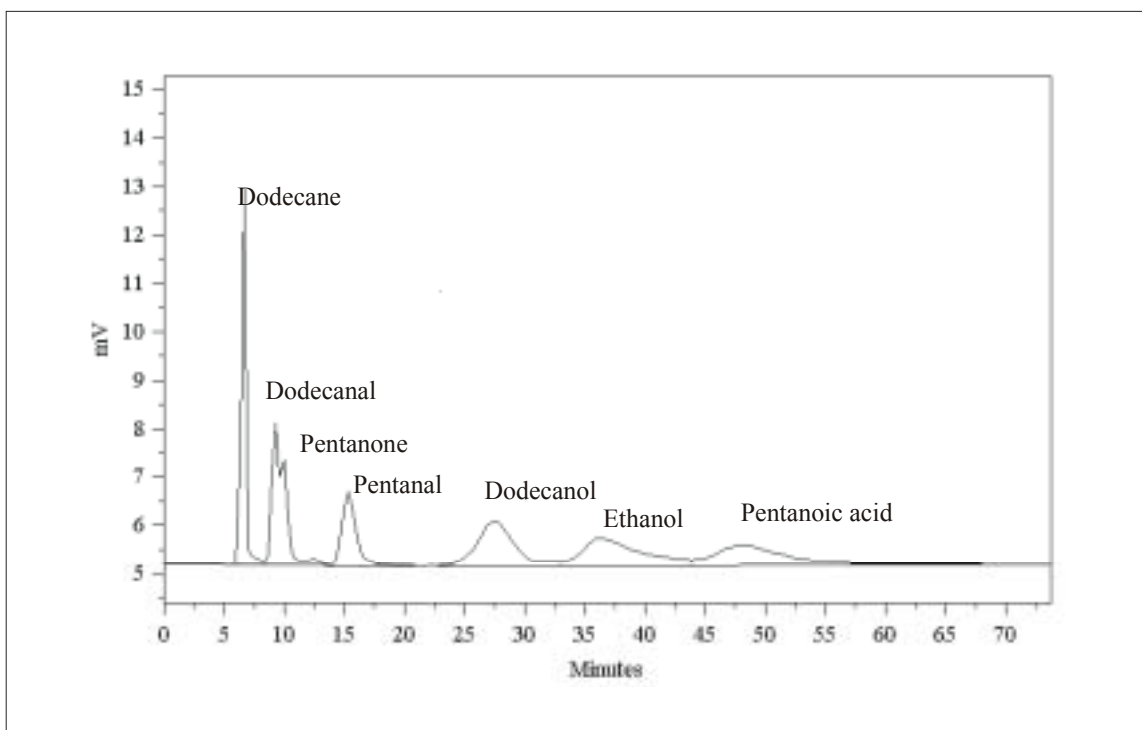

6.3.2.2 The influence of temperature on group resolution

Homologues of the same functionality are spread over a large retention time window. Those with higher boiling points elute later. Thus, it was thought that an increase in temperature might serve to reduce this spreading and focus individual groups closer together.

Unfortunately higher temperatures reduced the selectivity between the different groups and this lead to a loss in group-resolution. This correlates with the theory explained in Chapter 5.4.3 . Similar to the interaction with π -bonds, the specific interactions between the oxygenated groups and the hydroxyl groups on the silica gel surface are enthalpy controlled, while the non-specific London forces, that increase with molar mass of the homologue, is entropy controlled. Thus, an increase in temperature decreased the strength of the polar interactions and increased the relative contribution of vapor pressure to the retention mechanism, thereby reducing selectivity.

6.3.2.3 The influence of pressure on group resolution

Molecules of each group were chosen to represent a range of compounds that arbitrarily define a group. These molecules are called group boundary molecules. In Figure 6-4 dodecane (n-12) was chosen to represent the non-polar molecules.

Ethers, aldehydes and ketones elute in the same window and no pressure dependence on their group separation could be obtained. The resolution between dodecane and dodecanal (12al) was used as representatives for the non-polar and carbonyl separation. Methyl ethers elute later than ethers with long side chains on both sides. Thus, the separation between the alcohol group, here represented by the dodecanol (12ol) and the methyl ethers represented by MTBE (5e) was also demonstrated.

For both the ether-alcohol and ether alkane separation, group resolution seemed to decrease with an increase in pressure. This can be ascribed to the decrease in the capacity factor value as explained with the resolution equation in Chapter 3. The strong influence of pressure on the capacity factor and thus chromatographic resolution was surprising since the temperature of 28°C that was used is below the critical temperature for CO₂. This reminds us that near critical fluids also have some properties normally associated with supercritical fluids.

Figure 6-4: Group resolution of boundary molecules as a function of pressure

$R_{n12-12al}$ denotes resolution between the aliphatic and carbonyl groups.

$R_{5e-12ol}$ signifies resolution between the ether and alcohol groups.

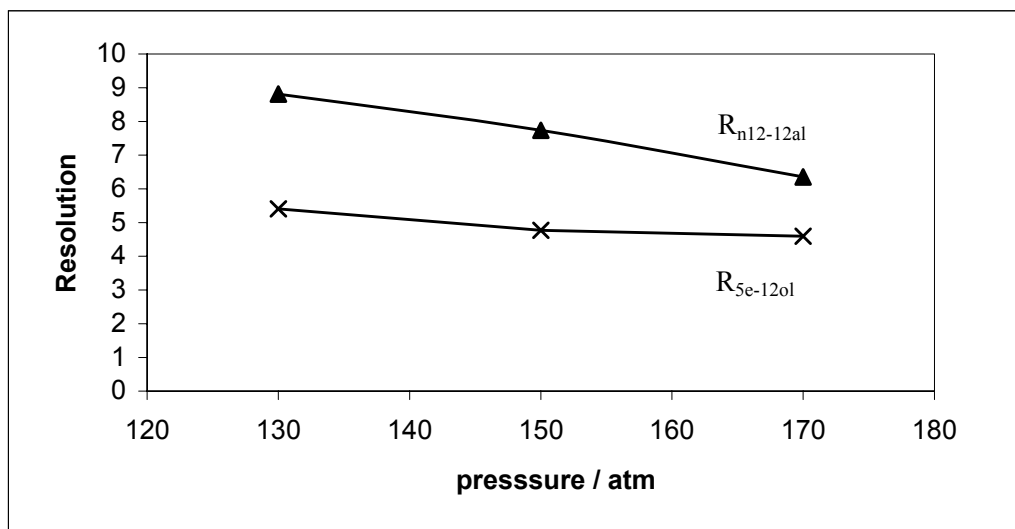

6.3.2.4 Comments on flow rates and runtimes

Most of the chromatograms shown here were obtained in about 1 hour. This was achieved by using very fast linear flow rates. The flow rate, measured as decompressed CO₂ gas at the column exit, was typically 480ml/min. This corresponds to a linear flow rate of 7.7 cm/sec.

According to theory¹⁵ the optimal average flow rate u_{opt} in GC is expressed as:

$$u_{opt} = \frac{4D_G^0 j(1+k)}{r} \left(\frac{3}{1+6k'+11k^2} \right)^{1/2}$$

Where

D_G^0 = mobile phase diffusion coefficient at outlet pressure

j = compressibility factor

k = capacity factor

r = column radius

The contribution to band broadening by diffusion into the stationary phase was neglected.

Diffusion coefficients are much lower in supercritical fluids compared to GC, especially at the high pressures used here. Typical values for solute diffusion in CO₂ approaching the liquid state is 10⁻⁴ cm²/s. Using this value for a compound with a capacity factor of k=2 it can be calculated that the optimum flow rate for this column should be as low as 1,6 x 10⁻⁴ cm/s.

It was attempted to obtain a Van Deemter curve. However even at analysis times of more than 9 hours, the minimum in plate height was not reached.

Figure 6-5: Van Deemter curve for a 0.3mm i.d. Silica gel PLOT column at 150atm

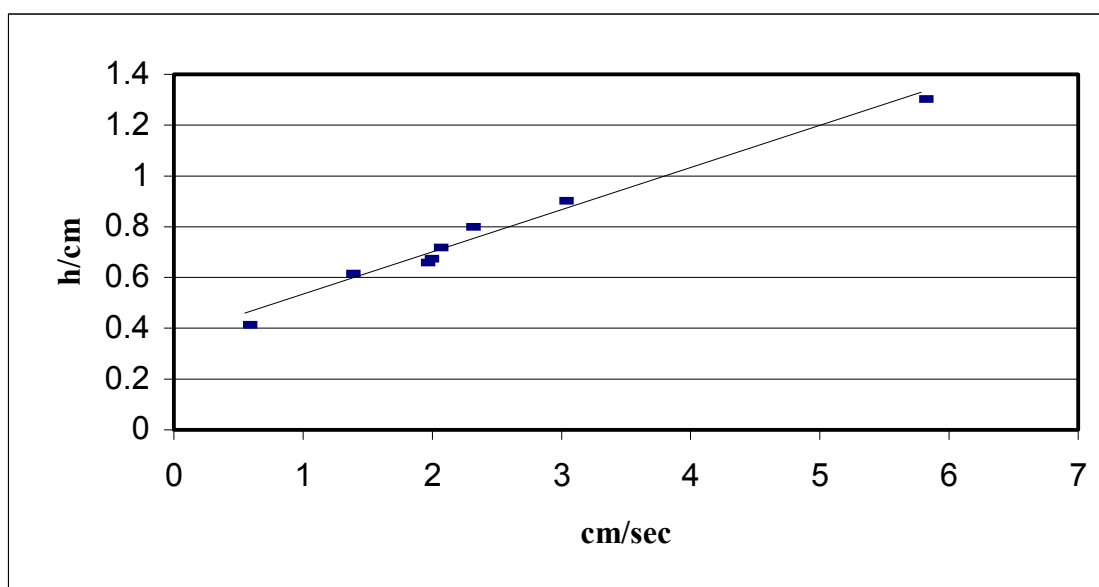

The application of mobile phase velocities, much above optimal is a general trend in capillary SFC¹⁶. The decrease in analysis time by the use of high mobile phase velocity can be justified by the large amount of excess resolution that was obtained. Compound specific resolution was not required since it was attempted to effect oxygenate group separation. This separation will be followed by a second boiling point analysis in the proposed SFCxGC_{ftp}.

6.3.2.5 Applications of the Silica gel PLOT column

Figure 6-6 shows the retention of compounds relevant to the petrochemical industry. Ethers elute in the same retention time window as the carbonyl compounds. The alcohols were very well separated from the ethers. Diisopropylether (DIPE) was separated from methyltert-butyl ether (MTBE) and tert-amylmethyl ether (TAME) but unfortunately TAME and MTBE were not well resolved at these pressures. Alcohols with near carbon numbers will also co-elute. A second separation, to analyze for the individual components of each group will be needed if compound specific analysis is required. Non-polar compounds were however unlikely to co-elute with ethers which is a major advantage over the previously described GCxGC¹⁰ method.

Figure 6-6: Separation relevant to the petrochemical industry

Conditions: 30m 0.35i.d. Si-PLOT column; Pressure 150 atm;
Temperature 28°C; Flow rate 7.7cm/sec.

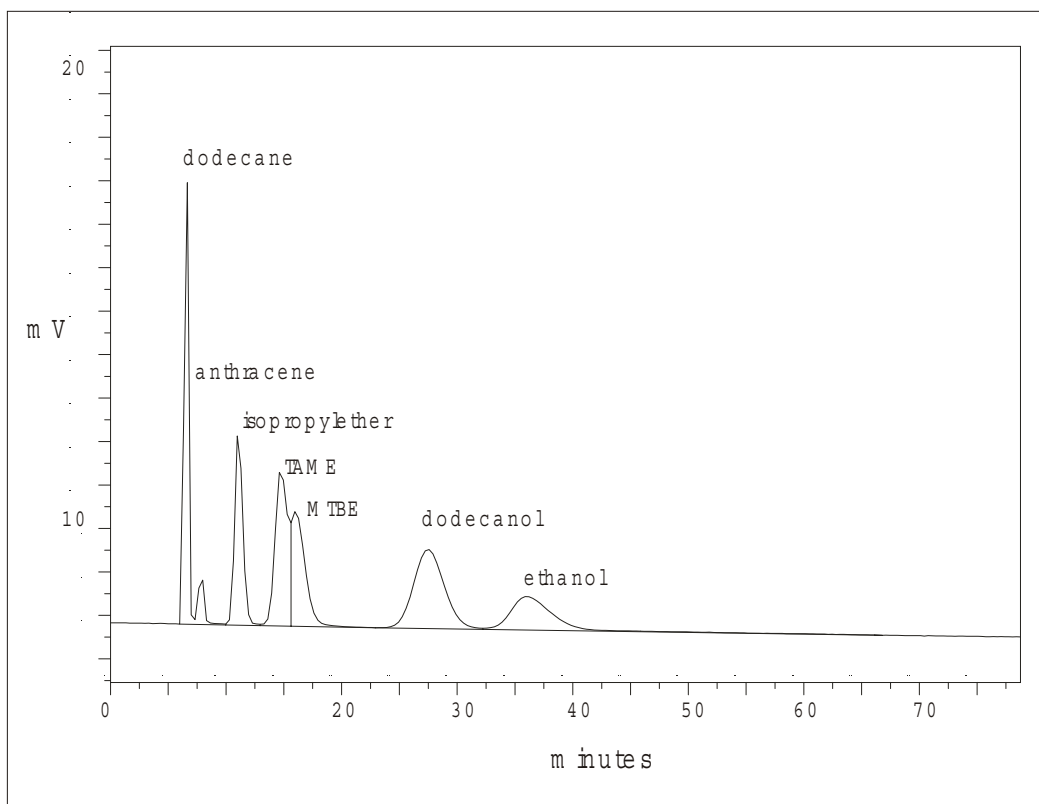

A commercial lemon essential oil was also analyzed. Compounds were clearly separated into various groups identified as esters, aldehydes and ketones and the alcohols. The groups were not baseline resolved at these pressure conditions. This analysis may benefit from using a lower pressure. However, as will be demonstrated in Chapter 9 when this separation was combined with GC in the SFCxGC_{fp}, a fast and efficient separation was obtained.

Figure 6-7: Analysis of a lemon essential oil

Conditions the same as for Figure 6-6.

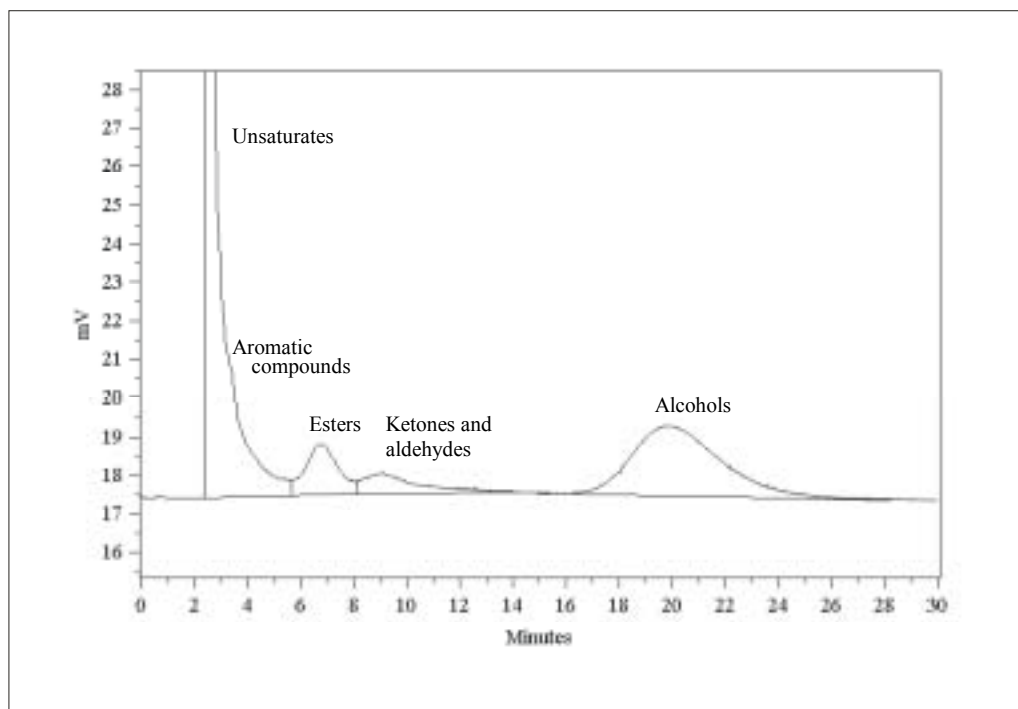

6.4 Conclusions

The results obtained with the packed column SFC method correlated well with those obtained with HPLC. Moreover, unlike with the HPLC method, quantification of the oxygenate group was also possible after the column was back-flushed following the elution of the other groups.

It was also demonstrated that when a silica gel PLOT column was used, oxygenated molecules could be eluted without back-flushing of the column. Oxygenates were further separated into groups of increasing polarity. Thus, the ethers, ketones and aldehydes were separated from the alcohols and the alcohols were separated from the oxy-acids.

The analysis of compounds pertaining to the petrochemical industry was demonstrated. Here the separation of the ethers from the methyl ethers and alcohols, without any interference from the non-polar molecules, are very promising.

The PLOT column was also applied to the analysis of a lemon essential oil. The sample was fractionated into four distinct groups. The groups were identified as the aliphatic and aromatic class, the esters, the aldehydes and ketones and finally alcohols eluted.

Both the packed column and PLOT group type analyses separated compounds according to polarity. This type of analysis is largely independent of boiling point especially in the case of the packed column. These two columns will thus be very useful for comprehensive multidimensional separation schemes where the second separation is based on volatility. This will be demonstrated in Chapter 9.

Chapter 6

- ¹ T.A.Norris, *Anal.Chem* 33 (1961) p1556
 - ² D.J.Cookson, B.E.Smith, *Energy Fuels* 4 (1990) p152
 - ³ T.Aczel, *Mass spectroemtry in the petroleum industry*, In : *Practical mass spectrometry*, Plenum Press, New York, (1979) p303
 - ⁴ J.Curves, P van Engel, *J.Chrom.Sci* 26 (1988) p271
 - ⁵ *Annual Book of ASTM standards*, ASTM D5186 Volume (1991)
 - ⁶ R.E.Pauls, *Adv.Chrom* 35 (1995) p259
 - ⁷ *Annual Book of ASTM standards*, ASTM D4815-94a Volume 05.02 (1997)
 - ⁸ *Annual Book of ASTM standards*, ASTM D5599-95 Volume 05.02 (1997)
 - ⁹ B.D.Quimby, V.Giarrocco, *HRC* 15 (1995) p108
 - ¹⁰ *Annual Book of ASTM standards*, ASTM D5986-96 Volume 05.02 (1997)
 - ¹¹ G.S.Frysinger, R.B.Gaines, *HRC* 23 (2000) 197-201
 - ¹² A.Venter, *Supercritical fluid chromatography combined with GC and GC-MS for the analysis of complex petrochemical mixtures*, M.Sc Thesis, University of Pretoria (1998)
 - ¹³ E.J.Guthrie, H.E.Swartz, *J.Chrom.Sci*, 24 (1986) p236
 - ¹⁴ M.S.Klee, M.Z.Wang, V.Giarrocco, *HP application note* 228-226 (1993) p1
 - ¹⁵ L.G.Blomberg, M.Demirbuker, I.Hagglund, P.E.Andersson, *Trends in Anal.Chem.* 13 (1994) p126
 - ¹⁶ L.Q.Xie, K.E.Markides, M.L.Lee, *Anal.Biochem* 200 (1992) p7
-

Chapter 7

The Modulator: Background and literature survey

7.1 Introduction

The fast GC and SFC instrumentation that were described in the previous chapters separate samples according to two different and independent types of selectivity. In order to combine these methods and harness the potential power of the comprehensive combination, a special interface is required. This interface must allow frequent sampling of the first analysis stream and provide fast, sharp injection bands for introduction into the second column. Furthermore, the physical state of the initial sample stream needs to be adjusted to make it compatible with the second analysis. These modifications include changing the state of the stream from being a supercritical fluid to a gas and exchange of the CO₂ gas with H₂. This chapter describes previous modulator designs available in the literature. In the next chapter, the necessary instrumentation for the coupling of the SFC and fast GC to produce a comprehensive two-dimensional chromatograph will be illustrated.

7.2. The modulator

The SFC and GC columns are connected together through a device called the modulator. The modulator is more than just a coupling between the two separation techniques. It is the heart of comprehensive multidimensional chromatography in that it provides a time base for each sequential second separation when it originates from the first dimension. It

also re-concentrates peaks that elute from the first column (SFC) and injects them as very narrow peaks into the GC at fixed time intervals.

Figure 7-1: Schematics of the SFCxGC instrument

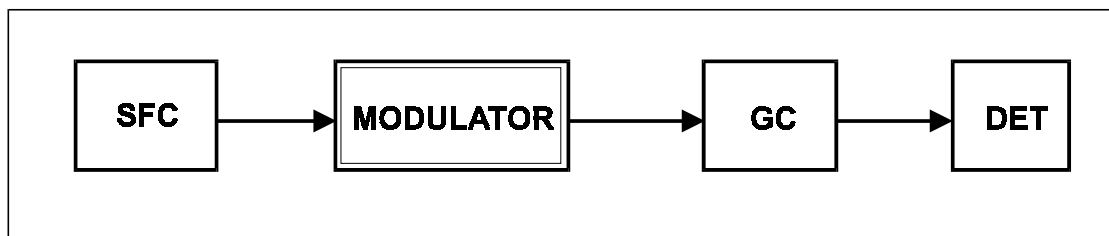

In other words, the injection time of each GC chromatogram can be traced back to a definitive retention time on the SFC chromatogram.

Figure 7-2: Function of the modulator

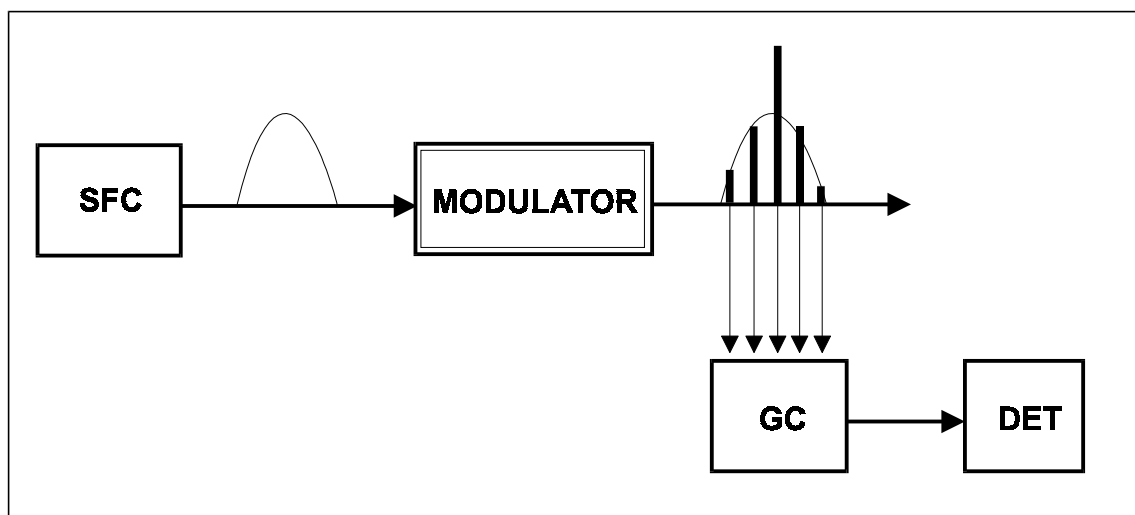

A modulator can further be distinguished from other transfer setups such as heart cutting devices, in that it transfers hundreds of 'heart cuts' during a run and feeds them into a very fast second separation step. Preferably the resolution and peak shape of the first separation step should be maintained. In our case of the SFCXGC_{ftp} it entails the transfer of at least 5-10 samples to the GC for every SFC peak. The SFC chromatogram is

analogous to a total ion trace obtained in mass spectrometry with each GC chromatogram representing a mass scan. Since the entire SFC chromatogram is transferred for subsequent analysis, the system is potentially far less sensitive to shifting retention times in the first column than repetitive heart-cutting techniques where shifts give rise to major complications.

In the ideal case, modulation is achieved by repeatedly increasing the retention factors of all sample components to infinity as they leave the first column. The trapped fraction is then released into the second column by instantaneously decreasing their retention factors to zero. In order to provide a fixed time base for the second separation step and to ensure good input bandwidth, no sample components should reach the second column unmodulated. This necessitates at least two focusing stages. (See Figure 7-3.)

A slice from a peak is collected by the first stage where the eluting components experience strong retention. The retention factors of the sample components are then decreased and sample components move to the second stage where they are once again focussed. At the same time as the first modulation stage collects sample components that are continually eluting from the SFC, the second stage launches the trapped analytes as a narrow band into the GC column for a very fast second separation.

Figure 7-3 demonstrates what happens when only one modulation stage is used: While the modulator desorbs the trapped components into the GC, more sample is bleeding unfocused onto the GC column leading to a bad injection profile. Unfocused volatile sample components that elute from the SFC during this time may overtake heavier molecules that are still being analyzed by the GC and cause 'cross-over'. This significantly complicates data analysis.

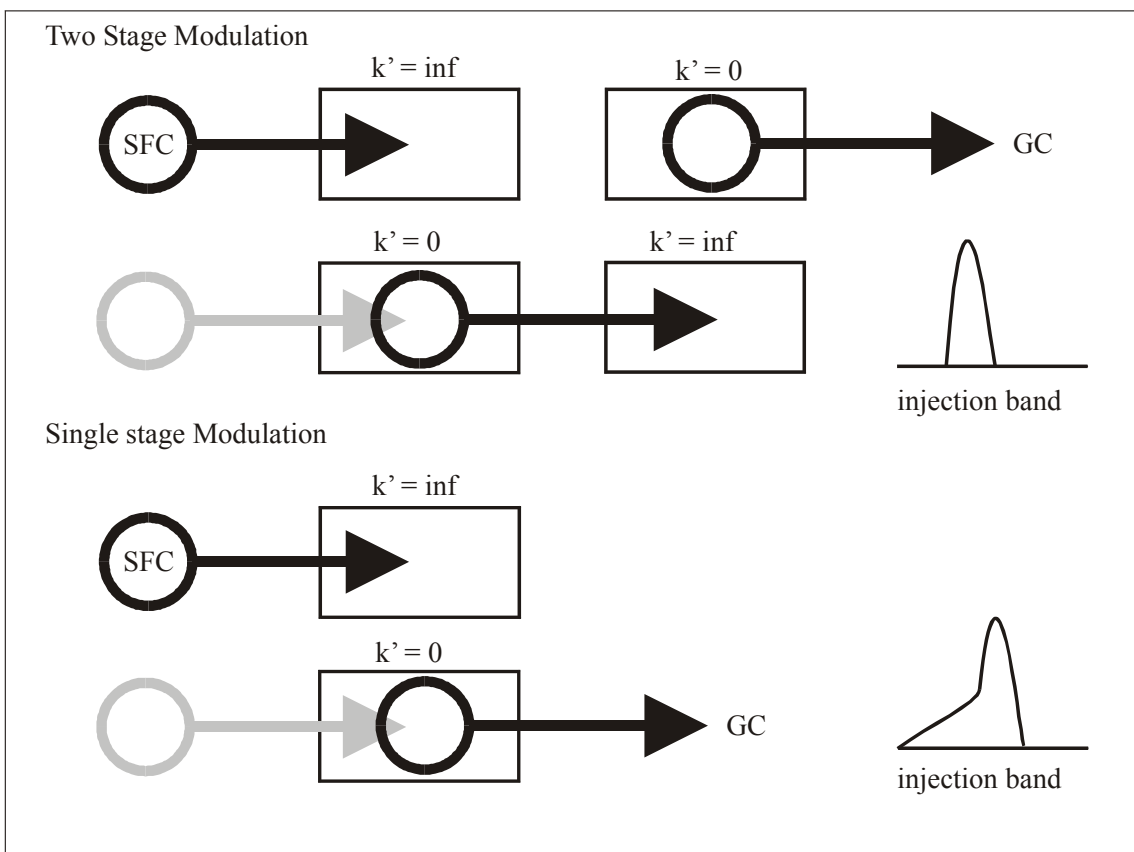
Figure 7-3: Two stages are required for modulation.

There are a number of ways to achieve the modulation of retention factors.

Diaphragm valves and stop flow conditions have been used as alternatives to methods that use modulation by retention factors. A wide peak eluting from the SFC can be sharpened into a narrow peak or a series of narrow peaks. Because of the law of conservation of mass the narrow peaks must have higher amplitude. This results in lower detection limits and improved quantitation¹.

Both stationary phase and cryogenic focussing techniques have been used for modulation.

7.3 Stationary Phase Focusing

Stationary phase focusing uses capillaries with a thick stationary phase film to decrease retention factors of volatile components at the ambient oven temperature. Additional heat is supplied at the modulation frequency to re-volatilize analytes in a focussed band. These analytes are then displaced into the second separation step by the carrier gas. This technique is generally known as thermal modulation.

The thermal modulator was originally developed as a sample injector for a technique called multiplex chromatography². With this technique the same sample was injected repeatedly and the resultant chromatograms were averaged to improve signal to noise ratios. The inventive step from multiplex to comprehensive multidimensional gas chromatography was to repeatedly sample the *changing* sample stream of an initial chromatographic separation developed by the first column.

The modulator was built from a thick film fused silica capillary tube that was coated with a resistive coating to make it electrically conductive. The tube was then alternatively heated and cooled down to produce a series of chromatograms. It was soon realized that a single stage was not adequate and a two-stage modulator was developed^{3,4}. This design ensured that no sample components reached the second column unmodulated (see Figure 7-3) and implied that a fixed starting time was realized for every injection into the second column.

The initial design, comprising of conductive fused silica tubes, had a low thermal mass and could be heated up and cooled down at high rates. However, these devices were not very stable or reliable and would suffer from unpredictable burnout⁵. This was due to the small thermal mass of the metal coating, which was hundreds of times smaller than the mass of the fused silica capillary that it needed to heat up. The power dissipation needed by the thin resistive layer to heat the capillary caused more thermal stress than what the materials could handle. Any irregularity in the coating would result in burn out. The modulator was modified in an attempt to improve reliability by inserting the capillary into a metal sleeve or by coiling heating elements around the capillary⁶. However these

modifications increased the thermal mass and resulted in slow cooling, effectively slowing down the process of GCxGC. It also proved difficult to attach low thermal mass electrical leads to the capillary without causing cold spots. Electrical connections need to have negligible thermal mass, and should not cause an increase or decrease of resistance at the site of attachment.

7.4 The sweeping arm thermal modulator

All these problems added to the movement away from resistively heated modulators to mechanically operated versions. A more robust thermal modulator was created without adding additional thermal mass when Philips and Ledford decided to apply an external, moving heated element to the modulator capillary. In the sweeping arm modulator, solutes are retained by stationary phase focusing and then volatilized by movement of a slotted heater over the stretched capillary. At the end of the sweep path, the stationary phase ended abruptly and solutes were launched into the second column for further analysis. The large thermal mass ensured stable and well-controlled temperatures. The sweeping movement of the element segregated a section of the first chromatogram, refocused and launched it as a narrow band into the second column. Typically 60ms injection peak widths into the second column were obtained⁷.

Close thermal contact between the heater and capillary is essential for fast local heating of the capillary but is also the downfall of this approach. Heating the capillary caused expansion and subsequent breakage as the slotted heater could no longer travel freely over the capillary. Difficulties were also encountered with connection of the modulator capillary to the two columns. Later configurations used the beginning of the 2nd dimension column as the modulator tube. Alignment between the stretched capillary and slotted heater was difficult and while some installations worked fine, others failed to produce acceptable results⁵.

Another disadvantage of this technique is that the modulator tube needs to be heated 100°C higher than the ambient oven temperature to ensure proper re-launching of focussed analytes into the second column. The polyethyleneglycol or carbowax columns typically used for the second dimension have relatively low maximum allowable temperatures. This reduces the final boiling point of the samples that can be analyzed.

7.5 The Cryogenic Modulator

An alternative way to effect stationary phase focusing was developed by Marriot and Kinghorn^{8,9,10,11,12}. They used a moving cryogenic trap to focus analytes on the second column. When the trap moves away from the zone where the analytes were collected the exposed capillary heats up to oven temperature within a few ten's of a millisecond. The small thermal mass of the capillary column ensures that this temperature is reached almost instantaneously. Since the analytes can migrate at the temperature used to bring the analytes into the trap, the heated part does not need to be warmer than the ambient temperature of the oven and no additional heating was required. The cooled section of the modulator tube was shielded from the oven fan by the cooling device, which facilitated rapid temperature reduction. To prevent ice build up and subsequent breakage of the capillary column, dry nitrogen was flushed between the cryogenic vessel and the trapping tube.

The inventors claim that the cryogenic modulator should function over a larger volatility range than the thermal modulators. The cryogenic trap should also focus lighter molecules more effectively. Using CO₂ as cryogen, analytes as volatile as hexane can successfully be immobilized. The maximum temperature is not limited by having to heat the capillary above ambient oven temperature. However, the injection bandwidth is determined by how quickly the trapping capillary heats up to oven temperature.

7.6 Diaphragm Valve Modulator

A gas-actuated diaphragm valve was used to sample the effluent from a wide bore column into a second, narrow-bore, column. Sampling was performed twice per second. To prevent immoderately fast linear flow rates in the second column, a portion of the flow after the diaphragm valve was diverted through a restrictor to waist. Splitting together with incomplete sampling of the sample stream impedes quantitative work with this system. Nevertheless chemometric methods were successfully applied to GCxGC with such instrumentation^{13,14}.

7.7 Non-mechanical modulators

Both types of modulators with moving parts have problems with mechanical failure, often resulting in breakage of columns. Future improvements will move away from modulators with moving mechanical parts.

7.7.1 Thermal modulation with hot and cold gas jets

In the latest commercial GCxGC version, streams of hot and cold gas are pulsed through jets to alternately heat and cool two short sections at the beginning of the second dimension column. This two-stage modulator uses high flow rates of nitrogen gas heated with a heating block close to the column for mobilization and cold air that passes through a liquid nitrogen dewar for trapping of sample components. Gases generally have a very low heat capacity and high flow rates are required. We found the total consumption of N₂ to be in excess of 450 L/hour.

Commercial prototypes are available operated with software written for the moving heater and have, with some effort, been successfully used in our laboratory to produce GCxGC chromatograms.

7.7.2 Resistive multi-segmented thermal-gradient modulator

A recent design again attempted to use resistive heating of up to 10 segments¹⁵ for modulation. The trapping tube is placed into a metal sleeve that is designed to have a close fit. Connections are made of the same material as the heating sleeve and silver-soldered in place. Successful multidimensional chromatograms have been produced with this modulator. Six stages are considered to be required for good modulation with this system. An advantage of many stages is that a thermal gradient can be created. (See the discussion on thermal gradients in Chapter 3.1). In a thermal gradient the front of a peak is at a lower temperature than the back. This allows peak compression to occur since the back of a peak catches up to the front and can potentially lead to very narrow injection bands. A major advantage of this arrangement is that large volumes of cryogens are not required for successful operation.

However, thermal gradients are generally not required when adequate focusing is attained in the trap and when it is ensured that remobilization occurs fast enough to not significantly contribute to the elution peak width.

Resistive heating of the metal sleeve does not suffer from the instabilities reported earlier for the painted capillaries since great care is taken to produce a homogenous sleeve. The separate sleeve is not affected by differences in expansion of fused silica and the metal. However, a close fit between the capillary and heating sleeve has to be ensured for good thermal contact.

7.8 Conclusion

While the different modulator designs produced results of varying success with GCxGC, none could be directly used for SFCxGC_{ftp}. The modulator in SFCxGC_{ftp} requires a different design because the two columns are operated at very different conditions. The modulator design is further complicated by the need for mobile phase exchange. The design of a modulator for SFCxGC_{ftp} will be demonstrated in the following chapter.

Chapter 7

- ¹ Z.Lui, J.B.Phillips, *J.Microcol.Sep* 6 (1994) p229
 - ² M.Zhang, J.B.Phillips, *J.Chromatogr. A* 689 (1995) p275
 - ³ J.B.Phillips, C.J.Venkatrami, *J.Microcol.Sep.* 5 (1993) p511
 - ⁴ J.B.Phillips, C.J.Venkatrami, US patents 5,135,549 and 5,196,039
 - ⁵ E.Ledford et al, *HRC* 22 (1999) p3
 - ⁶ H.de Geus, J.de Boer, U.A.Th.Brinkman, *J Chromatogr. A.* 767 (1997) p137
 - ⁷ J.Beens, J.Blomberg, R.Tijssen, *J.Chromatogr.A.* 882 (1998) p233
 - ⁸ P.J.Marriott, R.M.Kinghorn, *Anal.Chem.* 69 (1997) p2582
 - ⁹ R.M.Kinghorn,P.J.Marriott, *HRC* 22 (1999) p235
 - ¹⁰ R.M.Kinghorn,P.J.Marriott, *HRC* 21 (1998) p620
 - ¹¹ R.M.Kinghorn, P.J.Marriott, *HRC* 21(1998) p32
 - ¹² R.M.Kinghorn, P.J.Marriott,P.S.Dawes *HRC* 23 (2000) p245
 - ¹³ C.A.Bruckner, B.J.Prazen, R.E.Synovec, *Anal.Chem.* 70 (1998) p2796
 - ¹⁴ B.J.Prazen, C.A.Bruckner, R.E.Synovec,B.R.Kowalski, *J.Micro Col. Sep.* 11(1999) p97
 - ¹⁵ T.Snyman, *Ontwikkeling van instrumentasie vir omvattende tweedimensionele gaschromatografie*, PhD thesis, University of Stellenbosch, 2001
-

Chapter 8

The modulator:

Design, construction and characterization

8.1 Introduction

In normal GCxGC operation, an apolar column is used as the first separation step. Normally with GCxGC, both columns and the modulator are in the same oven, heated at the same rate. Boiling point separation is achieved as the oven temperature is ramped. Segments refocused from the first column contain compounds with very similar boiling points. A polar column is used as the second dimension but since analytes are of similar boiling point, separation takes place mainly due to differences in polarity. A small peak capacity is required for the relatively simple mixtures transferred to the second column.

With the proposed SFCxGC_{fp} the polar separation precedes the boiling point separation. The modulator transfers groups of similar polarity but varying widely in boiling point to a second column. The temperature of the second column is subjected to a very fast ramp to effect the boiling point separation. Thus the modulator also needs to be able to handle a wide boiling point range. Peaks eluting from the SFC are much wider than those from capillary GC and this provides some relief as far as the modulation frequency is concerned relative to other systems. More time is allowed for the second separation, however a large peak capacity is required in the second column to elucidate all components. The

modulator is in a different thermal zone from the two columns. The SFC is operated isothermally at 28°C and the GC is typically ramped from -50°C to 300°C and back down to starting temperature after each cycle.

A phase change from dense fluid in the supercritical fluid to the gaseous phase has to take place in the modulator. This is brought about by the restrictor that maintains high upstream pressure throughout the SFC column. Upon decompression after the restrictor, sample components fall out of solution and are collected inside the modulator through a reduction in pressure.

A large amount of gaseous CO₂ is produced when the fluid decompresses at the restrictor. As demonstrated in Chapter 3, CO₂ is unsuitable for fast GC operation. Thus, the modulator also needs to replace the CO₂ gas with a faster carrier gas, like H₂.

With GCxGC the second dimension is isothermal for each subsequent transfer. Hence, very narrow input bandwidths are required for each cut transferred to the second dimension. The injection bandwidth is less critical for SFCxGC_{ftp} because additional focusing is achieved before temperature programming of the GC column. Compounds are refocused on the GC column at the low starting temperature.

8.2 Suggested modulator designs

Modulators can arbitrarily be divided in two classes: Continuous and stop-flow modulators. The operation of two potential continuous flow-modulators and a stopped flow version are described in this section.

8.2.1 Two-stage continuous modulator with pressure modulation

This modulator design requires the use of two Deans switches (also called ‘live switching’ or valve-less switching’) connected in series. The device is schematically presented and the operation described in Figure 8-1.

The design illustrated in Figure 8-1 employs two areas that can be heated and cooled down sequentially. During one phase the area directly following the restrictor exit from the SFC T1 will be cold. During this phase, solenoid valve S2 is open and solenoid S1 directs hydrogen from P1 to position A. CO₂ from the SFC escapes through pressure relief valve P2 because of the directing effect at A by the slightly higher pressure provided by S1 while analytes are trapped by the cold zone. Analytes focused in T2 during a previous modulation cycle are desorbed into the GC by hydrogen flow from position A.

Figure 8-1: Gas exchange by Live Switching (Deans principle)

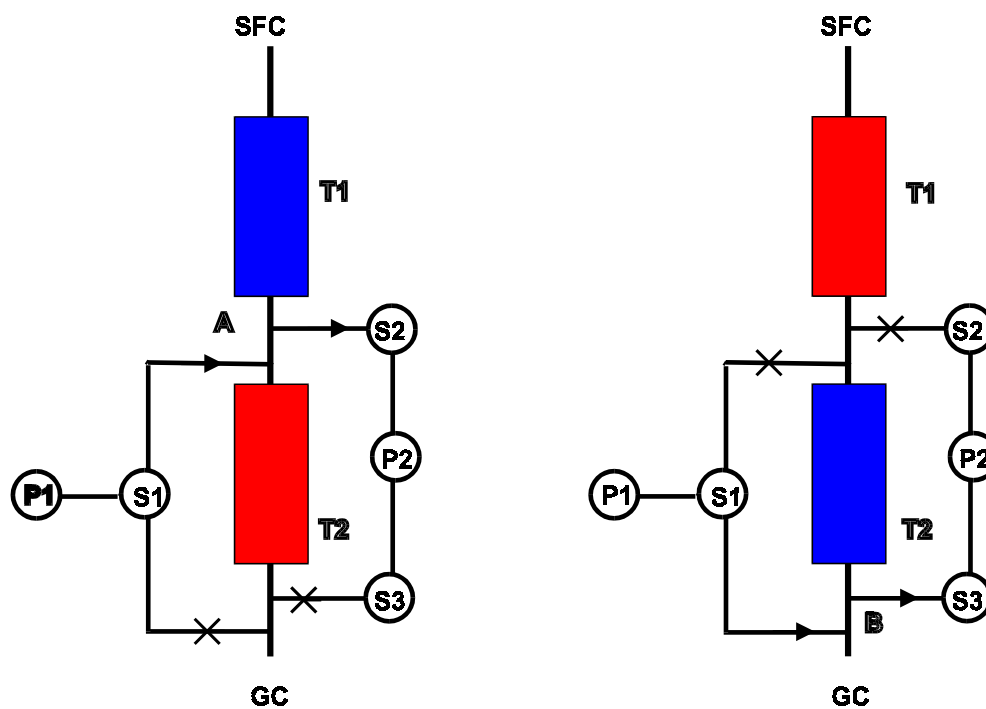

In the second phase T2 is cooled down. When T2 is cold T1 is instantaneously heated to desorption temperature while S2 is closed and S3 is opened. S1 directs hydrogen to position B and CO₂ from the SFC transfer trapped analytes in T1 to T2. The CO₂ then escapes through P2 because of the directing effect of the slightly higher pressure provided by S1 while the analytes are retained by T2. Alternatively modulation could also be effected with a single thermal zone and one valve-less pressure-switching step by leaving out T₁ in Figure 8-1. This is made possible by the focusing effect of the GC column at its low starting temperature. Operation is similar to that described above but with a single thermal zone. With reference to Figure 7-3, the skewed band of the single stage modulation will be refocused by low starting temperature of the GC column.

8.2.2 Stopped flow pressure modulation

The SFC analysis was allowed to progress, typically for 5seconds, where after the flow was stopped by a high pressure, low volume valve placed between the SFC column and restrictor. The SFC restrictor pierced through the septum of a split/splitless injector and the eluent was focussed on the head of the 2nd dimension column at the sub-ambient GC starting temperature. The split valve was closed during the 5-second collection time of SFC eluent. This allowed total transfer of sample components. Prior to the GC analysis the split valve was opened to relieve the CO₂ pressure that built up in the injector and 2nd dimension column due to the expanding SFC mobile phase. This facilitated the exchange of CO₂ with H₂. After concentration of analytes on the GC column, a five-second equilibration time was allowed for the pressure in the injector to normalize to the H₂ carrier head pressure setting of the GC.

The stopped flow modulator was built and used for all the SFCxGC_{ftp} experiments presented in this thesis.

8.3 Experimental

8.3.1 Hardware design

The SFC analysis was allowed to progress, typically for 5 seconds, where after the flow was stopped by actuating a six port valve (CW6-K, Vici, Switzerland) with all but two adjacent ports closed off. A simpler low dead volume valve would suffice. Valve switching was controlled with a TTL pulse from a multipurpose input/output board (PCI 6024E, National Instruments, Texas, USA). The valve was placed in between the splitter-restrictor assembly and the SFC column outlet (see Figure 8-2). The eluent was transferred to a split/splitless injector on the Varian 3300 through one of the SFC restrictors and focused on the head of the 2nd dimension column. The split valve was closed during the 5-second collection time of SFC eluent. The eluent cut was focused on the head of the capillary column at the sub ambient GC starting temperature. Prior to the GC analysis the split valve was opened to relieve the CO₂ pressure that builds up in the transfer interface and 2nd dimension column due to the expanded SFC mobile phase. The injector splitter was opened and closed with a solenoid valve controlled by TTL pulse from the computer. The entire column was cooled down to the ramp starting temperature with liquid CO₂ using the conventional sub-ambient temperature control of the Varian 3300. This allowed the oven fan and cryogenics to be switched on during sample collection and automatically switched off for the duration of the resistive GC analysis phase. External oven control was achieved through a small modification on the temperature control board of the GC as described in Chapter 4. After concentration of analytes on the GC column, a five-second-equilibration time was allowed for the pressure in the injector to normalize.

8.3.2 Demonstration of the interface

A packed silica gel column, similar to the one described in Chapter 4, was connected before the modulator. A standard solution, simulating a petrol sample, was injected. This solution contained the aliphatic group represented by the n-alkanes from octane to hexadecane, the mono-aromatic group represented by benzene, toluene and the chrysenes, and di-aromatics represented by naphthalene and methyl-naphthalene. Chromatograms of unmodulated and modulated runs were collected from the second FID. The comprehensive SFCxGC_{ftp} chromatogram for this standard obtained after modulation and GC separation is presented in the next chapter.

Figure 8-2: Schematic diagram of stop flow modulator.

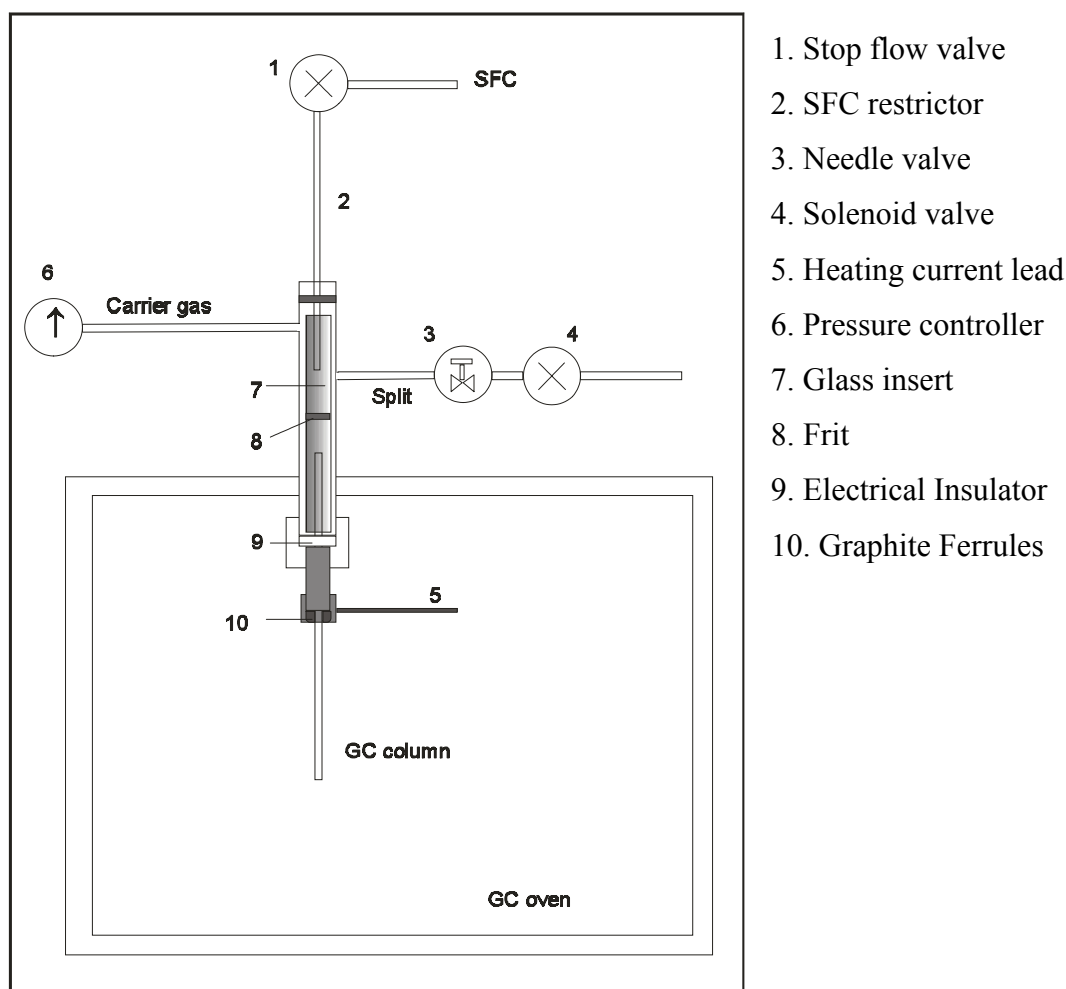

8.4 Results and Discussion

8.4.1 Number of modulation stages

The stop flow modulator is a two-stage modulator. The stop flow valve represents the first stage and prevents the elution of more sample components while the second dimension analyzes the previous fraction. Focussing is achieved by the second stage and this occurs due to the sudden pressure drop after the restrictor with concurrent loss in solvent strength of the SFC mobile phase. This is augmented by stationary phase focusing at the low starting point of the GC temperature program.

8.4.2 Run time of the modulated 1st dimension chromatogram

For packed column separation, as described in Chapter 6, an unmodulated runtime of 20 minutes was normal. The first eluting SFC peaks were typically 1 minute wide. To obtain 10 samples per peak, a 6 seconds modulation time was required. A typical GC cycle time of 1 minute and a collection time of 5 seconds increased the runtime to 200 minutes. This number of cuts was adequate to conserve the information contained in the first chromatogram and allowed for reconstruction of the SFC chromatogram from GC data points. At a fixed frequency of sampling, determined by the GC cycle time, the longer the sampling time, the faster the average SFC mobile phase flow rate. This lead to narrower SFC peaks and shorter analysis times. The GC cycle time is the sum of the sampling and equilibration times, the duration of temperature ramp and the GC column cool down time. The ramp time of the fast GC was optimized in Chapter 4. A further increase in peak capacity production per unit time with the current fast GC design is impossible without reducing the column diameter. However, metal columns with smaller internal diameters are not currently available.

The GC cool down time was facilitated by the host oven fan together with active cryogenic cooling with liquid CO₂. The capillary column typically cooled down to -50°C from 300°C in 25 seconds.

8.4.3 The influence of modulation on SFC flow rates

For stopped flow operation the linear flow rate in the SFC column was cycled between a fast value, maintained for 5 seconds and a no-flow period of up to one minute. A new 'virtual peak' can be calculated for the SFC analysis that is the average of the no-flow and the flow conditions. This is represented by peak C in Figure 8-3.

Chromatogram C is the peak that will be obtained by an instrument that uses continuous operation when a flow rate is chosen to produce a chromatogram of similar duration. The SFC flow rate for continuous operation can be adjusted, through use of the appropriate restrictor size, to be the same as the calculated average flow, obtained with repetitive stopped flow operation. This will produce the same runtime of 200 minutes and provide enough analysis time for the GC separation. The slower continuous flow rate will have a beneficial effect on the resolution when compared to stopped-flow operation. This can be explained at the hand of the Van Deemter equation:

The B term that describes longitudinal diffusion is the same for stopped flow and continuous operation because the total analysis times are of the same duration. The C-term decreases in direct proportion to the flow rate and will always produce a smaller plate height when a slower flow rate is used. With stopped flow operation, to achieve the average flow rate, the flow rate has to be faster when flow is allowed to compensate for the no-flow interval. Hence, flow rates are above optimum when the average flow rate is at the optimum. With continuous operation, a continual slower flow rate (equal to the average) is prevalent and can thus be chosen nearer to the optimum.

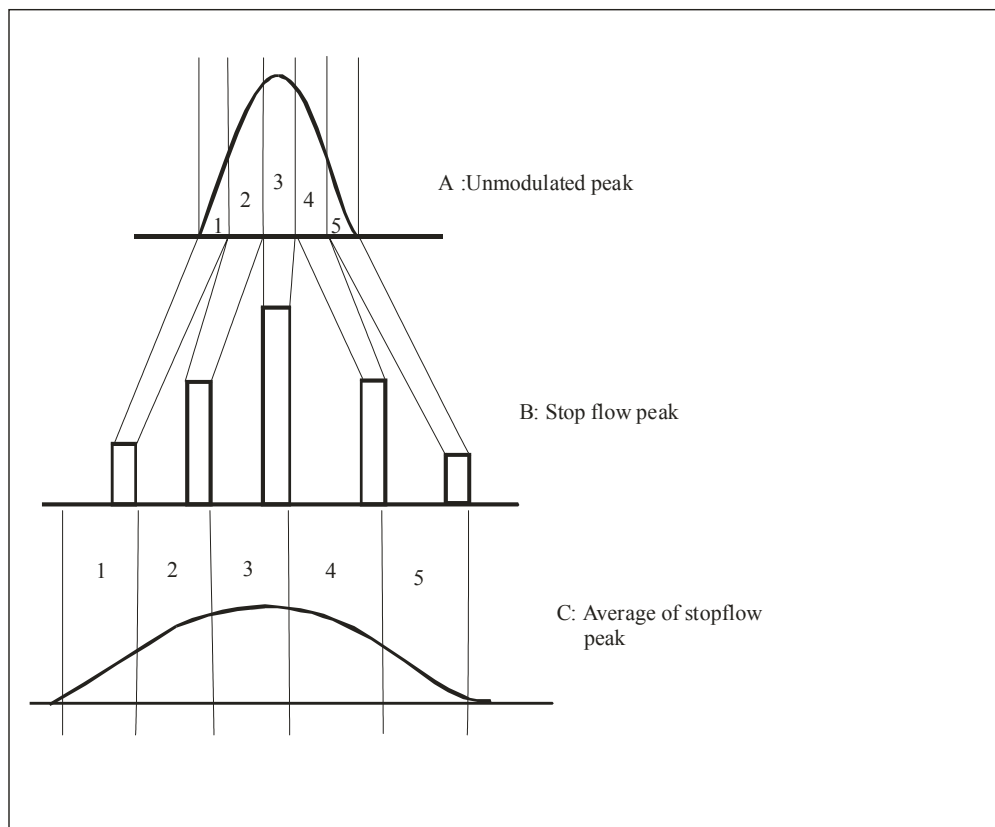
Figure 8-3: Unmodulated, stopped flow and the virtual peaks.

8.4.4 Advantages to the stopped flow interface

The use of a stop flow valve instead of continuous operation eliminates the need for thermal modulation in the interface. This simplifies construction and control. Removal of the excess CO₂ gas that forms when the SFC mobile phase decompresses is aided by separating the collection and second dimension analysis events. Also, the use of valve-less Dean's switches with a continuous interface requires cumbersome fine-tuning of the relative pressures for proper operation. This is not required for stopped flow operation. The stop flow valve also provides adequate and flexible separation space (time) for the second dimension to achieve high enough peak capacity and to satisfactorily elucidate the wide boiling point distribution of each cut.

Continuous operation will require that cut fractions be held in the thermal trap for up to a minute and may require unattainably effective trapping to prevent breakthrough.

8.4.5 Influence of stopped-flow modulation on the SFC chromatogram

Figure 8-4: Unmodulated SFC chromatogram.

Conditoins: Pressure=150 atm; Temperature= 28°C; Flow rate=120 ml/min

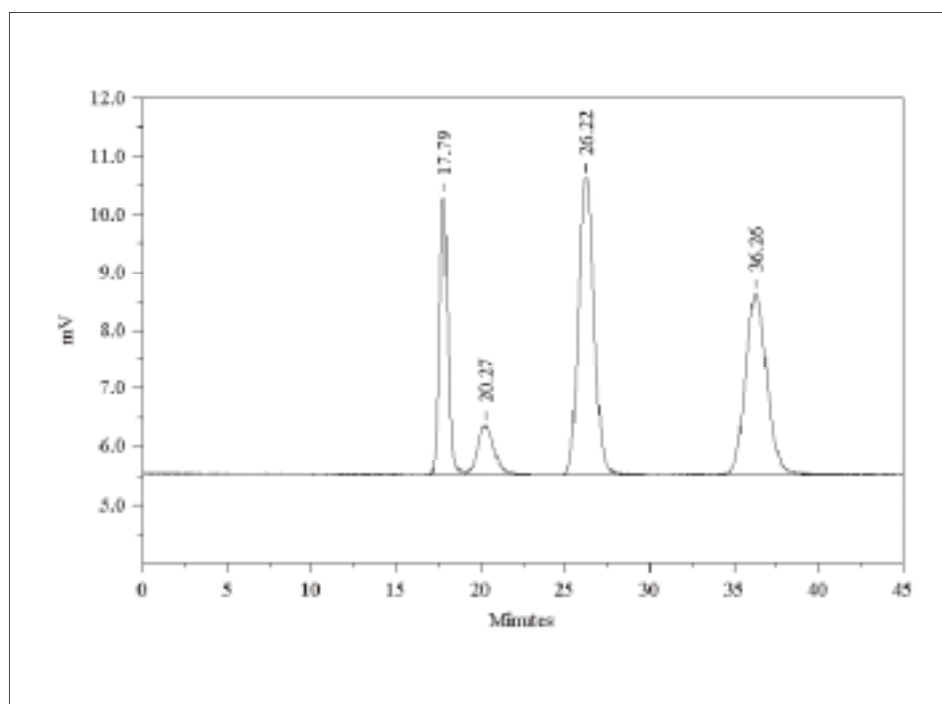

The peak capacity of comprehensive multidimensional techniques approaches the product of the individual peak capacities of the two separations¹. When calculating the peak capacity of the total system the unmodulated peak capacity of the 1st dimension is no longer a true reflection of the attained peak capacity after modulation. With the stop flow conditions used for flow modulation, the peak capacity of the SFC separation is equal to the peak capacity of the 'new' chromatogram that is obtained after the average of flow and no-flow conditions have been obtained. Figure 8-4 shows an unmodulated chromatogram of the SFC separation. The peak capacity of the unmodulated chromatogram is $n_c=12$. Figure

8-5 shows the modulated chromatogram. The peak capacity of this chromatogram is reduced to $n_c = 8$. This is probably due to the increased residence time of the sample in the column leading to more longitudinal diffusion (B-term) and thus an increased plate height. In this case, faster restrictors were used for the modulated chromatogram. This may also adversely affect the Van Deemter C-term. However, the faster flow rate for the modulated chromatogram reduced the run time to 100 minutes, while still allowing ample samples across the SFC peak.

Figure 8-5: Modulated SFC chromatogram.

5 second collection time. GC cycle time: 60 seconds.

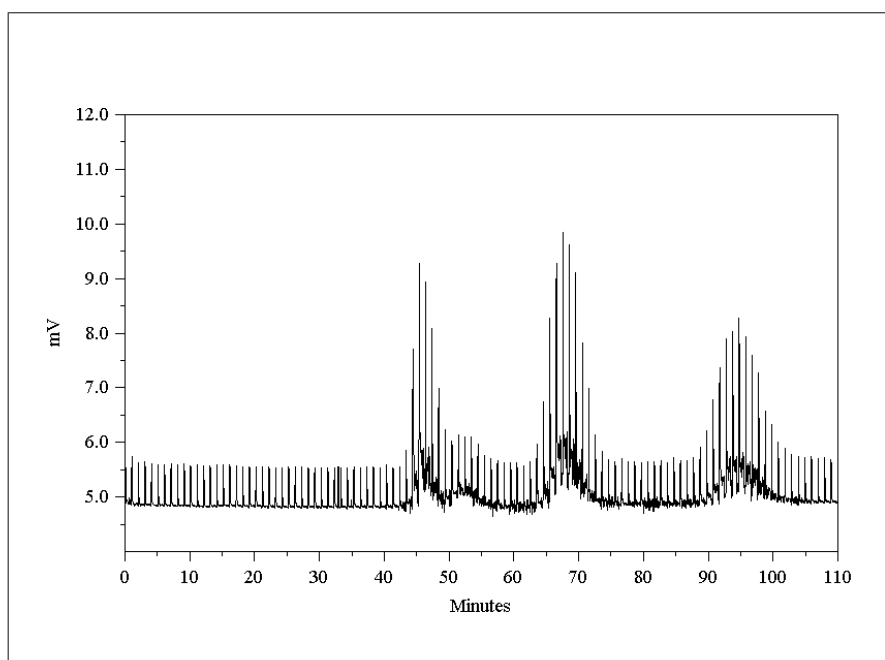

8.4.6 Modulation programming

In SFC, pressure programming is often used to solve *the general elution problem* in the same way as temperature programming does for GC. Sometimes this can not be done due to factors such as the mechanical strength of the column walls in capillary SFC or when pressure-programming facilities are not available. It should

in principle be possible to combat the general elution problem with *programmed modulation*, which would be equivalent to flow programming. Here the collection time is increased from cut to cut in proportion to the peak broadening. The number of cuts per peak can be kept constant at the 6 required to recreate the first dimension chromatogram from the GC data points. A programmed effect will be obtained in the resultant three-dimensional chromatogram leading to savings in SFCxGC_{ftp} analysis time and improved detection limits.

8.5 Conclusions

A modulator was constructed that uses stopped flow and pressure drop modulation to transfer cuts from the SFC to a fast temperature programmed GC for volatility analysis. The modulator also allows for the exchange of CO₂ with H₂ carrier gas for a more efficient high speed GC separation.

The modulator provides for easy and flexible interfacing between the two dimensions of the SFCxGC_{ftp}. It is robust, as it does not require the use of thermal zones or moving parts other than the valve internals at room temperature.

The Peak capacity of the SFC analysis is slightly decreased by stopped flow operation. A peak capacity of 8 was achieved after stop flow modulation with the packed column. Together with the peak capacity of 60 for the GC_{ftp} a total peak capacity for the of 500 can be projected for the SFCxGC_{ftp}.

However, more than 220 000 theoretical plates have been reported for SFC separations when 11 SFC columns were connected in series and used together with methanol modifier¹.

Thus, the peak capacity of SFCxGC_{ftp} could approach that of GCxGC.

Chapter 8

¹ T.A.Berger, W.H.Wilson, Anal.Chem. 65 (1993) p1451

Chapter 9

Demonstration of the comprehensive two-dimensional SFCxGC_{ftp}

9.1 Introduction

Comprehensive two-dimensional chromatography is a technique where two chromatographic separations are coupled together in such a way that the initial separation is maintained by subsequent steps. For the SFCxGC_{ftp} presented here, an initial polar analysis was performed on a silica gel column. A stopped flow and pressure drop focussing arrangement was used to transfer cuts from the SFC to a fast temperature programmed GC.

Two different types of silica gel columns were applied to group separation:

- The packed column silica gel separation of chemical classes with SFC is a well-known application¹. It is used to separate petrochemical liquids into aliphatic, aromatic and poly-aromatic compound classes. A packed silica column was used with the SFCxGC_{ftp} as the first dimension to analyze petrol and diesel samples.
- The use of a porous layer open tubular (PLOT) column for the group analysis of oxygenated compound classes was also demonstrated in Chapter 6. Here, the PLOT column will be used with SFCxGC_{ftp} for the separation of oxygenated compounds relevant to the petrochemical industry and to analyze a lemon essential oil.

Compounds in a chemical class have similar chemical functionality but differ widely in boiling point. In order to analyze each class for this boiling point distribution, temperature programmed GC is required. Each SFC peak has to be sampled many times to ensure that the peak information of the SFC separation is conserved. Thus, very fast second dimension separations are required. To this end, the fast resistive GC developed in Chapter 4 will be applied.

Transfer of each fraction between the SFC and GC was facilitated with a special interface called the stopped-flow-pressure-drop-focusing modulator. This interface periodically stops the flow in the SFC, providing time for the volatility analysis. Through this interface, CO₂ gas from the SFC exit was exchanged for hydrogen to facilitate a faster GC separation.

9.2 Experimental

9.2.1 The supercritical fluid chromatograph

As described in Chapter 6, a piston pump was used to deliver SFC grade CO₂ at 150 atm to a 2.1 mm x 250 mm column packed with silica gel. An electrically actuated internal loop injector with an internal volume of 0.2 μL was used for sample injection. The column was coupled through a low dead volume T-connector to two integral restrictors². One restrictor was connected to the detector and the other to the split/splitless injector on a Varian 3300 gas chromatograph.

9.2.2 The modulator

Flow modulation was achieved with an electrically actuated six-port valve with all but two adjacent ports closed off. Valve switching was controlled with a TTL pulse from a multipurpose input/output board. The valve was placed in between the splitter-restrictor assembly and the SFC column outlet. The eluent was transferred to the split/splitless injector on the Varian 3300 through one of the SFC restrictors. The injector splitter was opened and closed with a solenoid valve controlled from the PC by TTL pulse. A bypass switch was installed to allow the splitter valve to be opened and closed either from the computer or through the normal GC control panel.

The entire column was cooled down to the ramp starting temperature with CO₂, using the sub-ambient temperature control of the Varian 3300. External oven control was achieved through a small modification on the temperature control board of the GC. An override switch was installed to allow either the GC to operate normally or for the LabVIEW program to take command of the temperature control PCB that turns the oven, oven fan and cooling on or off.

After concentration of analytes on the column, a five second equilibration time was allowed for the pressure in the injector to normalize.

9.2.3 Resistively heated gas chromatograph

One meter of a 0.25 mm i.d. SE-30 stainless steel column (Restek Ultra alloy) was tightly coiled. The coil diameter was 1.5 cm. The column was connected to the split/splitless injector and FID detector on a Varian 3300. A 30V-power supply was connected to the heated column connectors on the injector and detector legs. Graphite ferrules ensured good electrical contact between the connectors and the metal column. The detector and injector legs were electrically isolated from the body of the GC. The current through the column was controlled from the computer by adjusting the base voltage on a power transistor. A very small thermocouple was constructed from type K thermocouple wire. The wires had diameters of 25 micrometer (Goodfellow, Cambridge GB). The thermocouple was glued to the column with a tiny spot of polyimide resin (Alldrich). The temperature was controlled through PID feedback on the thermocouple signal. A program written in LabVIEW (Version5.1.1) with the LabVIEW PID control kit was used for temperature control (See LabVIEW program 4.a). A flexible heater tape was coiled around the detector and injector legs to ensure that they reached the upper temperature of the ramp. The fast resistive GC is described in detail in Chapter 4.

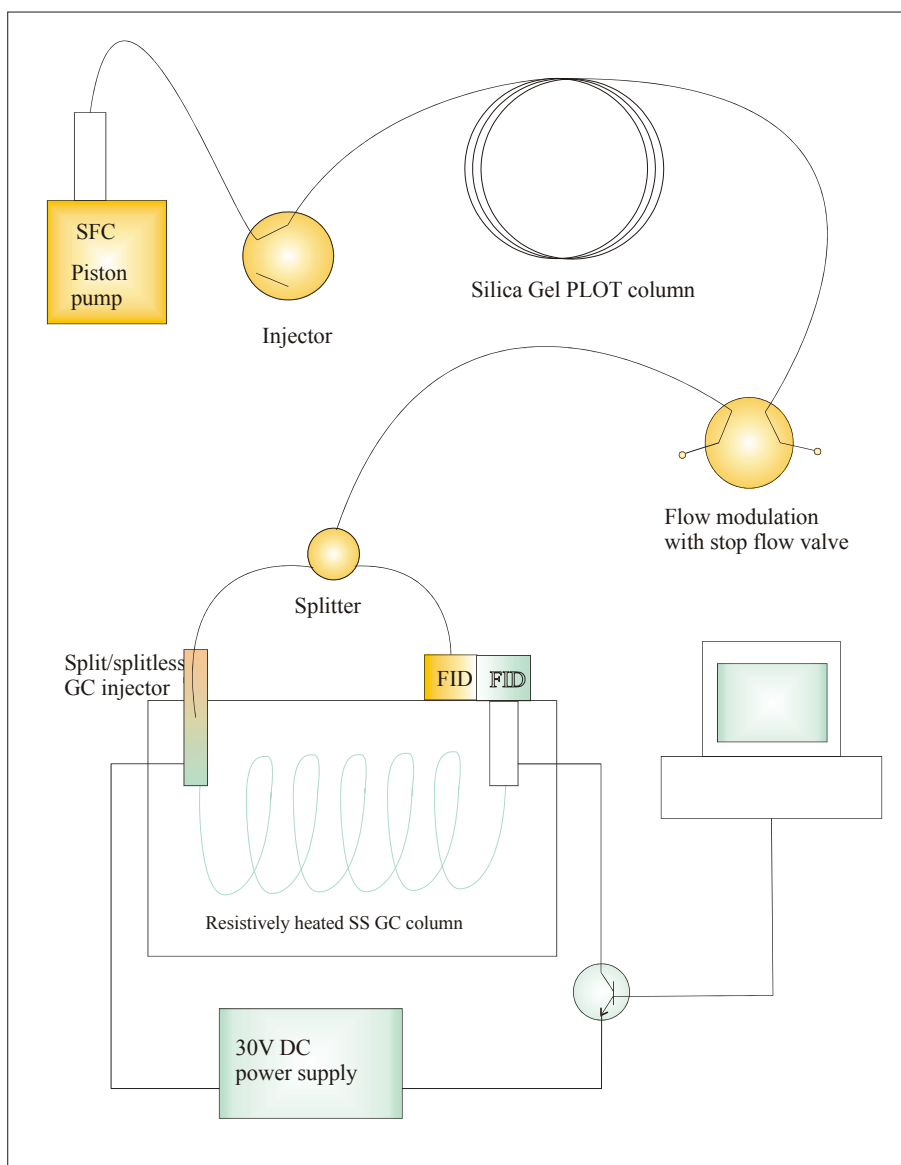
Figure 9-1: Schematic of Instrumentation used for SFCxGC_{ftp}

The first rudimental embodiment of the technology is depicted in the photograph shown in Figure 9-2. Three computers, two GC ovens, a power supply, electronics box, SFC pump and cooler take up a good 3m² of laboratory space. Further development will see the reduction in components to one computer, one GC oven and a SFC pump with built in peltier element for cooling.

Figure 9-2: Photograph of the comprehensive two-dimensional supercritical fluid gas chromatograph.



9.2.4 Description of the operation of the SFCxGC_{ftp}

9.2.4.1 Control before a run

- The legs of the FID and split/splitless injector inside the GC oven are heated above the maximum temperature of the GC ramp.
- The FID on the fast GC is connected to an external fast amplifier. As described in Chapter 4 this allows for the observation of the very narrow peaks eluting from the fast GC.
- With the SFC pump filled with CO₂, it is pressurized to the operating pressure while the stop flow valve is open. Typically, a pressure of 150 atm is used.
- The modulation program (LabVIEW program 9.a) senses the position of the injector valve. This allows the program to know when an injection occurred and automatically starts modulation and data acquisition with the Chromperfect software. The valve should be in the loading position (blue) before the SFCxGC software is run. (LabVIEW program 9a).
- The column cooling is turned on automatically when the SFCxGC program (LabVIEW program 9a) is started and the operator waits for the ramp starting temperature to be reached before injection.

9.2.4.2 Control during a run

- After the computer senses an injection, the data acquisition software starts collecting data from the FID that is connected directly to the SFC via the split (see Figure 6-1)
- The stop flow valve is opened for 5 seconds or any other user defined interval. This value, as described in Chapter 7, is determined by the SFC peak widths. While the stop valve is open for sample to be collected, the pressure inside the injector increases to about 20 psi.
- After the 5 seconds collection period the stop flow valve is closed, the split on the injector is opened and a 5 seconds equilibration period allows for pressure in the injector to return to the operating pressure (typically 4 psi) for fast GC operation. The oven fan and cooling is also turned off at the beginning of this period.
- At the same time as the GC temperature program starts, the Chromperfect software starts collecting data from the FID connected to the GC.
- The maximum temperature of the ramp is reached typically in about 30 seconds, where after the oven fan and cooling is turned on to facilitate rapid cooling of the GC column. This phase takes about 20 seconds.
- Cooling is continued until the starting temperature of the ramp is reached and this temperature is maintained while the next sample is collected.
- This process is repeated until the end of the SFC run. The number of cycles can be predetermined from an unmodulated SFC run. However the operator normally terminates the analysis after the last expected peaks are observed.
- A typical GC cycle time of 1 minute is realized.

9.2.4.3 Data collection and handling

- Each GC run is stored in a separate file. Data files generated by Chromperfect have the format <name.##r>. The numbers are automatically generated by Chromperfect and increased from 00r to 99r where after the filename is automatically changed to <name1.##r> All the GC runs of a specific SFCxGC_{ftp} analysis are stored together in the same directory.
- The data files collected by Chromperfect are converted to tab delimited text.

-
- These files are collated into a single text matrix. The collation program uses the file extension to arrange files in order in the matrix. This has the implication that only a hundred files can be collated at a time. (See LabVIEW program 5)
 - A hundred text files are collated in a matrix at a time and the matrixes are then combined in Matlab to provide the entire SFCxGC_{ftp} analysis as a single matrix.
 - Transform software are used to produce surface and interpolated images for presentation and analysis.

9.3 Results and Discussion

9.3.1 Chromatograms obtained with the packed column

9.3.1.1 Analysis of a standard mixture

Figure 9-3 shows the analysis of a standard mixture containing the n-alkanes between decane (C₁₀) and tetracosane (C₂₄), the mono-aromatic compounds benzene, toluene, and a mixture of the xylenes and the di-aromatic compounds naphthalene and methyl-naphthalene. Here the high degree of order obtained with a SFCxGC_{ftp} analysis can be seen.

To the left of the chromatogram the n-alkanes are found decreasing in volatility from top to bottom. The mono-aromatic compounds elute next and are separated according to boiling point to show the different members of this group. Finally the di-aromatic compounds elute from the SFC and are analyzed for volatility. Good separation is obtained between naphthalene and methyl-naphthalene with a difference of only one methyl group.

Over the range of compounds analyzed, very good orthogonality is observed. Compound classes are clearly separated. With this presentation different groups are arranged in straight vertical bands. The wavy appearance of the spheres is an unfortunate result of retention time irreproducibility of the fast GC.

Figure 9-3: SFCxGC_{ftp} of a Petrochemical standard using a silica gel packed column

SFC: Pressure =150 atm, Temperature= 28°C

Modulation: Collection time=5 seconds, Equilibration time=5 seconds

GC: -50 to 250°C at 450°C/min. Flow rate = 1m/sec H₂

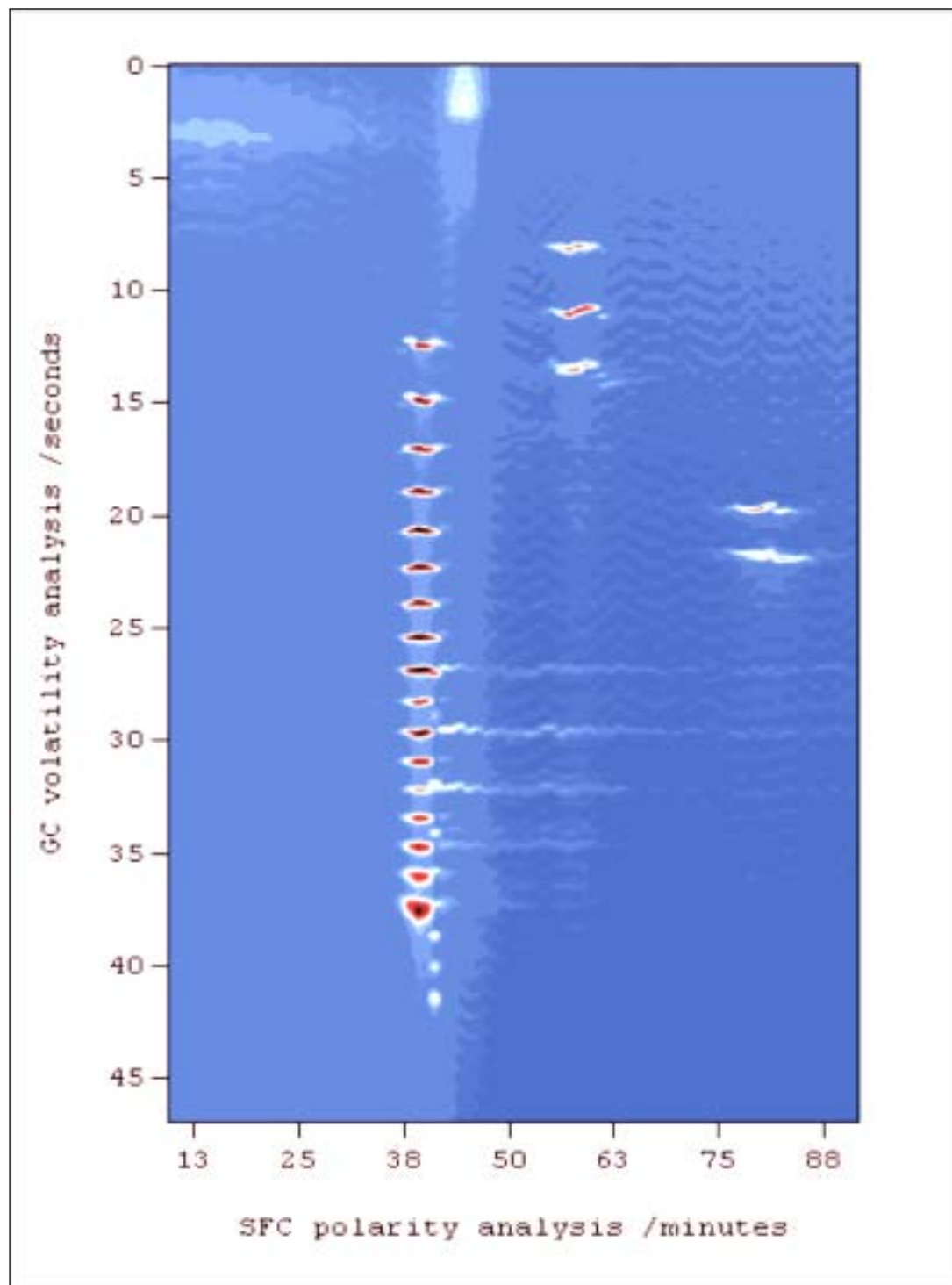
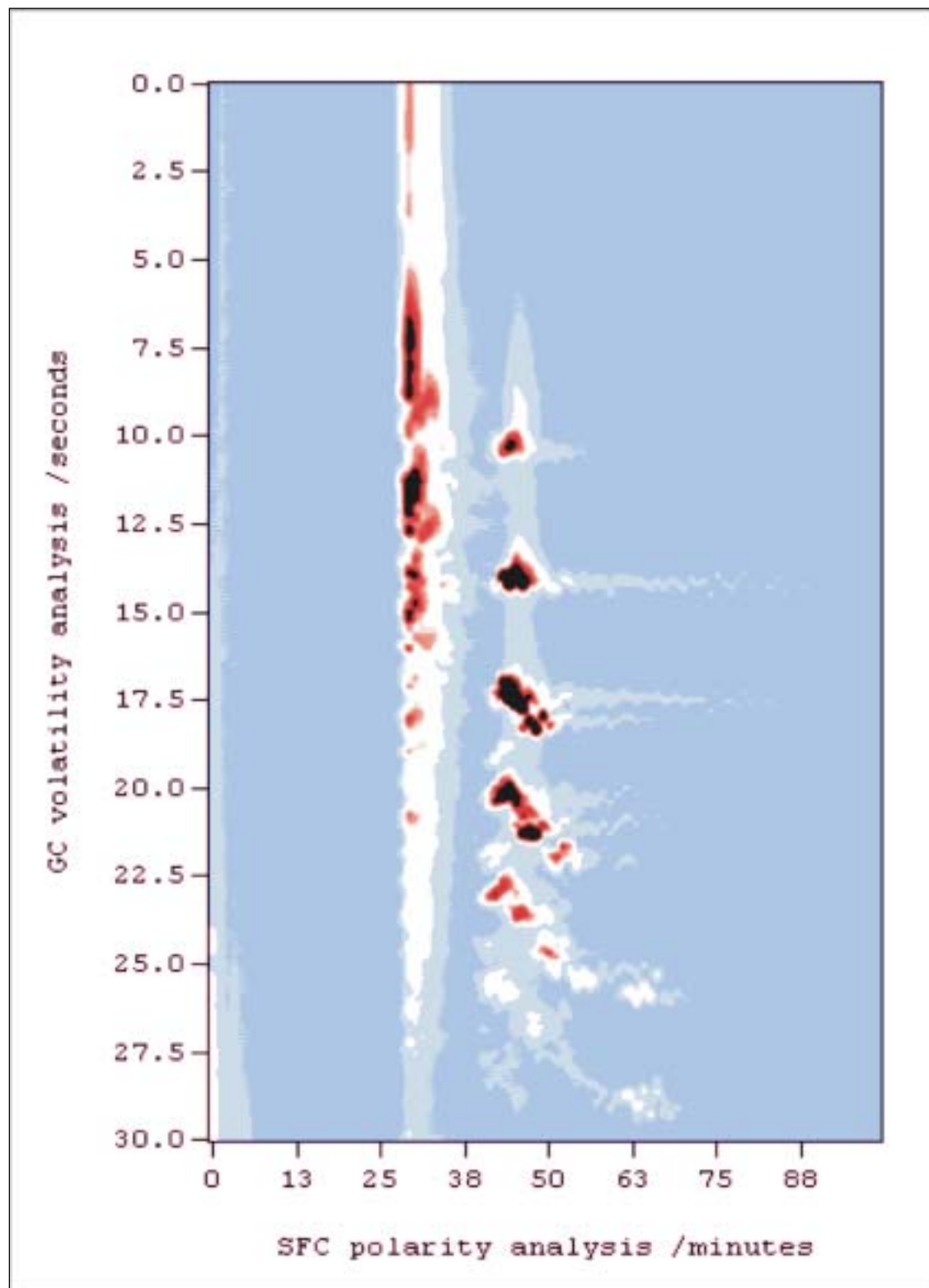

Figure 9-4: SFCxGC_{ftp} analysis of a petrol sample.

SFC: Pressure =150 atm, Temperature= 28°C

Modulation: Collection time=5 seconds, Equilibration time=5 seconds

GC: -50 to 250°C at 450°C/min. Flow rate = 1m/sec H₂



9.3.1.2 Analysis of a commercial petrol sample

The SFCxGC_{ftp} analysis of a petrol sample (Figure 9-4) correlates well with the chromatogram of the standard solution displayed in Figure 9-3. The aliphatic compounds on the left, decrease in volatility from the top to bottom. A set of spots that are not clearly separated from the alkane band is observed to the right of the alkane band. These spots probably belong to olefinic compounds. The mono-aromatic compounds are well resolved with respect to the increase in number of methyl groups present. Structural isomers form a diagonal band that indicates a second sample dimensionality present on the SFC column. The diagonal appearance of this band suggests correlation between the volatility and polarity axis for this sample dimensionality. No di-aromatic compounds were observed in this petrol sample.

The analyzed sample originated from the Fischer-Tropsch process. It is lead free petrol that contains a transition metal complex as anti-knocking agent and lubricant and is marketed by Sasol as 'Dual Fuel™'. The manufacturer claims that it can be used in all car engines, whether they are designed for lead-free petrol or not. The amount of aromatic compounds in this sample is quite high. Aromatic compounds tend to increase the octane level of unleaded petrol.

The same sample was analyzed with a commercial GCxGC instrument (Figure 9-5) that used a modulator with alternating pulses of hot and cold gas, as described in Chapter 7. Earlier compounds including benzene and toluene were not shown in this extraction of the GCxGC chromatogram, as they were not successfully trapped at the analysis temperature.

The effect of the slow ramp rate and long column length on the volatility axis was clearly beneficial. The result is a much larger peak capacity on the volatility axis. The high peak capacity on the first dimension also implies an increase in the number of cuts transferred to the second column. Because the transferred cuts are simple mixtures that typically contain less than ten compounds they can easily be separated in a short time with limited peak capacity. This is an advantage over SFCxGC_{ftp} where relatively complex mixtures are transferred to the second column for a fast analysis. As the number of chemical classes is limited and the group selectivity of the SFC separation is very high, the SFC can generate only a few peaks. Compounds can be spread out over the first axis by reducing this selectivity. However in this process correlation

between the two axes is increased. While more of the available separation space will be used, less separation space will be available due to the effect of correlation (See Figure 2-1).

Figure 9-5: GCxGC analysis of a petrol sample

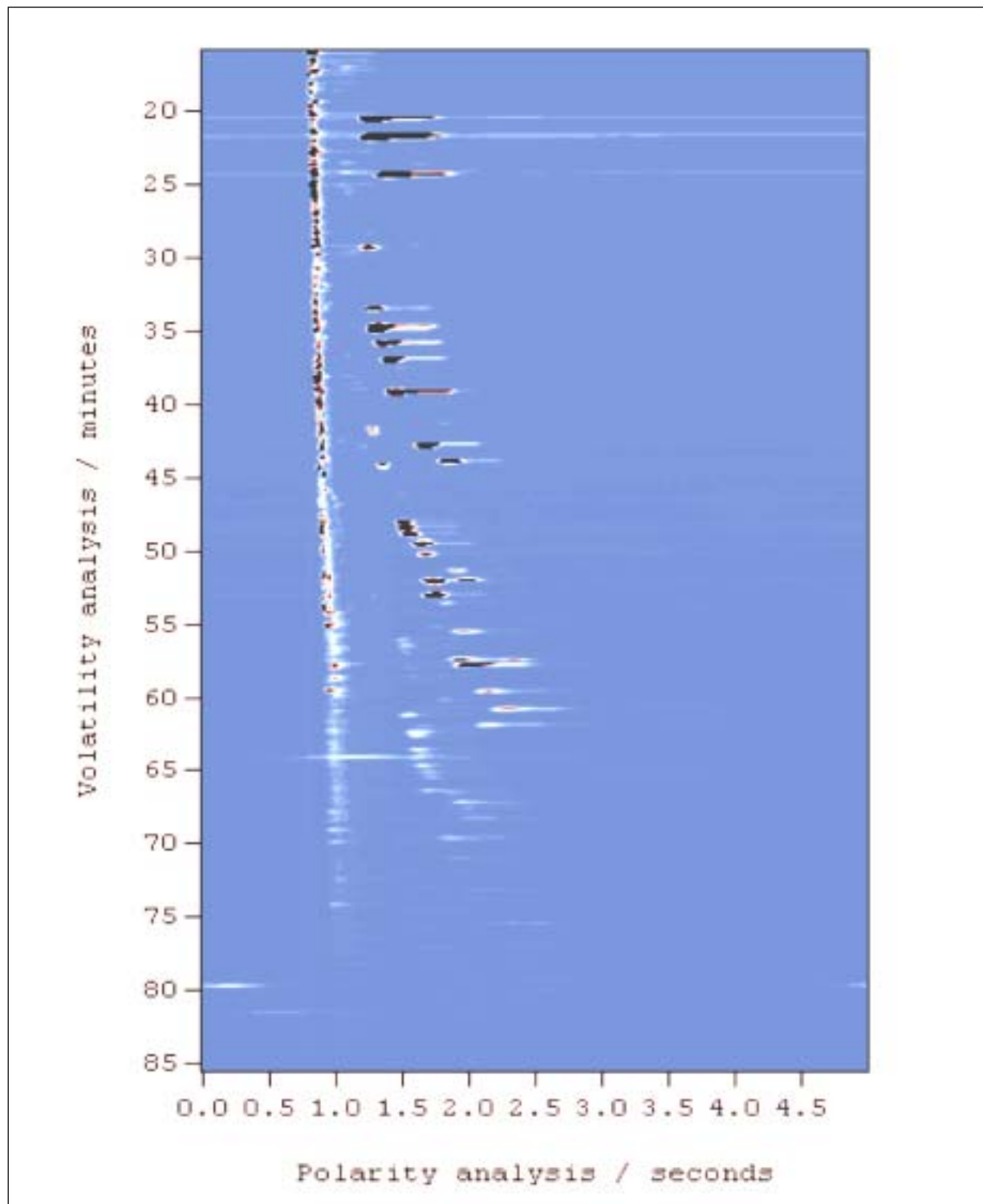

In more complex samples, where much functionality may be present on a single compound, group boundaries will be less clearly defined and more of the available separation space may be utilized.

The overall run time for the GCxGC and SFCxGC_{ftp} analyses are more or less the same, however, the GCxGC produces a much higher peak capacity per unit time. For the SFCxGC_{ftp} with hydrogen used as carrier gas and the ramp rate optimized to give the highest possible peak capacity per unit time, the only way to increase peak capacity and keep the GC analysis time short is by decreasing the diameter of the capillary column. However, this was not possible with the current instrumentation, as smaller diameter stainless steel columns are not currently commercially available.

The polarity of the GCxGC column used for the polarity separation in this experiment was not high enough to separate the olefinic compounds from the bulk aliphatic group. This higher selectivity of SFC for polar compounds is an obvious advantage over GCxGC, especially for compounds of high molecular weight since selectivity that entails polar or chiral interactions tends to decrease at higher temperatures.

9.3.1.3 Analysis of a diesel sample

In Figure 9-6 the n-alkane peaks are clearly visible with a smaller grouping of compounds in between each alkane peak. The mono-aromatics were well separated from the aliphatic group. For the less substituted mono-aromatics, individual compounds could be observed. Due to the multitude of possible structural isomers and the limited available separation space, the highly substituted mono-aromatic compounds were not resolved. However, a good visual impression of the volatility distribution of a sample can easily be noted. Low levels of di- and tri aromatic compounds were also observed in this sample. Structural isomers were again arranged in diagonal bands. These bands were also observed in the GCxGC analysis of similar samples (See Figure 9-7).

Figure 9-6: Analysis of a diesel sample with SFCxGC_{ftp}**SFC:** Pressure =150 atm, Temperature= 28°C**Modulation:** Collection time=5 seconds, Equilibration time=5 seconds**GC:** -50 to 300°C at 450°C/min. Flow rate = 1m/sec H₂

Figure 9-7: Analysis of a diesel sample with GCxGC



This figure demonstrates the immense peak capacity that can be produced with GCxGC instrumentation. However a more distinct separation is obtained between the aliphatic and aromatic compounds in SFCxGC_{ftp} than for GCxGC. This is due to the very high selectivity that can be obtained with the low temperature group separation realizable with the SFC separation.

9.3.2 Chromatograms obtained with the PLOT column

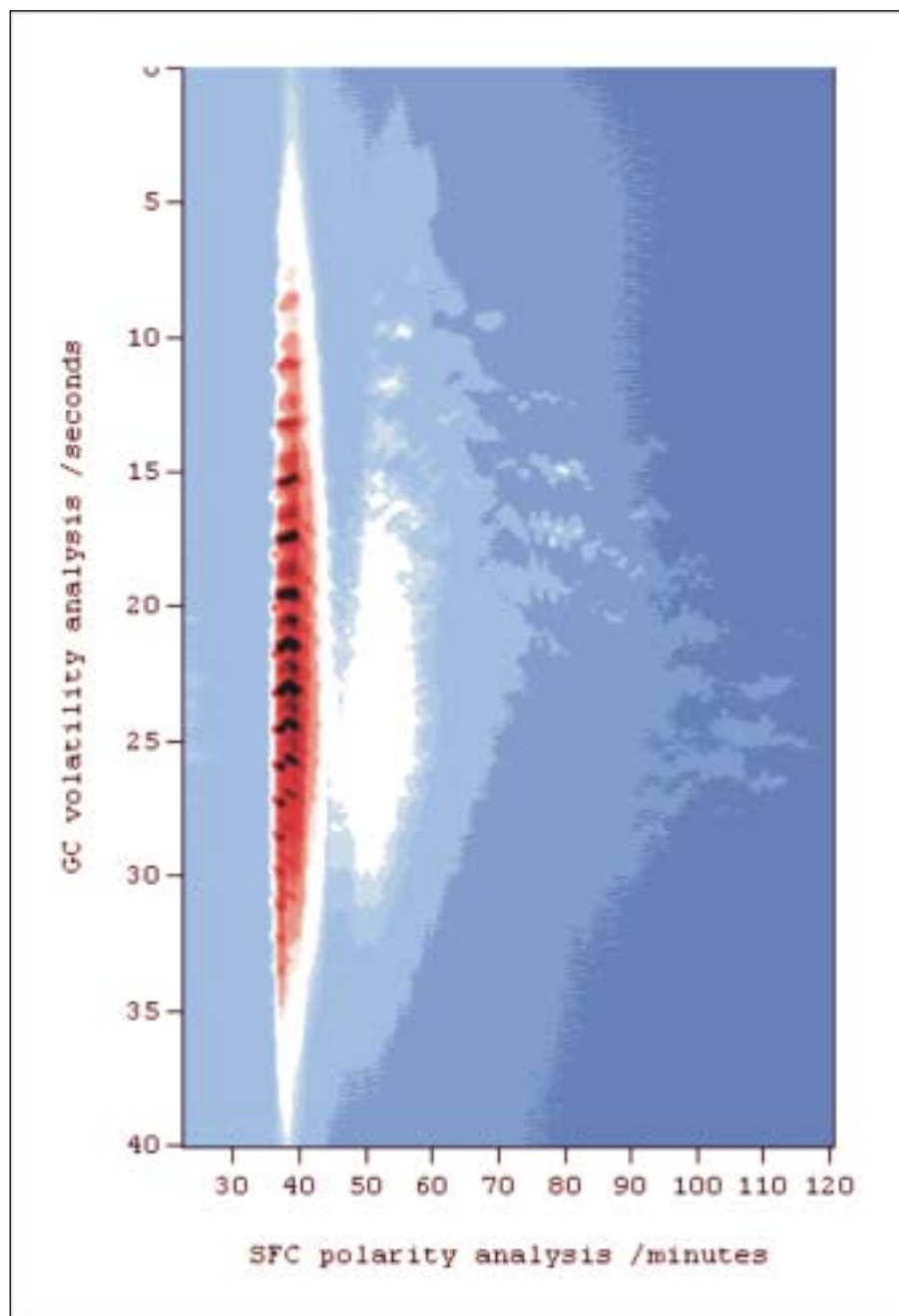
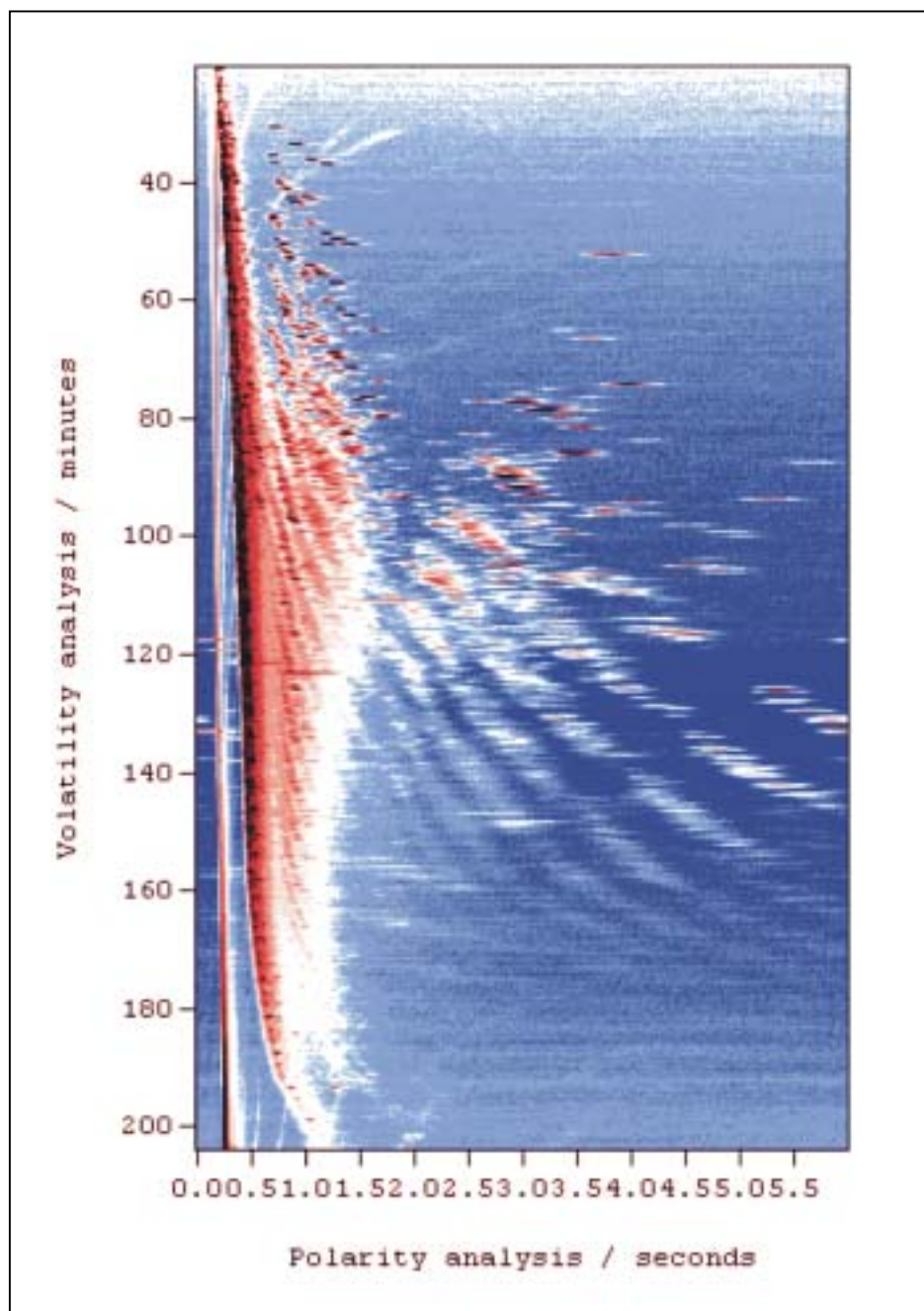
The packed column was exchanged with a silica gel porous layer open tubular (PLOT) column. This allowed highly polar compound classes to elute as separated groups. The column facilitated the analysis of oxygenates in petroleum samples and the analysis of essential oils by SFC_{PLOT}xGC_{ftp}.

9.3.2.1 Analysis of a standard mixture of oxygenates

The SFC analysis of the oxygenated petrochemical standard described in Chapter 6 shows the useful separation that can be obtained by the PLOT column alone. Such a separation is not easily obtainable with other instrumentation. Even GCxGC³ was unsuccessful. While GCxGC could separate alcohols, co-elution occurred between non-polar compounds and many of the important ethers, like DIPE, TAME and ETBE. When a similar standard is analyzed with SFC_{PLOT}xGC_{ftp}, the separation power of the technique becomes evident: TAME, MTBE and iso-propylether are well separated. The methyl and symmetrical ethers are divided into two separate groups. The volatility analysis of the second dimension separates these two groups further into their individual compounds. While ETBE was not available for testing the strong polar selectivity and the difference in volatility should also ensure good separation between ETBE and the other ethers.

The effective polarity of longer alcohols is reduced due to the effect of the long aliphatic chain. Thus, it is observed that dodecanol elutes slightly earlier from the SFC column than do the shorter alcohols like ethanol. This 'molecular weight' effect causes correlation between the two separation dimensions of polarity and volatility.

Figure 9-8: SFC_{PLOT}xGC_{ftp} analysis of an petrochemical standard containing alkanes, ethers and alcohols.

SFC: Pressure =150 atm, Temperature= 28°C

Modulation: Collection time=5 seconds, Equilibration time=5 seconds

GC: -50 to 250°C at 450°C/min. Flow rate = 1m/sec H₂

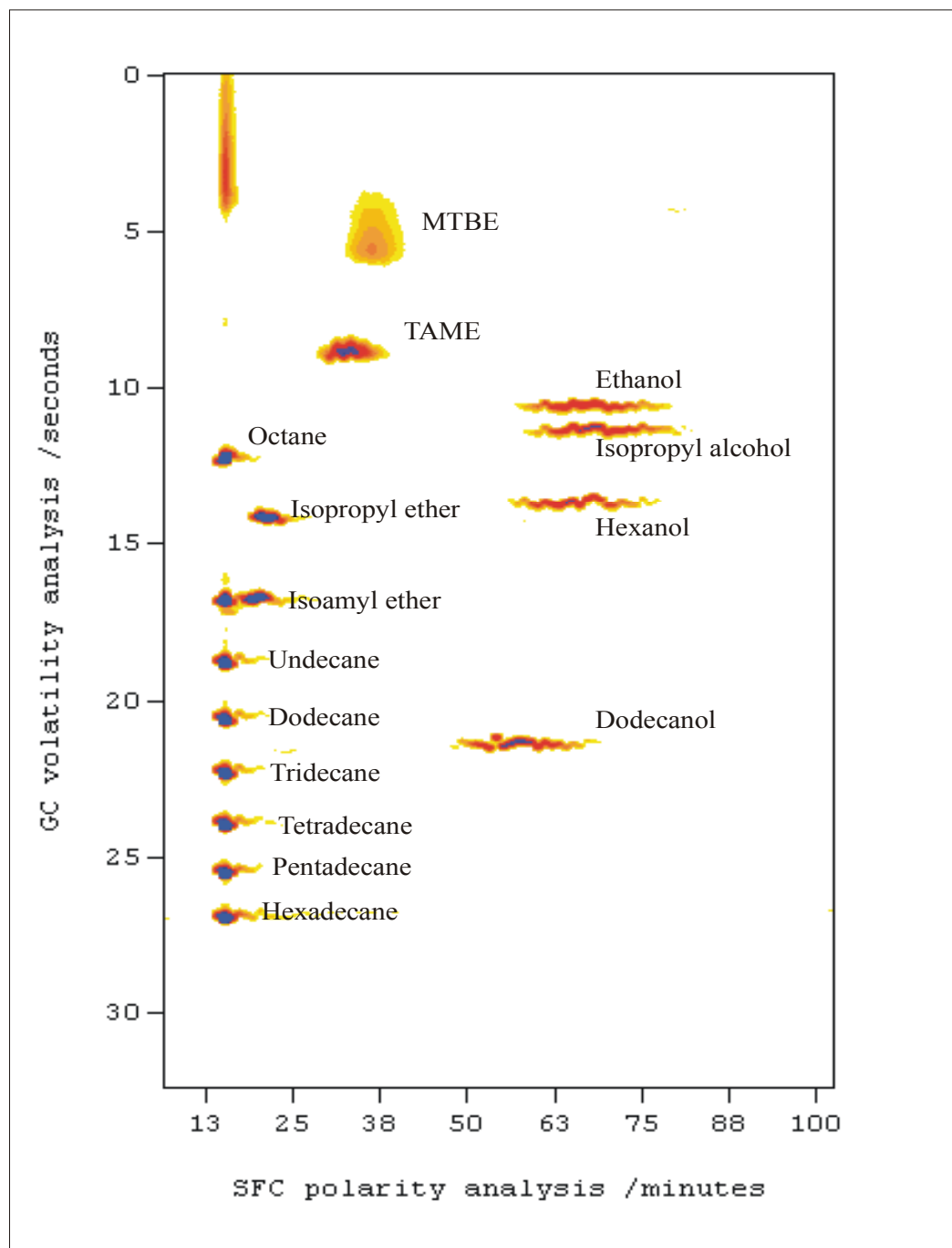
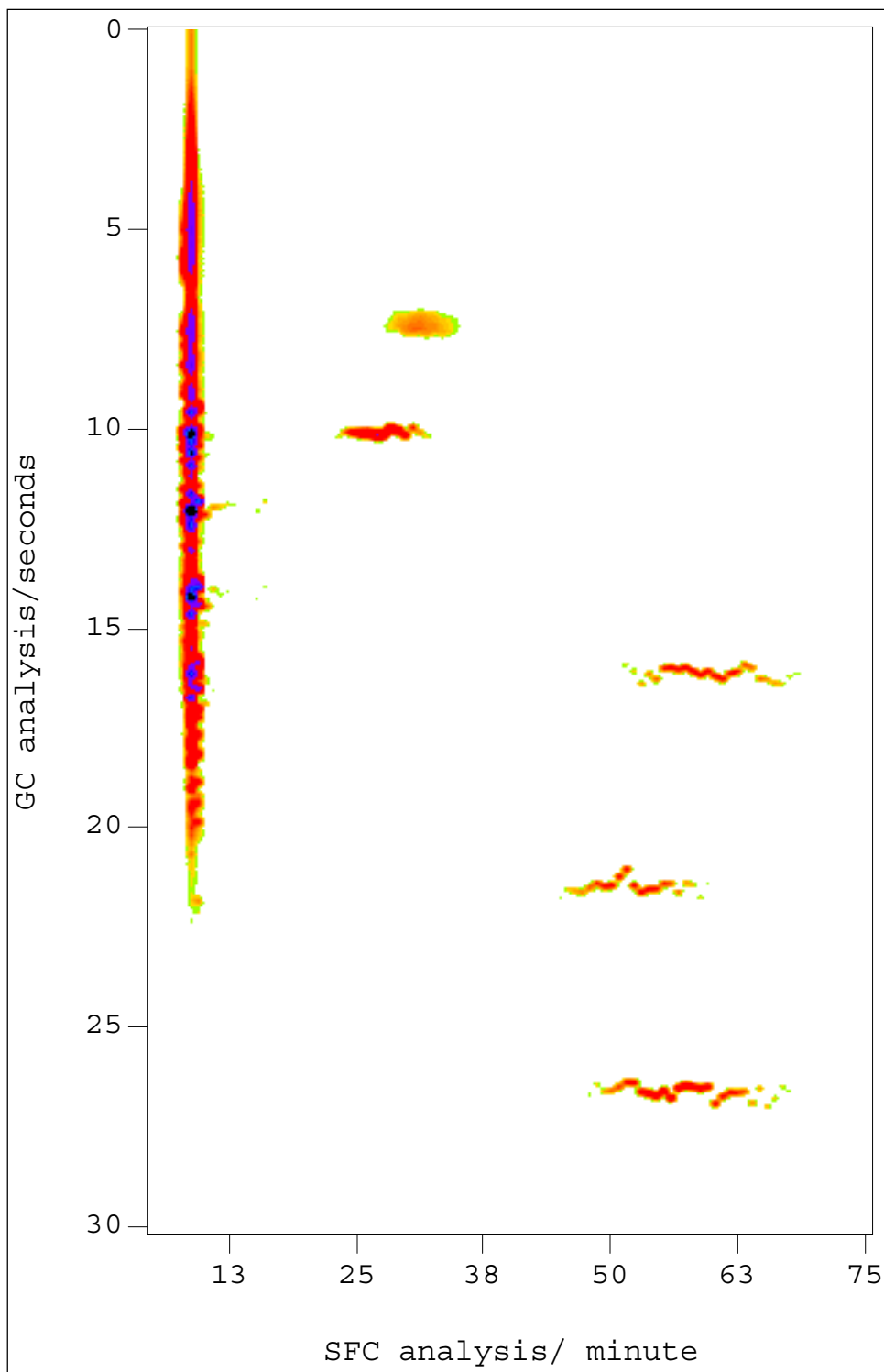

Figure 9-9: SFC_{PLOT}xGC_{ftp} analysis of a commercial lead free petrol sample spiked with ethers and alcohols.

SFC: Pressure =150 atm, Temperature= 28°C

Modulation: Collection time=5 seconds, Equilibration time=5 seconds

GC: -50 to 250°C at 450°C/min. Flow rate = 1m/sec H₂



9.3.2.2 Analysis of an unleaded petrol sample

The oxygenated standards added to the sample were all clearly separated from the non-polar aliphatic and the aromatic sample components. The standards added were isopropyl ether (IPE), t-amyl methyl ether (TAME), methyl t-butyl ether (MTBE) and iso-propanol, heptanol and dodecanol.

The petrol sample was also analyzed on its own without any oxygenates added. This is presented in Figure 9-10. The presence of a methyl ether, probably TAME by volatility axis displacement, is confirmed for the unleaded petrol sample with this chromatogram.

9.3.2.3 Analysis of a diesel sample (Natref LCO)

The Natref LCO sample analyzed by packed column SFC showed no clear distinction between the different groups. It was also noted that the sample contained some oxygenated compounds recovered through back-flushing of the column. With SFC_{PLOT}xGC_{ftp} analysis (Figure 9-11) it can be seen that, especially at high volatilities, the non-polar peak is smeared towards increased polarity. This could be the result of high molecular weight poly-aromatic hydrocarbons as anthracene was just separated from an alkane in Figure 6-3, or possibly from high molecular weight ethers with two long side chains.

A range of compounds is also seen to elute with retention times that correspond to the retention of methyl ethers at ≈ 17 minutes on the polarity axis. These would be the compounds responsible for the peak on backflushing of the column in the previous packed column SFC analysis (Table 6-1).

Figure 9-10: SFC_{PLOT}xGC_{ftp} analysis of a commercial lead free petrol sample.

SFC: Pressure =150 atm, Temperature= 28°C

Modulation: Collection time=5 seconds, Equilibration time=5 seconds

GC: -50 to 250°C at 450°C/min. Flow rate = 1m/sec H₂

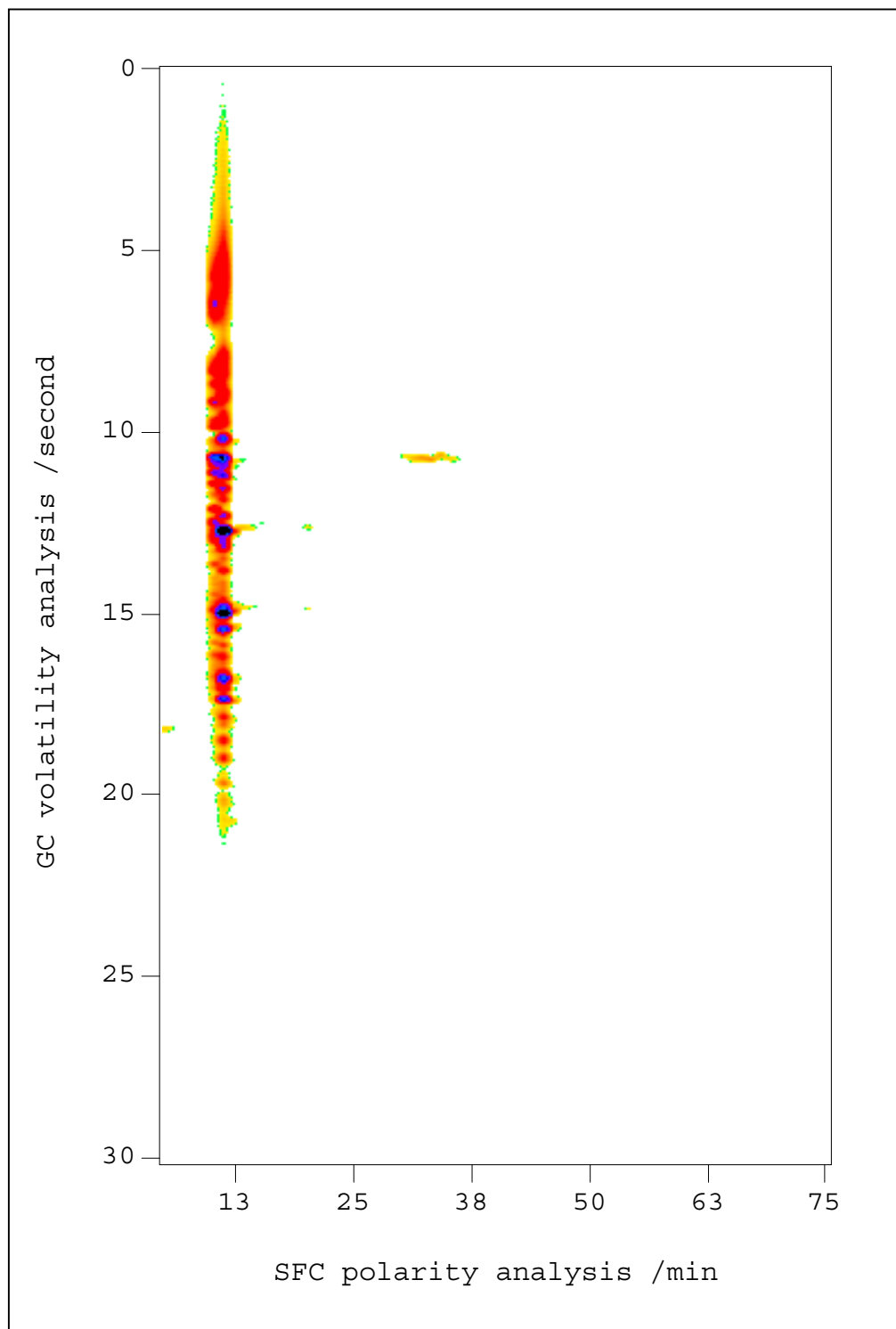

Figure 9-11 SFC_{PLOT}xGC_{ftp} analysis of the Natref LCO diesel sample analyzed with packed column SFC in Chapter 6.

SFC: Pressure =150 atm, Temperature= 28°C

Modulation: Collection time=5 seconds, Equilibration time=5 seconds

GC: -50 to 250°C at 450°C/min. Flow rate = 1m/sec H₂

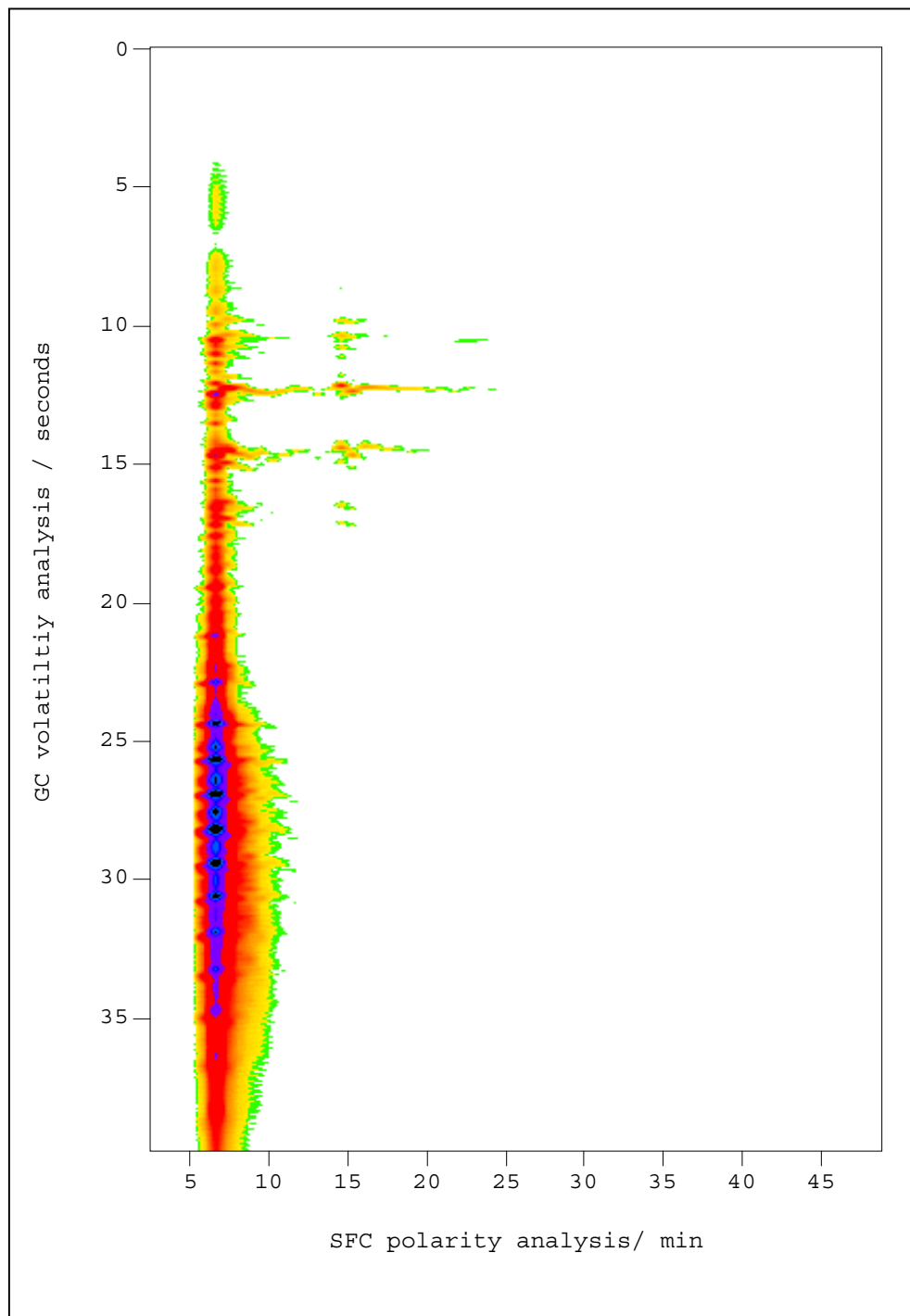
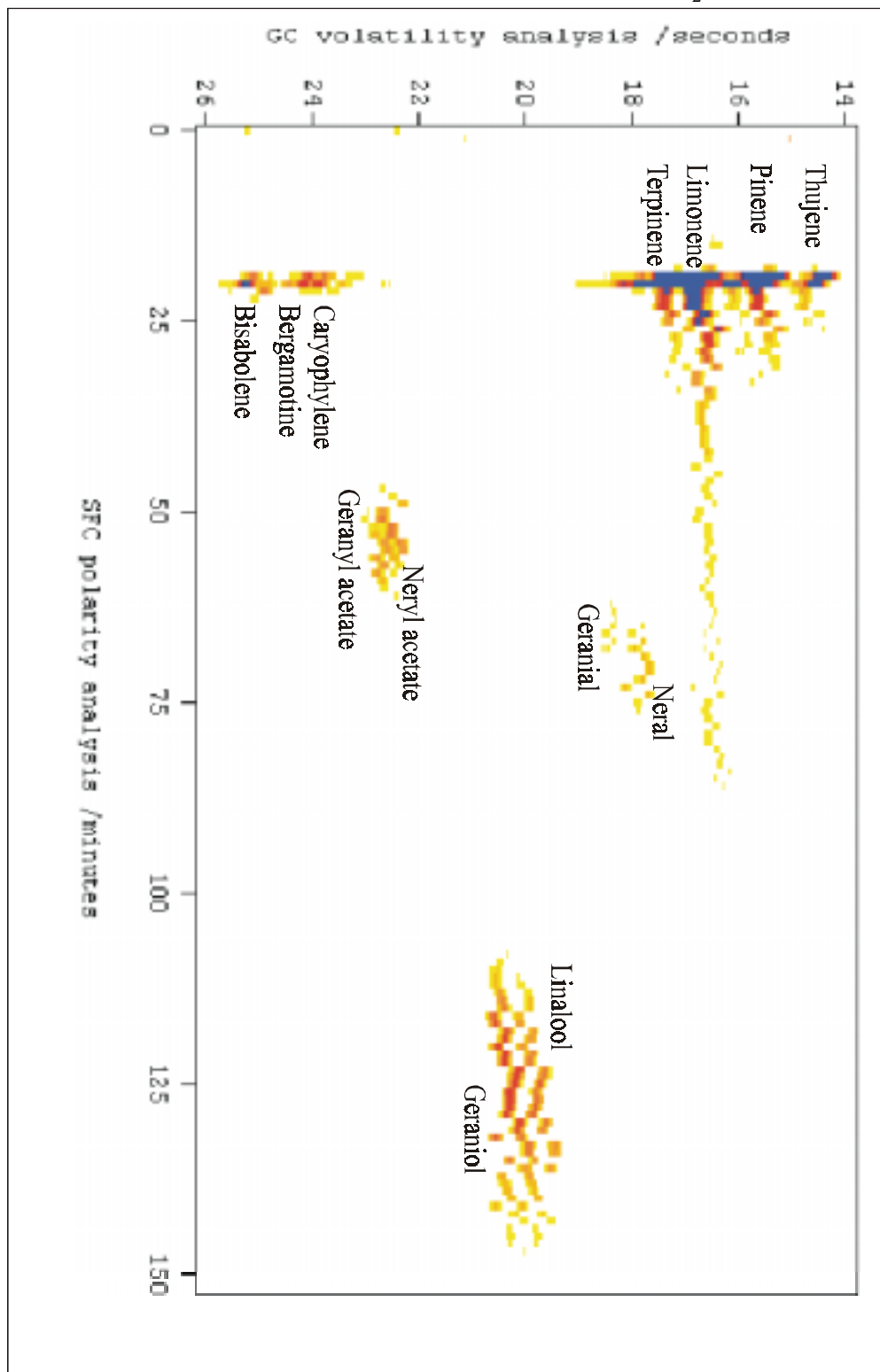

Figure 9-12: SFC_{PLOT}xGC_{ftp} analysis of a lemon essential oil.**SFC:** Pressure =110 to150 atm at 1 atm/min, Temperature= 28°C**Modulation:** Collection time=5 seconds, Equilibration time=5 seconds**GC:** -50 to 250°C at 450°C/min. Flow rate = 1m/sec H₂

9.3.2.4 Analysis of a lemon essential oil

The volatility axis greatly improves the group analysis of commercial lemon oil. When the PLOT column alone was used, groups could be identified but no baseline group resolution was obtained. Apart from improved group separation by the combination SFC_{PLOT}xGC_{ftp}, additional groups could also be identified. A clear distinction between mono- and sesquiterpenes was observed. While there is a large volatility gap between the mono terpenes(C₁₀ compounds) and sesquiterpenes (C₁₅-compounds) the distinction is not normally so obvious in GC analysis because the oxygenated compounds are of intermediate volatility. Apart from improved group separation, the constituents of each group are also separated according to volatility. Thus, for the alcohol group, linalool and geraniol are seen to be present at a high level. Citral and geranial are separated, as is citral acetate and geranyl acetate. For the terpene group, however, the peak capacity of the boiling point separation is not high enough to clearly separate every compound. This is especially a problem for the mono-terpenes. Having both the group separation and boiling point distribution available on one chromatogram greatly simplifies compound identification.

9.4 Conclusions

The chromatograms obtained with SFCxGC_{ftp} strongly resemble the results obtained with GCxGC. A high degree of order is obtained. Due to the high polar selectivity by the low temperature SFC separation, a more orthogonal separation space is obtained.

Unfortunately, the peak capacity of the volatility dimension is much less for SFCxGC_{ftp} than for GCxGC. This is due to the order of separation. For GCxGC the more complex volatility chromatogram is the slower, first dimension. This same separation (though slightly simplified by the preceding group separation) needs to be achieved in a very short time with SFCxGC_{ftp}. Apart from the lower peak capacity other practical problems like retention time irreproducibility were encountered.

Operation of the modulator that turns the SFC and GC into a comprehensive chromatograph is simple relative to the thermal and cryogenic modulators. It allows independent optimization of the two separation dimensions. This simplifies method development, as a change in one dimension does not alter the operation of the other e.g. no changes to the GC separation were needed when exchanging the packed column for the PLOT.

The first results obtained with the comprehensive SFCxGC_{ftp} are very promising. This technique is sure to find its rightful place among the comprehensive chromatographic techniques. The potential to analyze a wide boiling point range of samples, the mild conditions compounds are subjected to, as well as the high selectivity of the low temperature first separation, are bound to give SFCxGC_{ftp} an advantage over other available analysis techniques.

Chapter 9

¹ Annual Book of ASTM standards, Vol 05.03. American society for testing and materials, Philadelphia (1991) Method ASTM D5186

² E.J.Guthrie, H.E.Swartz, J.Chrom.Sci. 24 (1986) p236

³ G.S.Frysinger, R.B.Gaines, HRC 23 (2000) p197

Chapter 10

Conclusions

A comprehensive two-dimensional supercritical fluid and fast temperature programmed gas chromatograph has been constructed. The chromatograms produced by the SFCxGC_{ftp} are comparable to that produced by GCxGC. However, less peak capacity can be produced than with GCxGC. On the other hand, more orthogonal separations are possible with SFCxGC_{ftp} because of the stronger group selectivity provided by SFC on silica gel.

In order to design and construct the SFCxGC_{ftp}, a fast resistive temperature programmed GC was developed. Further, group separation by SFC on silica gel was extended to include the class analysis of highly polar groups.

10.1 Group separation with SFC as a first separation dimension

It was demonstrated that the retention of highly polar compounds on silica gel columns could be much reduced by increasing the phase ratio (β -factor) of the column. Even alcohols and organic acids could be eluted from a silica gel PLOT column. Compounds of the same chemical class eluted together in a group and the co-elution between oxygenated and non-polar molecules were precluded. A competitive method for the analysis of oxygenates in petrochemical samples are provided when compared to other known procedures^{1,2}.

In supercritical fluids, the optimum flow rate (for maximum resolution) brings about very long retention times on account of slow mass transfer. However, because of excess resolution, flow

¹ *Annual Book of ASTM standards*, ASTM D4815-94a Volume 05.02 (1997)

² *Annual Book of ASTM standards*, ASTM D5599-95 Volume 05.02 (1997)

rates much above the optimum provided adequate separation of all groups in acceptable analysis times. This was true even for samples with wide boiling point ranges.

10.2 Fast resistive heating for boiling point distribution in SFCxGC_{ftp}

Various temperature measurement circuits were built and considered for use in fast gas chromatography. These generally operated reasonably well when no heating current was applied. However, when simultaneous heating and measurement was attempted many problems were encountered. The use of a micro thermocouple was successful for the measurement of temperatures during column heating. Micro-thermocouples were manufactured in-house and glued to the column using polyimide resin. Thermocouples provided reproducible results within a thermocouple placement. Unfortunately, thermocouples were found to be fragile and required frequent replacement. Different thermocouple placements influenced the thermocouple readings. Retention times of low boiling compounds compared well with those obtained from a conventional heated GC. However, at higher temperatures compounds tended to elute earlier on the resistive GC. This was due to the distance between the thermocouple and the column caused by the insulating glue.

The temperature programming rate was optimized to provide the highest peak capacity in the shortest time. This was obtained by maintaining a normalized ramp rate of 10°C/tm and changing flow rates and actual ramp rates. The highest peak capacity was obtained at a ramp rate of 450°C/min with a flow rate of 100 cm/sec. Under these conditions the 1 meter column delivered a peak capacity of n=60 in less than 30 seconds.

The influence of CO₂ as potential mobile phase for fast resistive GC was investigated. This was relevant due to the large amount of CO₂ gas produced when the SFC mobile decompresses at the restrictor. While the loss in efficiency can be recovered by decreasing the column diameter, best results will be obtained when H₂ together with a column with a small inner diameter is used.

10.3 The stopped flow pressure drop modulation interface

A novel interface was created to accomplish the comprehensive combination of SFC and temperature programmed GC. This interface uses stopped flow chromatography in the SFC separation axis. Stopped flow modulation caused a mild loss in peak capacity of the polar separation. However, adequate resolution between the studied groups was still obtained. Compounds eluting from the SFC were focussed in the interface due to loss of solvation when the supercritical mobile phase decompresses at the restrictor exit. This was augmented by the low starting temperature of the GC. The interface also allows for the exchange of carrier gas, providing the optimum separation speed during the GC separation. This interface is the subject of a provisional patent³.

10.4 Advantages to SFCxGC_{ftp}

There are numerous advantages to the technique relative to other multidimensional techniques. These are due to a low temperature 1st dimension, together with independent fast temperature programming in the 2nd dimension, exchange of the chemical composition of the mobile phase and de-coupling of the operating conditions of the two dimensions by connection through stop-flow modulation. Briefly the advantages are:

- A. Independent fast temperature programming in the 2nd dimension with a low temperature 1st dimension provides:**
1. Less correlation between the separation mechanisms of the 1st and 2nd dimensions. The two dimensions of the new SFCxGC apparatus is thus said to be potentially more orthogonal than GCxGC or existing SFCxGC instrumentation.
 2. Low temperature operation of the SFC dimension increases selectivity to chemical differences in sample components such as polarity, chirality or molecular shape, given a suitable stationary phase.
 3. Less critical injection times into the second 2nd dimension than for GCxGC or existing SFCxGC instrumentation. Temperature modulation in the SFCxGC interface is not

³ A.Venter, E.R.Rohwer, Chemical method of analysis, Patent number: SA2002/202

Assignee: University of Pretoria, March 2002,

required due to the focussing effect on the low temperature of the 2nd dimension column.

4. Efficient separation of volatile organic modifiers from analytes allowing the use of FID and Mass Spectrometric detection, despite the presence of modifiers in the 1st dimension mobile phase.
5. With this invention only the polydimethylsiloxane stationary phases, that can withstand high temperatures, are heated. The polar analysis is achieved at room temperature and does not rely on using polar phases such as the thermo labile polyethyleneglycol at elevated temperatures. This implies that samples with higher final boiling points can be analysed than with GCxGC instrumentation.
6. Thermally labile compounds are at high temperatures for a much shorter time and are therefore less likely to decompose than with GCxGC or existing SFCxGC instrumentation where both columns are operated at high oven temperatures for a prolonged time. This comprehensive combination of SFC and GC thus expands the scope of compounds to be analysed to include less stable ones.

B. Stop-Flow modulation

1. Provides flexibility in the operational parameters of each dimension allowing these to be optimised independently
2. A slower 2nd dimension allows easier interfacing with conventional Mass Spectrometry than GCxGC or existing SFCxGC instrumentation. GC peak widths are typically 40 to 500 ms wide.
3. Eliminates the need for complex thermal modulation of the interface.

C. Change in mobile phase composition

1. Allows the use of 1st dimension mobile phase that is incompatible with, or interferes strongly with detection in the 2nd dimension. Organic mobile phases or CO₂ with organic modifiers can be used with FID or MS detection.
2. Allows higher speed 2nd dimension separations thus improving total analysis time by reducing the 2nd dimension cycle time. This cycle is repeated many times during an analysis and thus contributes additively to the total run time.
3. Faster 2nd dimension analysis further implies that the 1st dimension can be run faster while still transferring ample cuts to the 2nd dimension. This helps to preserve the

resolution already obtained in the 1st dimension and the analysis to be completed in a shorter time. Peak capacity production per unit time is thus improved.

10.5 SFCxGC_{ftp} Applications

Two established ASTM methods could easily be combined with SFCxGC_{ftp}. The ASTM method ASTM D5186 for petrochemical group separation and ASTM D3710 for simulated distillation of gasoline samples together will provide ample information for petrochemical plant optimization or blending operations.

Because of the high degree of order attained with SFCxGC_{ftp}, the two-dimensional chromatograms may be very useful when combined with neural networks. These could be used for process control, to detect adulteration, or to identify the origin of a pollution incident.

This instrument will also be a valuable tool for the analysis of plant extracts, as was demonstrated for a lemon essential oil. Compound identification is eased for unknown mixtures by the independent presentation of sample dimensionalities.

The first results obtained with the comprehensive SFCxGC_{ftp} are very promising. This technique is sure to find its rightful place among the comprehensive chromatographic techniques. The potential to analyze a wide boiling point range of samples, the mild conditions compounds are subjected to, as well as the high selectivity of the low temperature first separation are bound to give SFCxGC_{ftp} an advantage over other available analysis techniques for some applications.

CURRICULUM VITAE**ANDRÉ VENTER**

Work Address Scientific Development and Integration (Pty) Ltd
 CSIR campus
 Meiring Naude Road, Pretoria

 PO box 1559
 Pretoria
 0001

Postal Address PO Box 35226
 Menlo Park
 0102

Telephone Numbers (012) 349 2122 (work)
 083 291 7263 (cell)

Email address andre.venter@sdi.co.za

PERSONAL DATA

Name André Venter

Identity Number 721030 5158 089

Date of Birth 30 October 1972

Sex Male

Marital Status Single

Driver's Licence 08/91-04-18

Nationality South African

Home Language Afrikaans

Other Languages English (fluent: speak, read and write)

Health Excellent

SECONDARY EDUCATION

Last School Attended	Hoërskool Verwoerdburg (1986-1990)
Highest Standard Passed	Matric (B aggregate)
Subject Passed in Higher Grade	English, Afrikaans, Mathematics, Science, Biology, Geography

TERTIARY EDUCATION

University	University of Pretoria
Degrees	B.Sc. (Chemistry and Industrial Chemistry) – 1994 B.Sc. Honours (Chemistry) – 1995 M.Sc. (Chemistry), <i>Cum Laude</i> , 1998 Supercritical Fluid Chromatography combined with GC and GC-MS for the analysis of complex petrochemical mixtures Ph.D (Chemistry) Comprehensive two-dimensional supercritical fluid and fast temperature programmed gas chromatography, Feb 2003
Awards	2 nd Prize for the most commercially viable innovation developed at a South African university during 2002 Organized by Catalyst Innovation (NGO), Acorn Technologies and Deloitte and Touche.
Bursaries	Foundation for Research and Development Grand-holder bursary: M.Sc (1996-1997) Ph.D (1998-2001)
University Activities	Die Perdeby (Student Newspaper) Editing Staff – 1994-1995 Tuks Student Wine Culture Society 1995 (Committee Member: marketing) 1996 (Chair Person) Department Chemistry Social Club 1998 (Treasurer)

RESEARCH – GENERAL FIELDS OF INTEREST

Chromatography, Multidimensional Chromatography, Hyphenated techniques, Mass Spectrometry, Fast GC, Instrumentation Design, Analytical Chemistry.

SCIENTIFIC PAPERS PUBLISHED IN INTERNATIONAL JOURNALS

The analysis of paraffin, olefin, aromatic and oxygenate groups in petrochemical mixtures by supercritical fluid chromatography on silica gel.

A. Venter, E.R. Rohwer, A.E. Laubscher, J. Chromatogr. 847 (1998) p 309-321.

Performance optimization of a fast temperature programmed, resistively heated GC with thermocouple sensing.

A.Venter, E.R.Rohwer

Submitted for publication to Analytical Chemistry

Comprehensive two-dimensional supercritical fluid and gas chromatography (SFCxGC) with independent, fast programmed heating of the gas chromatographic column.

A.Venter, E.R.Rohwer

Submitted for publication in Analytical Chemistry

Group type analysis of oxygenated compounds with a silica gel PLOT column and comprehensive two-dimensional supercritical fluid and gas chromatography

A.Venter, P. Makgwane, E.R.Rohwer

To be submitted for publication in Analytical Chemistry

PATENTS

Instrumentation for chemical analysis

A.Venter, E.R. Rohwer

May 2002

Status: South African Provisional patent

CONFERENCE PROCEEDINGS

Instrumentation for comprehensive two-dimensional fast temperature programmed gas chromatography

A.Venter, E.R.Rohwer

Poster presented at Analitika 2002 – Stellenbosch, December 2002

Dehydrohalogenation of isotopically enriched R22 (CHClF_2) to methane

A.Venter, H.J.Strydom, E.Ronander

Poster presented at Catsa 2002 conference, Cape Town, November 2002

New instrumentation for comprehensive SFCxGC

E.R.Rohwer, A.Venter

Lecture presented at 25th Symposium on capillary chromatography, Riva del Garda, Italy, 2002

Oxygenate group separation by supercritical fluid chromatography coupled comprehensively to fast programmed gas chromatography

A.Venter, E.R.Rohwer

Poster presented at 25th Symposium on capillary chromatography, Riva del Garda, Italy, 2002

Instrumentation for comprehensive two-dimensional supercritical fluid and independent fast-temperature-programmed gas chromatography

A.Venter, E.R. Rohwer

Poster presented at 25th Symposium on capillary chromatography, Riva del Garda, Italy, 2002

Oxygenate Group Analysis – Group Separation of Various Oxygenates using Sub-critical CO₂ and a Silica Gel PLOT column.

A.Venter, E.R. Rohwer, A.E. Laubscher

Poster Presented at Mass Spectrometry – Chromatography 2000 – Warmbaths, October 2000.

Supercritical fluid chromatography of petrochemical mixtures.

A.Venter, E.R. Rohwer, A.E. Laubscher

Poster presented at Analitika 98, Midrand, October 1998

Instrumentasie vir volledig twee-dimensionele superkritiese fluide en gas chromatografie.

A.Venter, E.R.Rohwer

Lecture presented at Student symposium of Die Afrikaanse akademie vir wetenskap en kuns, October 2001.

The Analysis of Paraffin, Olefin, Aromatic and Oxygenate Groups in Petrochemical Mixtures by Supercritical Fluid Chromatography on Silice Gel.

A.Venter, E.R. Rohwer, A.E. Laubscher

Poster presented at 22nd International Symposium on Chromatography, University of Rome, Rome, September 1998.

Supercritical Fluid Chromatography Combined with GC-MS for the Analysis of Complex Petrochemical Mixtures A.Venter, E.R. Rohwer, A.E. Laubscher

Lecture at SACI Young Chemists Symposium, University of the Witwatersrand, Johannesburg. 26 June 1998.

Quantitative Analysis of Petrochemicals by Supercritical Fluid Chromatography

A.Venter, E.R. Rohwer, A.E. Laubscher, M. Probst.

Quantitative Analysis of Petrochemicals by Supercritical Fluid Chromatography

A.Venter, E.R. Rohwer, A.E. Laubscher, M. Probst

Poster at Mass Spectrometry – Chromatography 1996, Christiana, August 1996.

PROFESSIONAL BACKGROUND

Professional Affiliations	Member of The South African Chemical Institute, ChromSA, SAAMS.
	Member of The South African Association for the Advancement of Science (S2A3).

EMPLOYMENT HISTORY

Current Position

Company	Scientific Development and Integration (Pty) Ltd
Position held	Chemist
Commencing	February 2002
Duties	Analysis of isotopically enriched carbon compounds Design of catalytic processes for conversion of gaseous, isotopically enriched molecules. Liaison and interaction with contractors. Establishment of a commercial scale cryogenic distillation facility for separation of gaseous isotopically enriched carbon compounds.

Previous Experience

Name of Organization	Ampath Pathologist
Position Held	Student Technologist
Duration of Employment	October 1999 – November 2001
Duties	On site analysis of urgent medical specimens Co-ordination of administrative and nursing staff during after-hours shifts
Name of Organization	University of Pretoria
Position Held	Part Time Junior Lecturer
Duration of Employment	1 January 1997 – 31 December 2001
Name of Organization	University of Pretoria
Position Held	Tutor (Bridging Course)
Duration of Employment	1 February – 30 November 1996
Name of Organization	University of Pretoria
Position Held	Research Assistant (Dr. H.M. Roos)
Duration of Employment	July – November 1994
Name of Organization	Experilab
Position Held	Part Time Laboratory Assistant
Duration of Employment	August – November 1993

