

Lectures 11 to 18**Module II - Manufacturing Techniques****Manufacturing Techniques**

There are plenty of methods to cast a composite structure whether it is simple or complex, single or multiple. Each method has its own merits and limitations. Selection of particular manufacturing process is based on the type of matrix and fibers, temperature to form and cure the matrix, the geometry of the end product and cost effectiveness.

The two important parameters that control the manufacturing techniques are temperature and pressure. High temperature is required for the chemical reaction of resin to prevail whereas pressure is required for the highly viscous resin to flow into the fibers and to bind the fibers which are initially unbonded. The chemical reaction of resin forming cross linking is called curing. The time required to complete the curing is called the cure cycle.

Degree of cure

The degree of cure at any time, t is defined by

$$\alpha_c = H/H_R \quad (2.1)$$

where, H - the amount of heat released in time t

H_R - heat of reaction

The degree of cure is determined experimentally using Differential Scanning Calorimeter (DSC).

This detail will be useful in processing composites.

Gel time:

On curing, the viscosity of the matrix increases with increasing cure time and temperature. The rate of viscosity increase is low at the early stage of curing. After a threshold degree of cure is achieved, the resin viscosity increases at a very rapid rate. The time at which this occurs is called the gel time.

Gel time test:

This test is conducted to determine the curing characteristics of a resin-catalyst combination. The procedure of the test is as below:

1. Take resin and catalyst and mix them thoroughly.
2. Pour the mix into a standard test tube which is suspended in a 82°C water bath.
3. Insert a thermocouple in the test tube to monitor the temperature rise.
4. Record the time and the corresponding temperature rise.
5. Plot the graph Time vs Temperature.
6. From the graph, note down the point at which there is a sudden rise in temperature. The time corresponding to that point gives the gel time.

The typical gel time graph is shown in Fig.2.1.

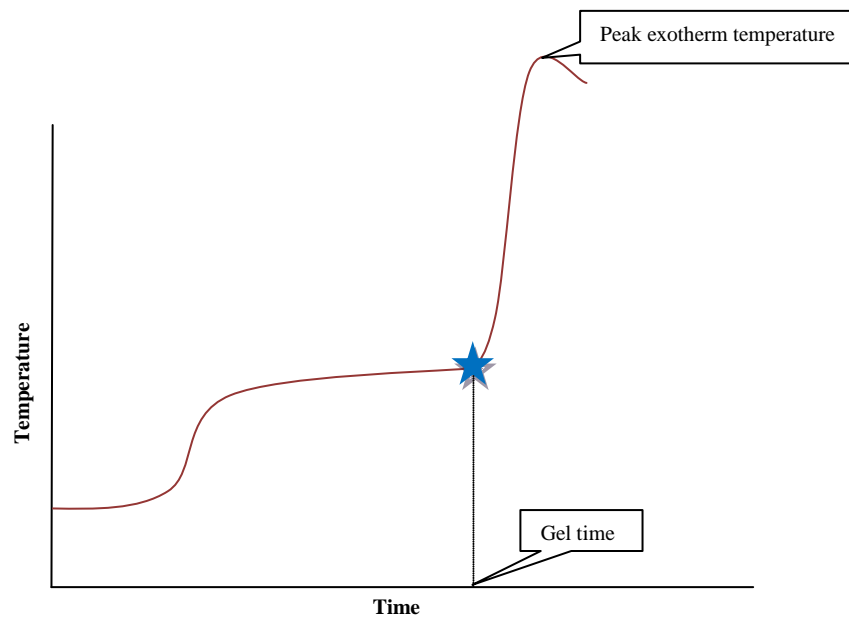

Figure 2.1 Temperature-time curve in Gel time test

Types of Composite Manufacturing:

Composites are manufactured through different techniques. The techniques are chosen based on type of fiber, resin and the size of the product. Some of the commonly used manufacturing techniques are given below.

- ✚ Lay-up
 - Hand lay-up
 - Spray lay-up
 - Prepreg Lay-Up
 - Automatic tape lay-up
- ✚ Prepregs
- ✚ Compression molding
 - Resin injection molding
 - Incremental molding
 - Stamp molding
 - High-pressure compression molding
 - Injection molding
- ✚ Bag molding
 - Pressure bag molding
 - Vacuum bag molding
- ✚ Autoclave molding
- ✚ Filament winding
 - Helical winding
 - Hoop winding

- ✚ Resin transfer molding (RTM)
 - Flexible RTM (FRTM)
 - Continuous RTM (CRTM)
 - Vacuum assisted RTM (VARTM)
 - High-speed RTM (HSRTM)
- ✚ Pultrusion
- ✚ Molding compounds
 - SMC (sheet molding compound)
 - BMC (bulk molding compound)
- ✚ Centrifugal Casting
- ✚ Extrusion method
- ✚

(i) Prepregs:

Pre-impregnated fiber materials are called as prepregs. No thickening agent is used in making prepregs. Prepregs have a higher fiber content of 65%. They are available in both cloth or tape form. Usually, woven cloths are pre-impregnated, but woven rovings and chopped strand mats are also pre-impregnated.

Characteristics of good prepreg

1. The fiber to resin ratio should be high and should not vary from place to place.
2. Volatile contents and solvents should be minimum.
3. The prepreg should be flexible and tack free.
4. The material should have long storage life.
5. During moulding, the resin should be soften and flow filling the mold cavity should be without voids and defects.

Materials

Glass fiber is the most commonly used as reinforcing material, but other fibers like carbon fiber, boron have also been used. Epoxy and polyester resins are used as the impregnating agents.

Preparation of prepregs**a. Method:**

Prepregs can be made by basically two methods:

1. Wetting the glass fiber cloth with the resin and heating it to a B-stage of curing (partial curing) so that the material becomes tack free. After sometime, if the heat is withdrawn and the material is stored at -18°C the cross linking operation can be stopped. At the correct B-stage the cloth will be tack free and very flexible. The prepregs are slightly

heated before processing to get soften and bond with the successive layers. After shaping (winding, press moulding), the material is heated to take it to the full cure.

2. If the matrix is in powder form it cannot go through the B-staging. In such cases, the resin is dissolved in a suitable solvent and brought to required viscosity.

b. Equipment:

The Machine used for manufacture of prepreg is called Tower. Fibers tensioned by tensioning device are passed through resin bath. It is then passed through a set of scrap bars to squeeze out the excess resin. The wetted fibers are then passed through drying oven, where temperature gradually increases. Volatiles are removed and resin reaches a tack free stage called B-stage. The prepreg fibers are covered by polythene sheet and completely rolled in aluminium foil.

c. Storage Condition:

The prepregs are stored in refrigerated chambers. The temperature of the storage area is important in improving the shelf life of the material. Moisture should be completely avoided. Shelf life is 6-8 months when stored at -18°C .

Evaluation of Prepregs:

Parameters to be evaluated in cured state are:

1. Weight per unit area
2. Tackiness and durability
3. Resin content
4. Fiber content
5. Volatile content
6. Resin flow

(ii) Hand layup method:

It is the oldest molding method for making composite products. It requires no technical skill and no machinery. It is a low volume, labor intensive method suited especially for large components, such as boat hulls. A male and female half of the mould is commonly used in the hand lay-up process. A typical structure of hand lay-up product being made is shown in Fig.2.2.

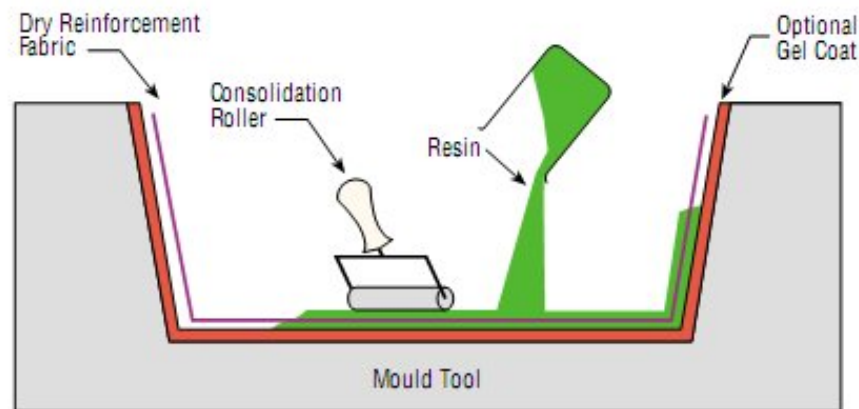

Figure 2.2 Hand layup method

Mould:

The mould will have the shape of the product. In order to have a glossy or texture finish on the surface of the product, the mould surface also should have the respective finish. If the outer surface of the product to be smooth, the product is made inside a female mould. Likewise, if the inner side has to be smooth, the moulding is done over a male mould. The mould should be free from defects, since the imprint of any defect will be formed on the product.

Release Film or Layer:

Since, the resins used are highly adhesive, the product may get stuck to the mould. So, a proper releasing mechanism should be incorporated. The release of the product can be affected.

- By the use of a release layer of wax or polyvinyl alcohol (PVA).
- By using a thin film like polyester film (Mylar).

Since, the Mylar sheet has to be fit into the mould profile, this method is not used for complex shapes.

Gel coat:

The gel coat gives the required finish of the product. It is usually a thin layer of resin about mm thickness applied on the outer surface of the product. The colour is obtained by adding appropriate pigments to the resin. The gel coat forms a protective layer that protects the glass fiber getting in contact with water and chemicals.

If the gel coat is too thin, the fiber pattern will become visible. If it is too thick, crazing and star crack can appear on the gel coat.

Surface Mat Layer:

A surface mat layer will be placed beneath the gel coat layer. The fibers of the mat will not give high strength like reinforcement fibers, but the mat provides crack resistance and impact strength to the resin rich layer. It is an optional layer used only in specific cases.

Laminates of Glass Fiber:

The glass fiber layer wetted with resin is laid up one after another to the required thickness and this finished material is called the laminate. The laminate gives the strength and rigidity to the product. Glass fiber in the chopped strand mat (CSM) is commonly used to get composite products. Woven roving, unidirectional and bi-directional mats are also used to get high strength composite products.

Finishing surface mat layer / resin coat:

The glass fiber laminate provides a rough surface finish. In order to get a smoother surface, a surface mat layer or resin coat may be applied over the laminate layer and smoothed by placing a thin Mylar film layer.

ADVANTAGES

It is a low volume, labor intensive method suited for many products such as boat manufacturing, automotive components, ducts, tanks, furniture, corrosion resistant equipment etc.

No costly machinery is required.

Nearly all shapes and sizes can be made.

Colour and texture finish can be obtained by this hand lay-up method.

LIMITATIONS

The quality of the product depends on the skill of the operator.

It is not suitable for mass production of small products at high speeds.

It is difficult to get a void free composite product

SELECTION OF HAND LAY-UP AS A FABRICATION PROCESS

The following conditions favor hand lay-up as the method of fabrication.

- Only one side need to have good smooth finish.
- The product is large in size and very complex in shape.
- Only a few numbers of mouldings are required.

MOULDS

Open mould process of FRP fabrication makes use of either male or female mould. Open mould hand lay-up can be done in moulds made out of plaster of paris, wood, FRP, or metals. Plaster of Paris mould is good for one or at most two pieces since the mould may break during the release of product. Wooden mould requires finishing work on every cycle of moulding. FRP moulds are ideal for complex shapes. When heating and pressing is required, metallic moulds are preferable.

Material Selection:

Plaster of Paris, teak or rose wood, FRP, aluminium and die steel are good materials for making moulds.

Mould Thickness:

Since, GRP is a costly material, the right thickness shall be chosen for GRP moulds. For a small complex shape product the mould thickness should be double the thickness of the product. For large size products in order to make economical, ribs or stiffeners are to be used rather than increasing the mould thickness. To avoid the warping of the mould, suitable flanges or stiffeners must be provided all round the edges.

Mould Trim Line Size:

In hand lay-up the products are made with additional dimensions so that the product will have the required dimension after trimming. In case of cold pressing, extra space must be given to the mould for holding the excess resin squeezed out during pressing. This can be achieved by placing about 1/2" wide extra fiber mat all round which will act as a bleeder layer to absorb the resin.. The mould dimension is to be slightly larger than the product to hold the trim lines and bleeder layers. A bleeder layer is a synthetic material , available in variety of thicknesses and weights. It provides continuous air path for the pulling of vaccum from the composite products.

Mould Taper:

For deep drawn products a taper has to be provided for ease release. It is a common practice that a 1 in 1000 taper for epoxy and a 1 in 100 taper for polyester are found to be adequate for easy release.

Split Mould Design:

For large size and complex shaped products split moulds have to be provided. Flanges are provided at the two halves and it is connected by the bolted joints. The flange area should be 50% thicker than the mould shell thickness. A minimum flange width of 30mm with staggered bolting array may be provided.

Pattern and Pattern Making:

For a small size product the mould is made by carving the wood. If the mould is made by GRP means it requires a pattern. For a large size and complex shape product like automobile body plaster of Paris is recommended.

Plaster of Paris Pattern and Moulds:

The procedure for making mould and pattern making by plaster of Paris are the same. If the thickness is more than 15 to 25 mm, the plaster will take more time to set. So the construction should be such that there should not be any cracking. To prevent cracking chopped fibers will be added to the plaster.

Plaster moulds or patterns can be done by different methods which include, Rotational sweeping, linear sweeping, by using template and by sculpturing.

Rotational sweeping:

If the product has an axi-symmetric shape, the pattern can be shaped by rotating the template having the profile of the product to reproduce the shape.

Linear sweeping:

It is used for product having same profile along its length.

By using templates:

If the product is of irregular shape, templates can be prepared to represent the product profile and to locate at their respective positions. The space between the templates is filled with plaster of Paris.

By sculpturing:

It is used to carve a profile from the cast plaster of Paris.

Since, the plaster of Paris has a porous surface it is smoothened with non-oil based putty like nitro cellulose putty or Duco putty. Finally, the Duco putty thinner is sprayed on the surface and polished with 400 grade emery sheet to have a smooth finish.

MOULD PREPARATION AND APPLICATION OF RELEASE AGENTS

The mould should be thoroughly cleaned and free from dirt's before the releasing agent is applied. Then, the mould surface is coated with silicone free wax (e.g. mansion polish). After some time the wax has to be removed to have a glassy finish on the mould surface. In certain cases release of the product is difficult with wax alone. So, a layer of poly vinyl alcohol (PVA) is applied. Since, PVA is water soluble material, 15% solution in water is applied with sponge. The brush application will leave the prints of brush lines so, sponge is preferable. After the water evaporates, a thin layer of PVA forms on the mould surface. The PVA layer must be completely dry before the gel coat is applied perhaps it will create wrinkles called 'elephant skin'. MEK or cellulose acetate, casein, carboxyl-methyl cellulose and methyl cellulose are the other film formers used as releasing agents.

GEL COAT APPLICATION

The gel coat resin is generally of the same as the matrix material used for making the composite product. The gel coat resin is prepared by adding 2 to 3 % of aerosol powder to the resin and stirring it well. The aerosol powder provides the required thixotropy. It is a property by which a liquid which remains as a thick viscous fluid with very little flow, but when some external force is applied (like stirring it well), it flows easily like a relatively low viscous fluid.

The viscosity of the resin can also be increased by adding fine calcium carbonate or other fillers. The filler percentage must be as low as possible otherwise, the cured resin will become brittle.

Pigments can be added with the resin to get the required colour. Titanium dioxide and carbon black will give white and black colour respectively. For products exposed to sunlight, UV stabilizers must be added to the gel coat resin. The required quantity of gel coat mix for a batch of same colours can be mixed at a time by adding pigments and accelerator to avoid colour variation.

Gel coat resin when applied must be free from air bubbles and dirt. About 600 gms. of resin will be required to give 0.5 mm thick gel coat on one sq. m. area. This will be applied as two coats. The second coat will be applied after the first coat is cured.

SURFACE MAT LAYER

The surface mat layer must be applied only after the gel coat is cured. Otherwise the surface finish will be affected. The surface layer can be any one of the following.

- Glass fiber surface tissue mat.
- Polyester woven cloth of fine thickness
- Nylon woven cloth of fine thickness

A thin layer of resin is applied over the surface and the mat is wetted with brush. It may also be lightly rolled with roller to remove the air bubbles.

LAY-UP OF LAMINATES

The lay-up should start as soon as the gel coat layer is cured. The lamination should satisfy the following requirements:

- a) The fiber layers should be uniformly placed and they should fit correctly into the contour of the product.
- b) The fiber should not be damaged during lay-up
- c) The fiber to resin ratio should be correctly maintained.

Preparation of the Resin Mix:

The resin mix can be prepared at least one day ahead so that the entrapment of air bubbles escape before the lay-up begins. The mix consists of the resin, accelerator, fillers, and additives if any. The addition of accelerator to resin will not cause any cross linking until catalyst is added. The mixing can be done by either manually using a paddle or by using an air operated mixer.

Vigorous stirring can cause entrapment of air bubbles therefore; mixing should be done at a very low rpm. The container in which resin mix is stored may be closed air tight to minimize the vaporization and loss of styrene.

Preparation of the color fiber Mat:

The required number layers to obtain the thickness can be determined by taking into account the mat density and the glass-to-resin ratio by weight. The following points must be taken into account while preparing the mat:

Wherever joints are there, there should be a minimum overlap of 25 mm, in case of chopped strand and a 50 mm overlap is required in the case of woven roving mat.

Whenever, there is change in thickness the thickness must not abruptly change and instead it must gradually change.

Tools for Lay-up:

1. Weighing balance - to weigh the chemicals.
2. Brushes - to apply resin for both gel coat application and for lamination.
3. Rollers - to remove the air bubbles and also for applying resin.

Long rollers are used to consolidate large areas but short rollers are used for corners and curved surfaces.

Mugs and small bowls - for taking the resin mix for lay-up.

Solvents:

Solvents are required for cleaning the rollers and brushes during or after the lay-up sequence is over. Acetone or nitrocellulose thinner can be used as solvents.

Lamination procedure:

In the process of lamination a thin layer of resin is applied on the gel coat layer. Then, a chopped strand mat is placed over it. The resin is again applied over the mat by using brush to wet the mat. By using the roller the air bubbles are removed.

After the first layer is laid up, subsequent layers are laid in a similar manner. More than, 4 layers of resin and glass mat should not be applied without allowing the resin to cure at a time. When WRM is laid up, CSM is used in between in order to increase the inter-laminar shear strength. The lay-up procedure for WRM and CSM are identical except that the resin used for WRM is half the quantity of that is needed for CSM.

Curing of Resin:

The curing of resin process undergoes through four stages:

Gelation Stage:

It is the stage at which the resin becomes tack free and unworkable. It depends on the percentage of catalyst and accelerator added. Normally, it takes 15 to 30 minutes to gel.

Green Stage:

This is the stage at which the resin resembles to hard cheese which when pressed with the thumb it breaks up. The resin is considered to be set but not cured.

Cured Stage:

It is the stage at which more than 90% of the cure is completed. The product can be released from the mould after this stage.

Fully Cured Stage:

It is the stage at which the physical properties of the moulding are developed. Normally, it takes 5 to 10 days. At a fully-cured state, GRP will produce a metallic sound if it tapped with a coin.

Release of the Moulding from the Mould:

This process should be done very carefully. Any of the following methods can be used for releasing the product.

Construct a 'grapple' point in the part so that when a hoist is engaged to lift upwards, the weight of the mould will cause to drop it off.

Wedges are inserted into the flange and by tapping it all around the mould; the two halves will be dropped.

(iii) Pultrusion:

Pultruded composites consist of fibers predominantly in axial directions impregnated by resins in order form a most efficient composite product. Surface mats are used for surface appearance and also to improve chemical and weather resistance. Polyester resins are widely used in the pultruded products.

Pultrusion process:

The pultrusion process (Fig.2.3.) generally consists of pulling of roving/ mats through performing fixture to take its shape of the product and then heated where the section is cured continuously.

Description of Pultrusion Machine:

The following are the facts of Pultrusion machine and the details of these facts are given below.

- a. Creel.
- b. Resin wet out tank
- c. Forming dies
- d. Heated matched metal die
- e. Puller or driving mechanism.
- f. Cut-off saw.
- g. Mandrel (for Hollow shapes)

a. Creel:

Creel generally consists of bookcase type shelves where rovings from individual packages are pulled out for a resin bath. Metal book shelves are best

since they can be grounded to avoid static charges produced. Vinyl tubes are installed to avoid the roving crossing over each other, as it generates “fuzz ball” to build up in the resin mix tank raising its viscosity.

b. Resin wet out tank:

The resin bath or wet out tank generally consists of sheet metal of aluminum through series of rolls. A grid or comb is attached at the entry and exits of resin wet out tank in order to maintain horizontal alignment and also to avoid the excessive resin.

c. Preforming Fixtures:

These fixtures consolidate the reinforcements and move them closer to the final shape provided by the die. Generally, fluorocarbon or ultra high molecular weight polyurethanes are used as fixtures since these are easy to manufacture and also it is easy to clean it for later purpose.

d. Heated Dies:

The chrome plated matched metal die maybe heated by electrical cartridges or by strip heaters. Thin sections are generally used by conduction of heat. In case of thick section the curing can be speeded up by using both radio frequency (RF) radiation and conductive heat.

e. Pulling Section:

A pair of continuous caterpillar belts containing pads are used for pultrusions. A double set of cylinders with pad pullers can be synchronized for an intermittent pull.

f. Cut-Off saw:

A conventional saw with an abrasive or a continuous rim diamond wheel with coolant is generally used for cutting the desired product.

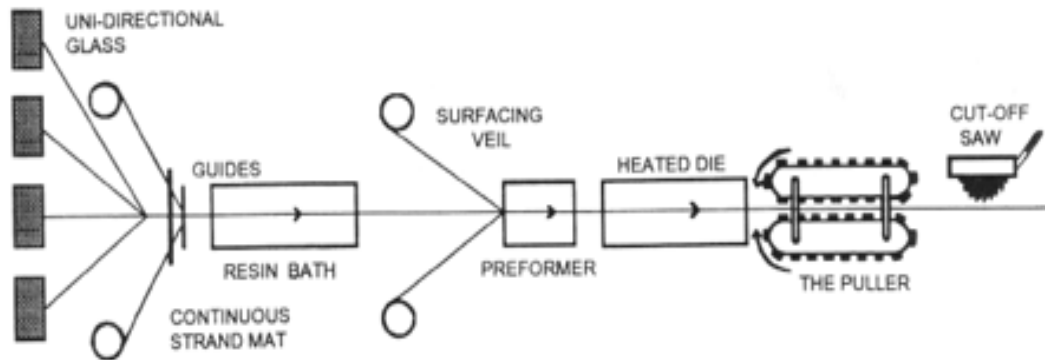

Figure 2.3 Pultrusion method

The pultruded sheet consists of both CS rovings as well as mat layers. Mat layers are added to increase the transverse strength. Generally, the matrix materials used in pultrusion are polyester and vinyl ester from thermoset polymers (epoxy has long cure time) and PEEK and polysulfone from thermoplastic polymers.

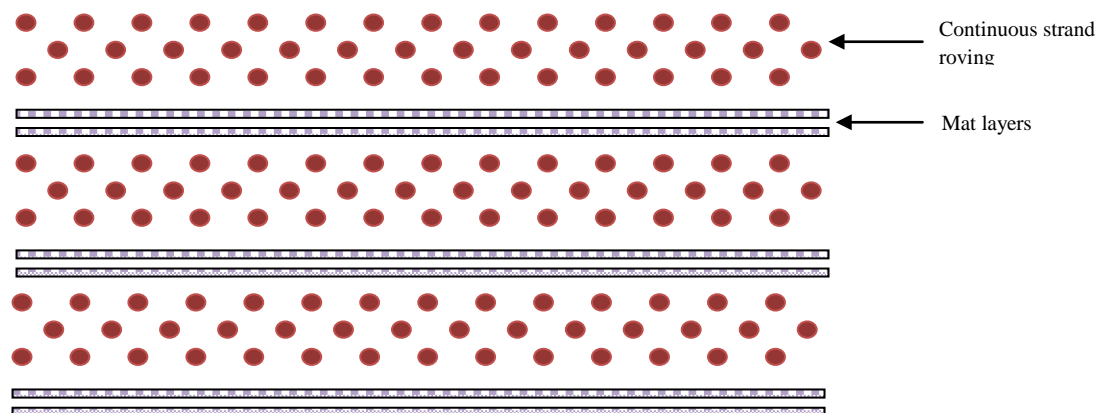

Figure 2.4 Pultruder sheet

The pultruded sheets (Fig.2.4.) are pulled through a liquid resin bath to thoroughly wet every fiber. The reinforcements are then guided and formed, or shaped, into the profile to be produced before entering a die. As the material progresses through the heated die, which is shaped to match the design profile, the resin changes from a liquid to a gel, and finally, into a cured, rigid plastic.

A pulling device grips the cured material and literally pulls the material through the die. It is the power source for the process. After the product passes through the puller, it is sawed into desired lengths. Although pultrusion is ideally suited for custom shapes, some standard products include solid rods, hollow tubes, flat sheets, hat sections bars, angles, channels, and I-beams.

Applications of Pultrusion:

- Electrical application including transformers.
- Supports in bridges and structures.
- Automobiles.
- Pipes and rods.

Pultrusion part design:

1. FRP property design criteria:

The design factor and load factor are to be considered before producing the product based on the application. It is necessary to depict its ultimate strength for safe operations. Apart from it various other properties like thermal and electrical properties are to be determined.

Table 1.25 Designs

| Type of Loading | Minimum Design Factor |
|--|-----------------------|
| Static Short-term loads | 2.0 |
| Static Long-term loads | 4.0 |
| Variable or changing loads | 4.0 |
| Repeated loads, load reversal, fatigue loads | 6.0 |
| Impact loads | 10.0 |

Pultrusion part design principles:

In this section the principles of product manufacturing and the handling factors of the product are discussed.

Table 1.26 Details of Pultrusion process

| | |
|----------------------|---|
| Size | Shaping die and equipment pulling capacity influence size limitations |
| Shape | Straight, constant cross sections, some curved sections possible |
| Reinforcements | Fiberglass Carbon fiber Aramid fiber |
| Resin Systems | Polyester Vinyl ester Epoxy Silicones |
| Fiberglass Contents | Roving, 40-80% by weight Mat, 30-50% by weight Woven roving, 40-60% by weight |
| Mechanical Strengths | Medium to high, primarily unidirectional, approaching isotropic |
| Labor intensity | Low to medium |
| Mold cost | Low to medium |
| Production rate | Shape and thickness related |

2. Structural shapes:

Early pultruded structural shapes were made to conform to standard steel practice. It was found out that since FRP shapes were heterogeneous materials and their shrinkage due to cure was subject to the type and quantity of resin used, warpage was a problem. These structural shapes should contain continuous strand mats as well as continuous

rovings. An uneven number of plies of continuous strand mat are used with rovings placed between each two layers of mat.

Pultrusion die design:

Pultrusion dies are considerably simpler in construction than most matched mould dies.

a. Die Steel:

Any good tool steel can be used to make a Pultrusion die. Coated dies are in trend in order to withstand heat and also to avoid corrosion. Ceramic coated steel dies have been successfully used.

b. Bell Mouth entrance:

In order to assist the wet reinforcements to enter the mould a bell mouth is machined around the shape periphery. As the part size increases in width and area this bell mouth should be used for very large structural shapes.

c. Mounting Provisions:

The die must be fastened to the heating platens with clamps or bolts. A less expensive and reliable method is to fasten the dies to the platens with bolts and angle clamps.

d. Die surface finish:

All internal mould surfaces that see the FRP materials should have a good mould finish. Final polishing should be in longitudinal direction.

e. Chrome plating:

The internal areas of the Pultrusion die through which the materials are pulled must receive a hard chrome plate to provide a long working life for the die.

f. **Heating:**

Pultrusion dies are to be heated with strip heaters, electrical cartridge heaters, or cored for hot oil. After it became useful to have several zones with different controlled temperatures and a different temperature at start up than during operation. The use of electrical cartridge heaters with thermocouple has now almost become a standard practice.

g. **Cold Junction:**

A cold junction is used on the portion of the die that extends outside the heated platen area. Cooling water should enter the bottom cold junction port first and then the top plate as to insure that air pockets do not collect in the system.

(iv) Compression molding:

It is considered as the primary method of manufacturing for many structural automotive components, including road wheels, bumpers, and leaf springs. It is done by transforming sheet-molding compounds (SMC) into finished products in matched molds. It has the ability to produce parts of complex geometry in short periods of time. It allows the possibility of eliminating a number of secondary finishing operations, such as drilling, forming, and welding. Moreover the entire molding process can be automated.

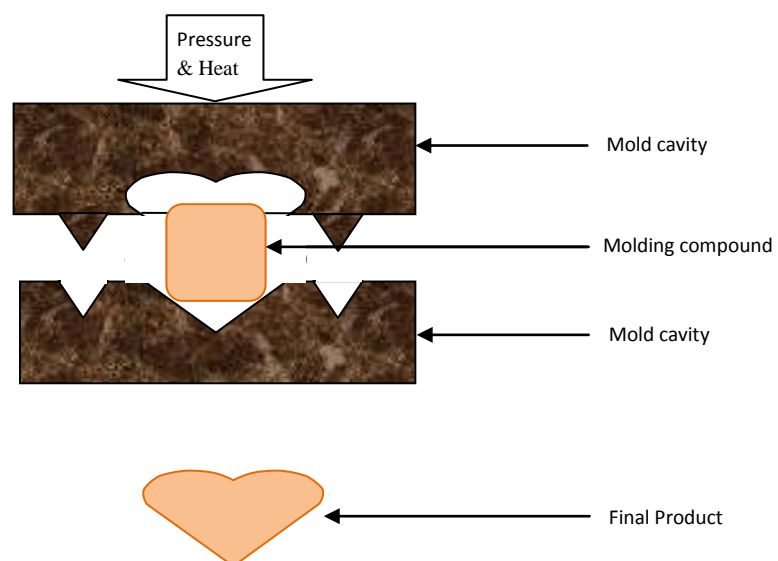

Figure 2.5 Compression molding

The molding compound is first placed in an open, heated mold cavity. The mold is then closed and pressure is applied to force the material to fill up the cavity. A hydraulic ram is often utilized to produce sufficient force during the molding process. Excess material is channeled away by the overflow grooves. The heat and pressure are maintained until the material is cured. The final part after the mold is removed. The molding pressure may vary from 1.4 to 34.5 MPa and the mold temperature is usually in the range of 130°C to 160°C. To decrease the peak exotherm temperature which may cause burning and chemical degradation in the resin, filler may be added. The time to reach peak exotherm is also reduced with increasing filler content, thereby reducing the cure cycle. The cure time may also be reduced by preheat process.

There are two different types of compounds most frequently used in compression molding: Bulk Molding Compound (BMC) and Sheet Molding Compound (SMC). SMC costs higher but can be pre-cut to conform to the surface area of the mold.

Types of Compression Moulding

- i. Hot pressing in which the moulding charge is heated while shaping.
- ii. Cold pressing which uses a wet lay-up process and the product is pressed to the required shape, but cured without the application of heat.

Advantages

- i. Good finish on both sides.
- ii. Faster production.
- iii. Uniform product quality.
- iv. Less labor content.
- v. Very little finishing operations required.

Disadvantages

- i. This process is not suited for low volume of production because of high cost of moulds and press.

- ii. The process is also not suitable for very large sized products.

Equipment:

The Press:

The function of the press in the compressing moulding is to supply the pressure required for moulding the products. There are various types of presses available eg. mechanical, pneumatic and hydraulic. Since, pressure required for GRP are high. Hydraulic presses are mostly used.

Moulds:

Moulds give shapes to the moulding charge. Dimensional accuracy and surface finish of the moulded product depends mainly on the dimensional accuracy of the moulds and it has to be very high. Mould surface should have high class surface finish and resistance to abrasion, since several thousand products have to be obtained from one mould.

Mould Materials

Requirements of mould materials are

- i. High strength
- ii. High toughness
- iii. High Hardness Value
- iv. Good Abrasion Resistance
- v. Good Machinability
- vi. Good weldability
- vii. Good Polishability

Three general types of steel are used for mould construction

- i. Pre-toughened steel
- ii. Case hardening steel

iii. Air hardening steel

Alloy steel AISI-4140 or its equivalent IS-40 C 1 Mo 28 or EN19C pre-hardened to Rockwell C30-32 is used for high class moulds.

Types of Moulds

There are five standard designs for compression mould cavities and forces, these are

1. Flash type mould:

This design is not recommended, since parts produced may be of poor quality. However, it may be used for large parts made from BMC or SMC.

2. Fully positive mould:

It is used for large deep draw where maximum density is required.

3. Landed positive mould:

These are multi-cavity moulds. Multi-cavity mould may be this type of mould. Vents are incorporated on the force to permit maximum density.

4. Semi-positive vertical flash mould:

These are more suited for automatic moulding

5. Semi-positive vertical flash mould:

This is used when no visual flash line mark is permitted on the moulded parts. Mold costs are more because of two areas of proper fit between force and cavity.

(v) Resin Transfer Molding (RTM):

It is also called as liquid molding. It is a low pressure closed molding process for moderate volume production quantities. Dry continuous strand mats and woven reinforcements are laid up in the bottom half mold. Preformed glass reinforcements are often used for complex mold shapes. The mold is closed and clamped, and a low viscosity, catalyzed resin is pumped in, displacing the air through strategically located vents. The injection pressure of resin is in the range of 70-700 kPa.

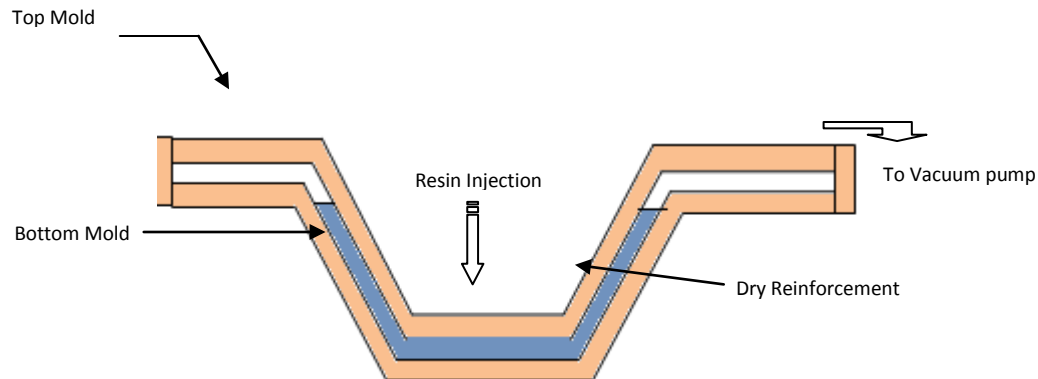

Figure 2.6 Resin Transfer Molding

Advantages and limitations

Unlike in hand layup, RTM process gives better control on product thickness and good finish on both sides. It is not essential to have metallic moulds because the product curing is generally done under ambient temperature. By applying gel coats on both sides, the product will have a smoother finish on both sides.

When the injection pressure is increased, as in very closely packed fibers, there is a tendency for fiber wash. This tendency can be countered by using continuous strand mats or special woven performs. Inserting of wood, foam or metal will reduce the secondary bonding. Other advantages can be listed as follows.

1. Controlled usage of fiber and resin reduces the material wastage and unit cost
2. A variety of mould shapes and sizes can be moulded sequentially because of the mobile pumping unit.
3. Styrene emission is practically eliminated during resin transfer into the mould.

There are few limitations which require special attention. Some of the limitations are given below:

1. Since, this process can develop pressures up to 5 to 10 bars, tool rigidity and clamping techniques have to be designed for such pressures.
2. Handling of large and heavy moulds requires adequate lifting equipments.
3. Unlike in compression moulding, post trimming is required for this process.

PROCESS EQUIPMENT AND TOOLS

Types of RTM machines

The machines used for RTM include a mixing head attached to a nozzle, a pumping unit, and a solvent flushing unit. The pumping unit generates the pressure to inject the resin through the layers of reinforcement. The solvent flushing unit pumps solvent such as acetone to clean the mixing and injection chamber free of resin.

There are three types of RTM injection equipments based on position of mixing of catalyst with resin.

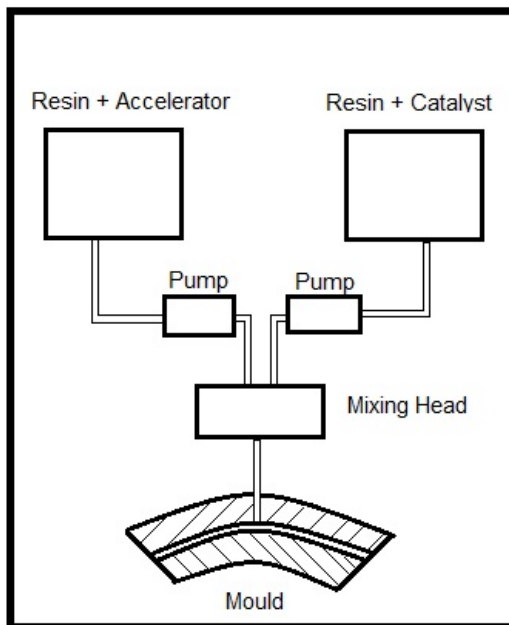

A two pot RTM machine

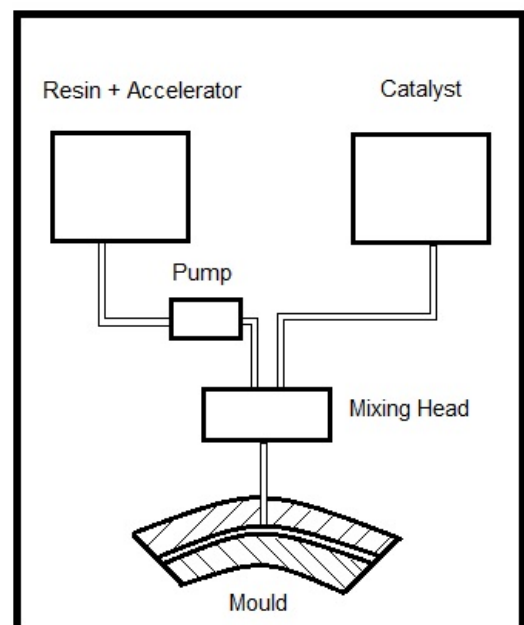

A catalyst dispersing type RTM machine

Figure 2.6a Two pot RTM machine Figure 2.6b catalyst dispersed RTM machine

a. Two pot system

This system has two equal volume containers or pots. In one of these pots the resin is mixed with accelerator. In the other pot the resin is mixed with the catalyst. Two pumps are used to pump these mixtures (as shown in fig.2.6a) to the injection points where they are mixed well in the mixing head.

b. Catalyst injection system

In this system the catalyst is not mixed with the resin until it reaches the entry pot attached to the mould (Fig.2.6b). The resin mixed with accelerator is pumped into the injection chamber. The catalyst is taken separately into the chamber by means of controlling valve. The advantage of this system is that the gel and cure time can be controlled by varying the amount of catalyst added.

c. Pre-mixing system

This is a simple process by mixing the resin, accelerator, and catalyst in a vessel directly and injecting the mixture into the mould. A thick walled airtight metallic cylinder provided with inlet and outlet holes is taken. The injection is carried out through the outlet by means of compressed air. The cylinder has to be washed periodically with acetone to prevent clogging by cured resin.

MOULDS AND MOULD DESIGN**MOULD STRUCTURE**

The mould essentially consists of male and female halves, clamped by a clamping arrangement. Other parts include the injection ports, the air vents, the guide pins, and the gasket along the partition line.

Injection ports:

Injection port is the nozzle through which the resin is injected into the mould. The correct location of injection port is very much essential to ensure proper filling of the mould. As far as

possible, the injection port must be located at the middle so that the resin flows radially to the periphery.

Air vents:

Air vents are provided at suitable locations in the mould for allowing the volatiles and trapped air from the part.

Guide pins:

Guide pins are provided in the mould for guiding the two halves of the mould to a perfect closure without lateral displacement.

Gaskets:

Sealing gasket is provided along the parting line while crossing the mould for preventing the flow of resin through the parting line. Neoprene and silicone can be used as the gaskets.

MOULDING PROCESS**Mould preparation**

The two halves of the mould are cleaned and the dust must be removed from the surface. Wax polish is then applied which helps in easy release of the mould after curing. Over the layer of wax, a film of PVA is applied to aid the release. The disposable inlet and outlet port and air vents are then fitted in position.

Gel coating

A layer of gel coat with appropriate pigment is applied on the surface of both halves of the mould. The gel coat thickness should not exceed 0.5mm.

Fiber packing and mould closure

The calculated quantity of fiber is placed inside the mould. Wherever, the overlap comes, a 25 to 35 mm overlap must be given. The plies near the inlet port can be stitched together otherwise the fiber wash can occur due to injection pressure. The inserts should be placed correctly before

the mould is closed. The clamping of mould has to be tight enough to withstand the injection pressure.

Resin injection and curing

The resin is then injected to the mould using an RTM machine at a calculated pressure. Care must be taken to see that the right quantity of catalyst is dosed into the resin stream and no gelling occurs during pumping. The mixture head has to be pumped with acetone at 15 minutes interval so that the resin does not set within the mixture head.

Demoulding and cleaning

The mould is left undisturbed until the resin is fully cured. For products with large thickness, the high exotherm may lead to degradation of resin hence mould cooling is necessary to reduce the heat. Demoulding is done by removing the clamps and by releasing the mould without any damage to the mould. The product and the mould are then cleaned thoroughly. The product can be polished by using emery paper.

MOULD TIME CYCLE

Total moulding time is given by the relation:

$$T_T = T_{mf} = T_{gel} = T_c = T_u = T_{cl} + T_p + T_{fp}$$

T_{mf} = mould fill up time

T_{gel} = gel time

T_c = cure time

T_u = un mould time

T_{cl} = cleaning time

T_p = preparation time

T_{fp} = fiber packing time

(vi) Filament winding:

Filament winding consists of winding resin impregnated fibers or rovings of glass, aramid, or carbon on a rotating mandrel in predetermined patterns.

The method makes void free product possible and gives high fiber volume ratio up to 80%. In the wet method, the fiber picks up the low viscosity resin either by passing through a trough or from a metered application system. In the dry method, the reinforcement is in the pre impregnated form.

After the layers are wound, the component is cured and removed from the mandrel. This method is used to produce pressure vessels, rocket motor cases, tanks, ducting, golf club shafts, and fishing rods and to manufacture prepregs. Thermoset resins used in filament wound parts include polyesters, vinyl esters, epoxies, and phenolics.

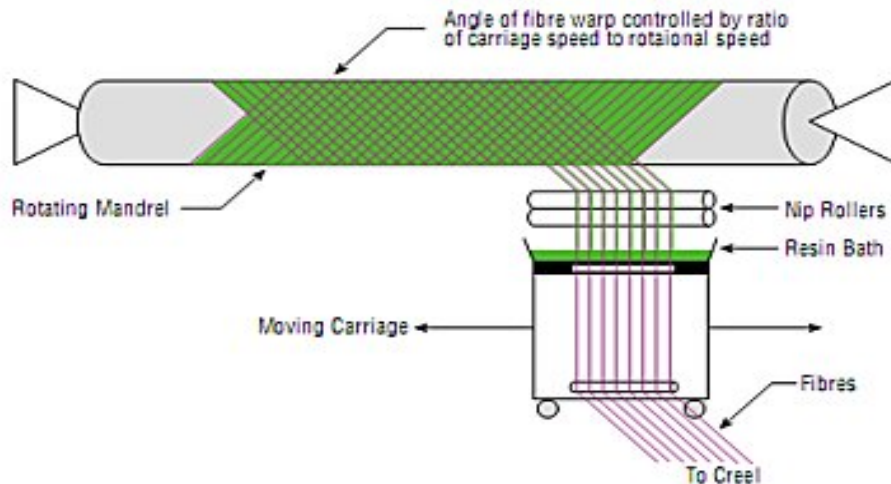

Figure 2.7 Filament winding

This method can be automated and provides high production rates. Highest-strength products are obtained because of fiber placement control. Control of strength in different direction is also possible.

Matrix Application Methods:

The important purpose of the matrix is to bind the filament together and convert into a solid material. The matrix should be free from voids and dirt particles. The matrix application can be divided into seven methods as given below:

a. Wet Winding:

In the wet winding process the matrix in liquid form is placed in a resin bath and the fibers are dipped in that bath and wound. The matrix will be in the liquid form or is brought to liquid form by making a solution. Solids like thermoplastics can be brought to liquid form by melting also.

b. Dry Winding and Liquid Infiltration:

In this process the fibers are initially wound without the matrix and after winding the matrix is allowed to infiltrate into the fibers by pressure injection or vacuum impregnation. The viscosity has to be very low for such impregnations.

c. Dry Winding and Vapour Infiltration:

The fibers are wound first and the matrix is deposited by Chemical Vapour Deposition (CVD) or Physical Vapour Deposition (PVD).

d. Powder Injection:

In this method the matrix material is in the form of powder and is injected into the fibers during winding and then it is converted into solid by sintering or melting.

e. Prepreg Winding:

Prepregs are the fibers, tapes or clothes previously impregnated with the resin. The prepreg will have the fiber to resin ratio correctly maintained. Since the prepregs are in semi solids, winding is more convenient and after winding it is converted into solids by heating or sintering.

f. Winding of Woven or Comingled Fabrics:

In this method the woven fabrics are made by weaving the fiber and the resin which is in the form of fiber. Bundles of reinforcement and matrix filaments are taken as warp and weft fibers and are woven. In the comingled type each bundle of filament will have the matrix and the reinforcement fibers. After winding, the materials are heated to melt the matrix filaments.

g. Plasma Spraying:

The fibers are wound and simultaneously the matrices can be sprayed into it by plasma spraying.

Conversion of Matrix into Solids

This conversion process can be broadly divided into two processes as below.

a. Reactive Process:

In the reactive process the matrix is formed by a chemical reaction which may be a polymerization process as in Reaction Injection Moulding (RIM) or cross-linking process. In the case of carbon-carbon composites, the infiltrated phenolic is converted into graphite by the polymer pyrolysis.

I. Reaction Injection Winding:

In this process the monomers of the polymeric is infiltrated into the filaments. The reaction continues in-situ converting the monomer into a polymer.

II. Polymer Cross-Linking:

Thermoset resins like epoxies, polyesters, phenolics can be made into liquid linear polymer form. Winding is then done with the resins adding the cross-linking additives. The cross-linked operation continued during winding and after winding the liquid linear polymer is converted into cross-linked solid material.

b. Non-Reactive process:

Some of these conversions can be described as follows:

Melt Processing:

Prepregs are first made by coating the fibers with thermoplastics. The prepregs are then used for winding and after winding the thermoplastics are melted and fused into solids. The prepregs can be made by solution impregnation, melt impregnation, film or powder coating etc.

Sintering:

In this process the matrix is in powder form. The fibers are pre-coated with the powder before winding and during winding process the powder is incorporated into fiber by infiltration or powder injection. The powder is subsequently sintered into solid by heating. This method is suitable for materials like polytetra fluoro ethylene (PTFE) which requires very high temperature to melt.

Vapour Deposition:

Vapours of metals, ceramics, carbon etc. can be infiltrated into the fiber which is then cooled to form the matrix.

Advantages of Filament Winding

1. Filament winding is semi-automated which can be done more neatly with less workers.
2. Filament winding can give a fiber content as high as 70% by weight in the case of glass fiber.
3. This process is used for making large products like storage tanks up to 15 or 16 m diameter by using special winding machines.
4. It is possible to vary the strength of the wound product in different directions by varying the angle of winding.

Limitations

1. Products with complicated profiles and reverse curvature cannot be wound.
2. The inter-laminar shear strength of the product is low.

3. The ultimate bearing strength is low. They are rigid but less ductile.
4. The laminate quality of the filament wound product is generally lower than that of the product made by autoclave processing.

MATERIALS

Reinforcement Fibers

Glass fiber is the common reinforcement fiber for commercial applications like chemical tanks, petroleum tanks, pipe lines etc. Aramid fibers including Kevlar 49, 29, and 149 are used for making products such as aerospace structures, rocket motor casing etc. Kevlar fibers have poor compressive and shear strength and are not usable for high temperature since they melt at 140°C. Carbon is the next versatile fiber because of their high modulus, strength and temperature resistance. Natural fibers provide good strength for applications like boats and silos by winding process but further research is needed to improve their durability.

Thermoset Resins

Polyester, vinylester, and epoxies are commonly used as thermosets. Polyester including isophthalic and bisphenol resins are used for chemical plants, petroleum tank and pipeline applications. Epoxies, because of their superior shear strength and mechanical and electrical properties used for high performance applications like aerospace and electrical insulation products. Vinylester finds applications in chemical resistant product. Polyimide, silicones, phenolics and furan resins finds applications in very special requirements like high temperature resistances.

Thermosets are used in wet winding, prepregs and wet rerolled rovings. Wet rerolled rovings are rovings impregnated with resin and rolled in to spool form and stored under low temperature and then unwound and used for winding.

Thermoplastic Resins

These resins are used to make prepregs by coating the thermoplastics on the fiber by melt dip coating, fiber transfer or by powder coating. The fiber reinforced thermoplastic prepreg tapes

are then wound using a tape winding machine. After winding the product can be heated to a level at which the resin melts and fuses into a solid.

WINDING FACILITY

Mandrels

The mandrel constitutes the important part of the winding setup. It is the tool around which the matrix impregnated rovings are wound. The profile of the mandrel gives the profile of the filament wound product. The mandrel must be smooth and easily removable after the product is fully cured.

Mandrels are broadly classified into (i) open ended non-collapsible mandrels and (ii) collapsible mandrels.

Open ended non-collapsible mandrels:

They are generally made of steel with smooth surface finishes and an axial taper of 1:200 for easy release of the product from mould. Screw and hydraulic extractors are used for the release of the product.

Collapsible mandrels:

a. Segmented metallic collapsible mandrels

The mandrel is made of several segments. The segments are dismantled to release the product.

b. Water soluble mandrels

Water soluble mandrels are made by casting over a centered axis and polar fittings, sand and water soluble polyvinyl alcohol.

c. Spider plastic mandrels

Plaster of Paris layer is made over removable or collapsible tooling. Plaster can be finished with either duco putty or with release films. After winding central mandrel is removed and the plaster is chopped off.

d. Inflatable mandrel

Mandrel is made by inflating a bag. They also present the problem of larger transmission.

e. Low melting alloy mandrels

Low melting alloys and metals like lead can be used for making the mandrel. Later, the mandrel material cannot be recovered.

f. Non-removable liners

Liners can be made from metals or plastics or FRP for liquid resistant surfaces.

WINDING MACHINES

The winding machine has facilities for wetting the fiber, tensioning the filament, laying the fiber or tapes in the required angle in a uniformly spreaded pattern. Winding machines can be broadly divided into three groups.

- a. Helical winding machines
- b. Polar winding machines
- c. Special purpose and advance winding machines

a. Helical winding machine

The helical winding machine is designed to lay the fiber on a rotating mandrel at winding angles varying from 0° (axial) to 90° (hoop) with axis of rotation. The basic movement of the helical winder is the mandrel rotation and the feed traverse. By varying the speed of two movements, it is possible to vary the winding angle. The feed eye moves to and fro from one end to other end creating an angle ply or netting structure on the mandrel surface.

The fiber is fed to the feed eye through a resin bath in the wet winding process. The resin bath also moves along with the feed eye. In case of prepreg winding the fibers or tapes are fed from a spool or creed stand. The creed stand is stationary or it is fixed with the resin carriage so that the stand also moves along with the feed eye. Fig.2.8 shows the layout of a typical helical winding machine.

Helical winding machines can be made with constant helix angles in which fibers can be wound only at constant angle with the axis or variable angle machines where the angle of winding can be varied from 0° to 90° with the axis. The variation is achieved by varying the mandrel surface speed and the feed point speed. Accurate speed variations can be possible by using numerically controlled step motors with or without servo hydraulic pulse motors. These machines have the advantage that winding angle can be changed along the length by pre-programmed using punched tapes or by using computers.

b. Polar winding machine

Polar winding is done generally for spherical, ellipsoidal or other closed axis symmetric shells. The two ends of the mandrel is called poles. The winding is done from one pole to the other. Fig.4.9 shows a typical polar winding machine.

The polar winding machine can be made in two different ways

1. The feeding eye is rotating while the mandrel is on a fixed axis with only rotating motion. This system needs the resin bath and fiber spool to travel with the feed eye.
2. The feeding eye is fixed while the mandrel has two motions with rotation about its axis and a rotation about one of the mounting supports. The advantage in this is the resin bath need not travel around the mandrel, but the rotation of heavy mandrel has to be done using a cantilever arrangement and the support system must be rigid enough to carry the load without causing any deflections.

Depending upon the way mandrel is supported, the winding machines can be classified into cantilever type or with both ends supported. In the cantilever type, the mandrel is supported at one end and the other end is free which helps to take round the mandrel without any obstruction.

c. Combined polar and helical winding machine:

Products like pressure vessels, road tankers, petroleum tanks etc. require a cylindrical shell with end domes having spherical, ellipsoidal shapes. One way is to make them separately and joined them together, which gives a weak joint at the junction. The better way is winding the shell and domed ends using combined helical and polar winding machines.

d. Special purpose machines:

Several other variations of filament winding machines have been developed for specific end uses and a few machines are described below.

1. Fixed mandrel machines:

For winding very large cylindrical tanks, rotating the mandrel for winding becomes very costly. In such cases the mandrel is kept stationary on a vertical axis. The resin bath together with fiber creels move around the mandrel and up and down to create the helical path around the mandrel

2. Race track machines:

In these machines the resin bath and fiber creel travels on a race track and the mandrel rotates about its axis. The winding angle is achieved by tilting the mandrel to the required positions.

3. Continuous pipe making machines:

These machines have stationary mandrels. The fiber spools are mounted on a circular ring which rotates around the mandrel. Two such rings rotating in the opposite direction create the helical or angle ply pattern on the mandrel. By controlling the linear and rotary motions of the ring the required winding angle can be obtained.

4. Braiding machine:

It is similar to the continuous filament winding except that the fibers get knitted during the winding process. Braiding without resin is used for fiber insulation of electrically conductive wires. Braiding with resin is used for making filament wound high pressure hoses.

Resin Curing System

In normal machines, the mandrel with wet wound shell is transferred to an oven where it is cured as per the cure schedule. In order to prevent the resin dripping, the mandrel is rotated slowly in the chamber until the resin gels. The rotation must be slow to prevent the resin coming to surface due to the centrifugal force. After curing the product is removed and then post cured if necessary.

Another way to cure is to use infrared rays which will be focused on to the wet wound shell. As the mandrel rotates slowly, the radiated heat helps to cure the resin.

For cold curing system, the cure can be achieved by keeping the mandrel rotated slowly until the resin gels. After curing the product will be released and it is post cured if necessary.

For large products, curing the product in oven is expensive. Hence, such products can be post cured using hot air circulation, local heating etc.

Mandrel extraction facility:

The extraction of the mandrel from the product is a difficult task in many cases particularly when the product is very large in size and also when the resin has a high cure shrinkage. The mandrel extraction can be done by different ways.

1. A hydraulic extractor can be used to pull out the mandrel.
2. The mandrel can be dismantled into pieces and pulled out through the side opening.
3. Dissolving of mandrel.

(vii) Spray-up molding:

Spray-up molding is an open mold method (Fig.2.8) that can produce complex parts more economically than hand lay-up. Chopped fiberglass reinforcement and catalyzed resin, and in some cases, filler materials, are deposited on the mold surface from a combination chopper/spray gun.

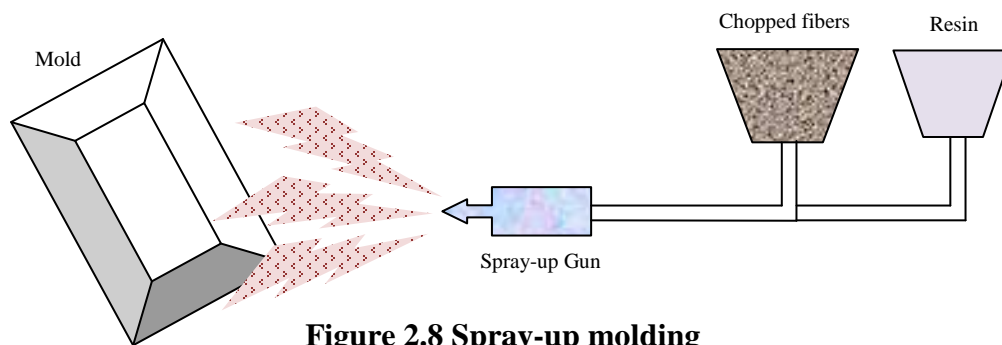

Figure 2.8 Spray-up molding

Rollers or squeegees are used to manually remove entrapped air and work the resin into the reinforcements. Woven fabric or woven roving is often added in specific areas for greater strength. As in hand lay-up, gel coats are used to produce a high quality colored part surface.

(viii) Vacuum Bag Molding:

Vacuum impregnation is a process in which the resin to fiber wetting is assisted by a vacuum. The main purpose of vacuum process is it removes the air which is trapped inside the laminate thus reducing the defect and improving the strength of the laminate.

Advantages of vacuum impregnation method:

- Improves the strength of the laminates by reducing the defects.
- Low cost when compared with compression mould laminates.
- Density of laminate is considerably lower than that of compression mould laminates.

Materials:**Reinforcements:**

All types of fiber reinforcements can be impregnated with resin using vacuum method.

Effects of vacuum method on reinforcements:

- Good formability.
- High strength.
- Good surface quality
- Wear resistance.
- High complex forms.

Resins:

The curing procedure of the resin, initial viscosity, the gelation time, and wettability, are the important properties to be considered for processing. For vacuum impregnation purpose the volatile content should be as low as possible. Both polyester and epoxy resins are used.

Factors to be considered for resins in vacuum method:

- Long pot life
- Less viscosity (11 Pa.s or 100 CP or less)
- Short gel time (less than 1 hour)

Mold Releasing Agents:

Releasing agents used include backed on Teflon (PTFE) or PVA coatings on the mould parts. For vacuum bag systems PTFE films which are porous are used along with conventional materials.

Adaptation of vacuum impregnation method:

Vacuum impregnation process is used in many related FRP fabrication processes such as:

- Vacuum impregnation
- Vacuum injection moulding
- Vacuum bag moulding

Vacuum impregnation:

Vacuum impregnation is used for the manufacture of products which need precisely controlled mechanical properties, thermal and electrical stability and good dimensional control.

(Fig 2.9a) Mould surface is treated with releasing agent. Reinforcements are then placed inside the mould. While closing the mould, care has to be taken to see whether it is completely sealed. Otherwise, when vacuum is applied to the mould, full vacuum may not be generated in the mould cavities.

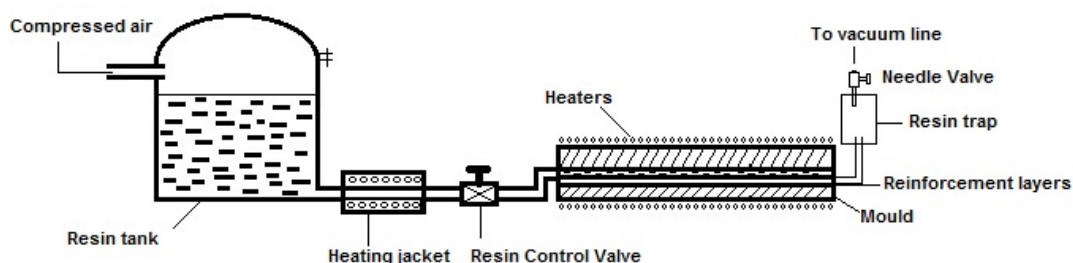

Figure 2.9a Vacuum impregnation

Vacuum is applied so that the resin gradually fills up the mould cavity and wets the reinforcements. Once the resin is completely filled in, the heating can be applied to accelerate the gelation and curing of the resin. After cure, the mould is declamped and the product is taken out.

Vacuum injection moulding:

It is a process where combination of vacuum impregnation and resin injection system are adapted. It is also known as Hoechst process. Moulds for this process can be made of GRP, lower half is of a rigid construction while the upper half is more flexible. A vacuum channel is built into the mould around the periphery for mould closure.

As usual the mould surfaces are waxed, polished and coated with PVA release agent. The reinforcements are cut to shape and fitted in the lower half of the mould. Once the upper half in position, vacuum is applied on the gasket channel sealing the mould and renders it air tight.

Catalyzed resin is injected under pressure. The air remaining in the mould is sucked out, while the flexible top half forces the resin to flow through the reinforcements until the mat is thoroughly impregnated and compacted.

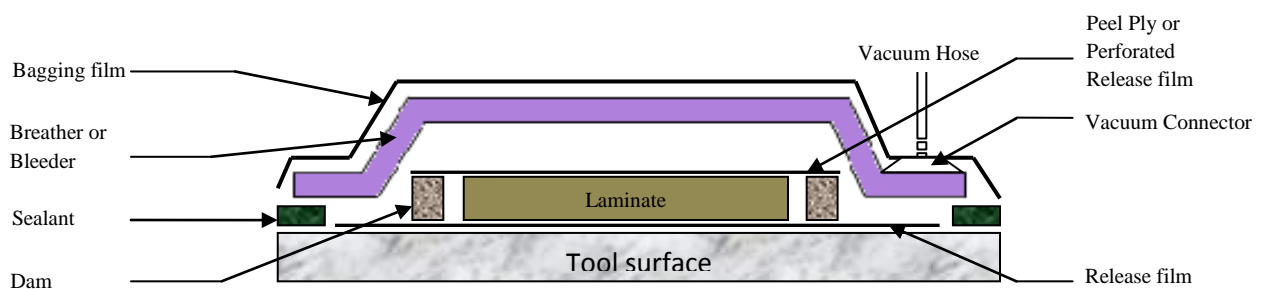

Figure 2.9b Vacuum Bag method

The lay-up is placed in the mould with separator on top of it usually made of Teflon coated glass. The bleeder is placed to absorb the excess resin from the lay-up, thus controlling the amount content during the curing process. Pressure plates are introduced to supply additional compression to the lay-up. Barrier film is used to control the resin flow in the bleeder.

Fig.2.9b Breather film is given beneath the vacuum bag to allow the uniform application of vacuum all over the area of the laminate and removal of excess air or volatiles developed during the cure.

Vacuum bag is used to contain the vacuum generated by the pump and applied to the lay-up. The application of vacuum bag is very critical. Bag porosity or punctures can result in a porous product. Complex tools may require the bag to be folded in places and thus require excess bag material. If the folds are not properly made or placed, wrinkles may be developed in the parts. The vacuum may be maintained till the resin gels.

(ix) Pressure Bag Molding

Pressure bag molding is similar to the vacuum bag molding method except that air

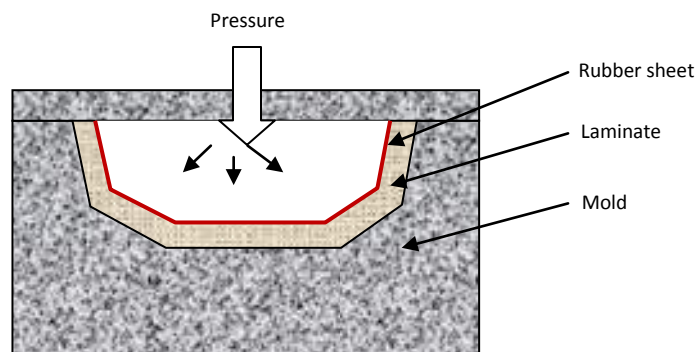

Figure 2.10 Pressure bag molding

pressure, usually 200 to 350 kPa, is applied to a rubber bag, or sheet that covers the laid up composite to force out entrapped air and excess resin (from Fig.2.10). Pressurized steam may be used instead, to accelerate the cure. Cores and inserts can be used with the process, and undercuts are practical, but only female and split molds can be used to make items such as tanks, containers, and wind turbine blades.

(x) Autoclave Molding

Autoclave molding is a modification of pressure-bag and vacuum-bag molding. This advanced composite process produces denser, void free moldings because higher heat and pressure

are used for curing. and resin, a nonadhering film of polyvinyl alcohol or nylon is placed over the lay-up and sealed at the mold flange. Autoclaves are essentially heated pressure vessels usually equipped with vacuum systems into which the bagged lay-up on the mold is taken for the cure cycle.

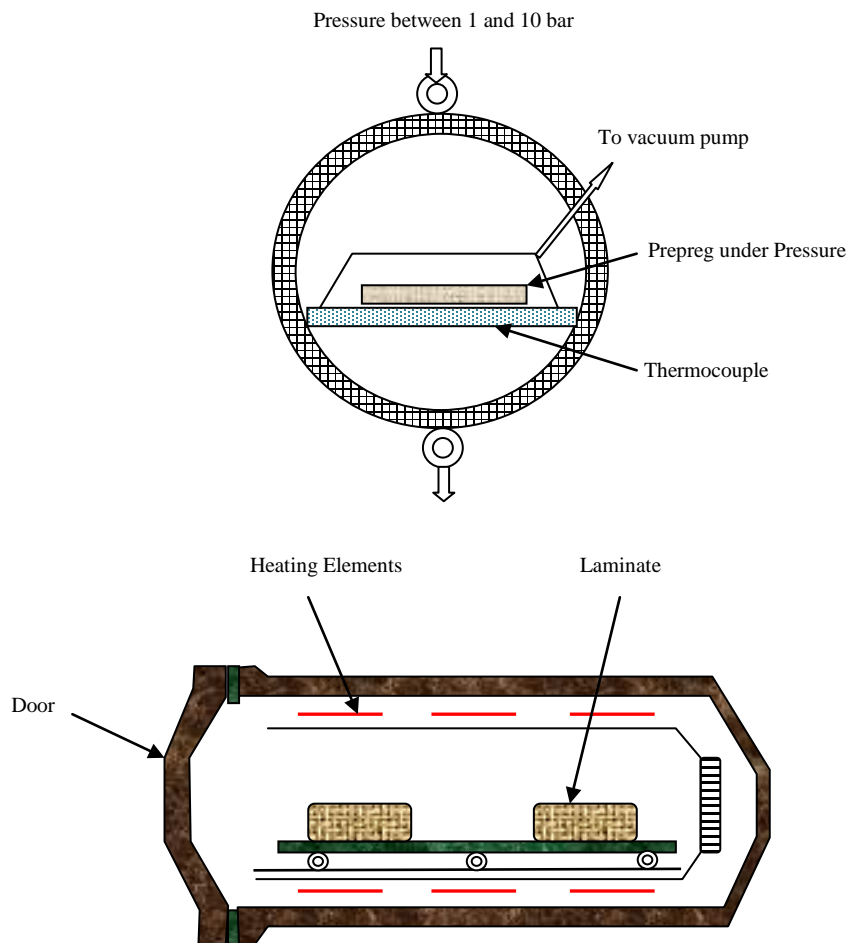

Figure 2.11 Autoclave molding

Curing pressures are generally in the range of 350 to 700 kPa and cure cycles normally involve many hours. The method accommodates higher temperature matrix resins such as epoxies, having higher properties than conventional resins.

Autoclave size limits part size. It is widely used in the aerospace industry to fabricate high strength/weight ratio parts from preimpregnated high strength fibers for aircraft, spacecraft and missiles. Many large primary structural components for aircraft, such as fins, wing spars and skins, fuselages and flying control surfaces, are manufactured by this method.

The starting material for autoclave moulding process is prepreg (Fig.2.11). A prepreg contains 42% weight of resin. If this prepreg is allowed to cure without any resin loss the cured laminate would contain 50% volume of fibers. Since, nearly 10% weight of resin flows out during the moulding process, the actual volume of fiber in the cured laminate is 60%.

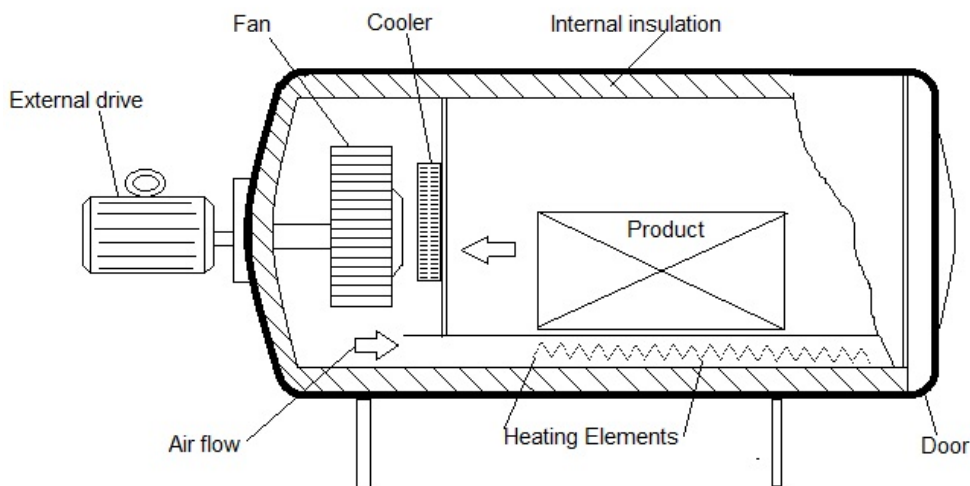

Figure 2.11a Autoclave Setup

After layup, a porous release cloth and a few layers of bleeder papers are placed on top of the prepreg stack. The bleeder paper is used to absorb the excess resin in the moulding process. The complete layup is covered with another Teflon sheet and then a thin heat resistant vacuum bag. The entire assembly is kept inside a preheated autoclave where a combination of pressure and temperature is applied and the plies are converted into a solid laminate.

As the prepreg is heated in the autoclave, the resin viscosity in the B-stage prepreg decreases up to its minimum and then increases rapidly as the curing reaction begins.

Cure cycle of an epoxy prepreg consists of two stages:

The first stage consists of increasing the temperature up to 130°C and dwelling at this temperature for 60 min. When the minimum viscosity reaches external pressure is applied to flow out the excess resin into the bleeder papers. This will remove the air entrapment and volatile from the prepreg.

At the end of temperature dwell, the autoclave temperature resets to the actual curing temperature of the resin. The cure temperature and the pressure is maintained for 2 hours or complete cure takes place. At the end of the cure cycle, the temperature is slowly reduced while the laminate is still under pressure. Finally, the laminate is removed from the bag and post cured if needed.

Equipment

The following data have to be specified for autoclave:

1. Maximum operating temperature
2. Rate of temperature rise
3. Rate of temperature decrease
4. Temperature control stability
5. Stabilized temperature uniformity
6. Maximum pressure
7. Pressurizing medium
8. Pressurization
9. Depressurization
10. Number of vacuum stations

11. Maximum exterior surface temperature
12. Workspace size
13. Heating
14. Cooling

Bagging materials, release sheets, peel plies and breather cloths

Bagging: Applying an impermeable layer of thin film over an uncured part and sealing edges so that a vacuum can be drawn.

Bagging film sealant tape: This is a soft mastic type of tape which is slightly tacky and is used to seal bagging film.

Breather cloth: A loosely woven material such as a glass fabric that will serve as a continuous vacuum path but not direct contact with the part. Its purpose is to allow removal of air, thereby applying atmospheric pressure to the part.

Bleeder cloth: A non-structural layer of material, used to allow the escape of gas and excess resin during the cure. The bleeder cloth is removed after the curing.

Peel ply: A layer of open-weave material, applied directly to the surface of a prepreg layup. Peel ply is removed from the cured laminate.

Release film: A material of thin film, used to keep the resin from bonding to the mould. Release films are made from non stick materials such as polyvinyl fluoride (PVF), fluorinated ethylene propylene (FEP), polyester and nylon.

Other techniques

There are few techniques which are recently developed for making composite products, This includes :

- Tube rolling
- Elastic reservoir molding
- Resin film infusion
- Reaction Injection Molding (RIM)
- Structural reaction injection molding

References:

1. Analysis and Performance of Fibre Composites – B.D. Agarwal, L.J. Broughtman and K. Chandrashekar, John Wiley & Sons. Inc.
2. Principles of Composite Material Mechanics, R.F. Gibson, CRC Press.
3. Prepregs and AutoClave Moulding, Dr. S.K. Malhotra, Comptec, Course Module, IIT Madras.
4. Vacuum Impregnation Methods, Dr. B.J.C. Babu, Comptec, Course Module, IIT Madras.
5. Resin Transfer Moulding, N.G. Nair Comptec, Course Module, IIT Madras.
6. Filament Moulding of FRP, N.G. Nair, Comptec, Course Module, IIT Madras.
7. Hand layup for FRP Fabrication, N.G. Nair, Course Module, IIT Madras.